



CYPRESS

PRELIMINARY

W48S101-04

Spread Spectrum Motherboard Frequency Generator

Features

- Maximized EMI suppression using Cypress's Spread Spectrum technology
- I²C™ interface
- Four copies of CPU output
- Eight copies of PCI clock (synchronous w/CPU output)
- Two copies of 14.318-MHz IOAPIC output
- One copy of 48-MHz USB output
- Selectable 24-/48-MHz clock-through-resistor strapping
- Three buffered copies of 14.318-MHz reference input
- Input is a 14.318-MHz XTAL or reference signal
- Selectable 100-MHz or 66-MHz CPU outputs
- Power management control input pins
- Test mode and output three-state through I²C interface

Key Specifications

Supply Voltages:..... V_{DDQ3} = 3.3V±5%
 V_{DDQ2} = 2.5V±5%

CPU Cycle to Cycle Jitter:..... 200 ps

CPU0:3 Output Skew: 175 ps

PCI_F, PCI1:7 Output Skew: 500 ps

CPU to PCI Output Skew: 1.5 to 4.0 ns (CPU Leads)

Logic inputs and REF0/SEL48# have 250K pull-up resistors except SEL100/66#.

Table 1. Pin Selectable Frequency

SEL 100/66#	CPU (MHz)	PCI (MHz)	SPREAD#=0
0	66.8	33.4	±0.5% Center
1	100	33.3	±0.5% Center

Block Diagram

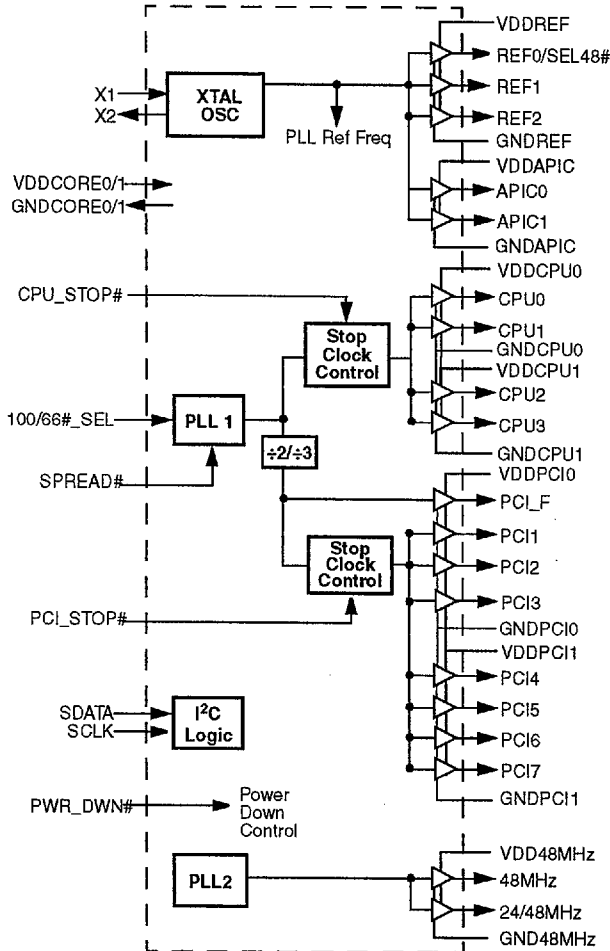

Pin Configuration^[1]

REF0/SEL48#	1	48	VDDREF
REF1	2	47	REF2
GNDREF	3	46	VDDAPIC
X1	4	45	APIC0
X2	5	44	APIC1
GNDPCI0	6	43	GNDAPIC
PCICLK_F	7	42	NC
PCI1	8	41	VDDCPU0
VDDPCI0	9	40	CPU0
PCI2	10	39	CPU1
PCI3	11	38	GNDCPU0
GNDPCI1	12	37	VDDCPU1
PCI4	13	36	CPUCLK2
PCI5	14	35	CPUCLK3
VDDPCI1	15	34	GNDCPU1
PCI6	16	33	VDDCORE1
PCI7	17	32	GNDCORE1
GNDPCI2	18	31	PCI_STOP#
VDDCORE0	19	30	CPU_STOP#
GNDCORE0	20	29	PWR_DWN#
VDD48MHz	21	28	SPREAD#
48MHz	22	27	SDATA
24/48MHz	23	26	SCLK
GND48MHz	24	25	SEL100/66#

Note:

1. Internal pull-up resistors should not be relied upon for setting I/O pins HIGH.

¹C is a trademark of Philips Corporation.

Pin Definitions

Pin Name	Pin No.	Pin Type	Pin Description
CPU0:3	40, 39, 36, 35	O	CPU Clock Outputs 0 through 3: These four CPU clock outputs are controlled by the CPU_STOP# control pin. Output voltage swing is controlled by voltage applied to VDDQ2.
PCI1:7	8, 10, 11, 13, 14, 16, 17	O	PCI Bus Clock Outputs 1 through 7: These seven PCI clock outputs are controlled by the PCI_STOP# control pin. Output voltage swing is controlled by voltage applied to VDDQ3.
PCI_F	7	O	Fixed PCI Clock Output: Unlike PCI1:7 outputs, this output is not controlled by the PCI_STOP# control pin. Output voltage swing is controlled by voltage applied to VDDQ3.
CPU_STOP#	30	I	CPU_STOP# Input: When brought LOW, clock outputs CPU0:3 are stopped LOW after completing a full clock cycle (2–3 CPU clock latency). When brought HIGH, clock outputs CPU0:3 start beginning with a full clock cycle (2–3 CPU clock latency).
PCI_STOP#	31	I	PCI_STOP# Input: The PCI_STOP# input enables the PCI 1:7 outputs when HIGH and causes them to remain at logic 0 when LOW. The PCI_STOP signal is latched on the rising edge of PCI_F. Its effect takes place on the next PCI_F clock cycle.
SPREAD#	28	I	SPREAD# Input: When brought LOW this pin activates Spread Spectrum clocking.
APIC0:1	45, 44	O	I/O APIC Clock Outputs: Provides 14.318-MHz fixed frequency. The output voltage swing is controlled by VDDQ2.
48MHz	22	O	48-MHz Output: Fixed clock outputs at 48 MHz. Output voltage swing is controlled by voltage applied to VDDQ3.
24/48MHz	23	O	24-MHz or 48-MHz Output: 24-MHz output when pin 1 is strapped through 10-kΩ resistor to VDDQ3. 48-MHz output when pin 1 is strapped through 10-kΩ resistor to GND.
REF0/SEL48#	1	I/O	I/O Dual Function REF0 and SEL48# pin: During power on, SEL48# input will be latched, which will set pin 23 to output 24 MHz or 48 MHz. It then reverts to REF0 fixed output.
REF1:2	2, 47	O	Fixed 14,318-MHz Outputs 1 through 2: Used for various system applications. Output voltage swing is controlled by voltage applied to VDDQ3.
SEL100/66#	25	I	Frequency Selection Input: Selects power-up default CPU clock frequency as shown in Table 1 on page 1.
SCLK	26	I	Clock pin for I ² C circuitry.
SDATA	27	I/O	Data pin for I ² C circuitry.
X1	4	I	Crystal Connection or External Reference Frequency Input: This pin has dual functions. It can be used as an external 14.318-MHz crystal connection or as an external reference frequency input.
X2	5	I	Crystal Connection: An input connection for an external 14.318-MHz crystal. If using an external reference, this pin must be left unconnected.
PWR_DWN#	29	I	Power Down Control: When this input is LOW, device goes into a low-power stand-by condition. All outputs are actively held LOW while in power-down. CPU and PCI clock outputs are stopped LOW after completing a full clock cycle (2–3 CPU clock cycle latency). When brought HIGH, CPU, SDRAM and PCI outputs start with a full clock cycle at full operating frequency (3 ms maximum latency).
VDDQ3	9, 15, 19, 21, 33, 48	P	Power Connection: Connect to 3.3V supply.
VDDQ2	46, 41, 37	P	Power Connection: Power supply for APIC0:1 and CPU0:3 output buffers. Connect to 2.5V.
GND	3, 6, 12, 18, 20, 24, 32, 34, 38, 43	G	Ground Connections: Connect all ground pins to the common system ground plane.

Overview

The W48S101-04, a motherboard clock synthesizer, can provide either a 2.5V or 3.3V CPU clock swing, making it suitable for a variety of CPU options. A fixed 48-MHz clock is provided for other system functions. The W48S101-04 supports spread spectrum clocking for reduced EMI.

Functional Description

I/O Pin Operation

Pin 1 is a dual-purpose I/O pin. Upon power-up this pin acts as a logic input, allowing the determination of assigned device functions. A short time after power-up, the logic state of the pin is latched and the pin becomes a clock output. This feature reduces device pin count by combining clock outputs with input select pins.

An external 10-k Ω "strapping" resistor is connected between the I/O pin and ground or V_{DD}. Connection to ground sets a latch to "0," connection to V_{DD} sets a latch to "1." Figure 1 and Figure 2 show two suggested methods for strapping resistor connections.

Upon W48S101-04 power-up, the first 2 ms of operation is used for input logic selection. During this period, the Reference clock output buffer is three-stated, allowing the output

strapping resistor on the I/O pin to pull the pin and its associated capacitive clock load to either a logic HIGH or LOW state. At the end of the 2-ms period, the established logic "0" or "1" condition of the I/O pin is then latched. Next the output buffer is enabled, which converts the I/O pin into an operating clock output. The 2-ms timer is started when V_{DD} reaches 2.0V. The input bit can only be reset by turning V_{DD} off and then back on again.

It should be noted that the strapping resistor has no significant effect on clock output signal integrity. The drive impedance of clock output is 40 Ω (nominal) which is minimally affected by the 10-k Ω strap to ground or V_{DD}. As with the series termination resistor, the output strapping resistor should be placed as close to the I/O pin as possible in order to keep the interconnecting trace short. The trace from the resistor to ground or V_{DD} should be kept less than two inches in length to prevent system noise coupling during input logic sampling.

When the clock output is enabled following the 2-ms input period, a 14.318-MHz output frequency is delivered on the pin, assuming that V_{DD} has stabilized. If V_{DD} has not yet reached full value, output frequency initially may be below target but will increase to target once V_{DD} voltage has stabilized. In either case, a short output clock cycle may be produced from the CPU clock outputs when the outputs are enabled.

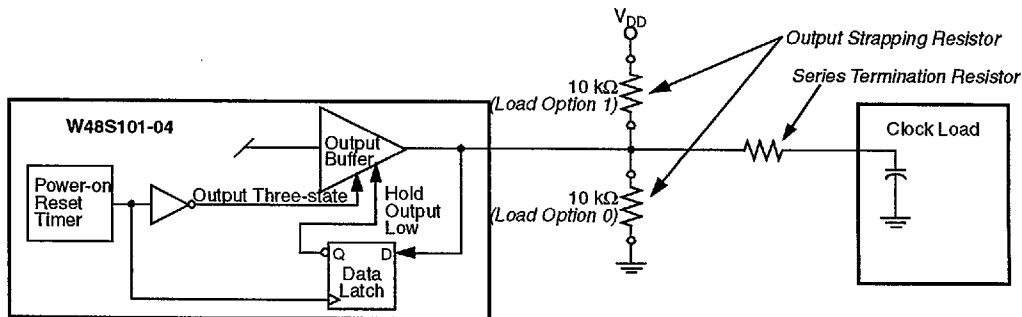

Figure 1. Input Logic Selection Through Resistor Load Option

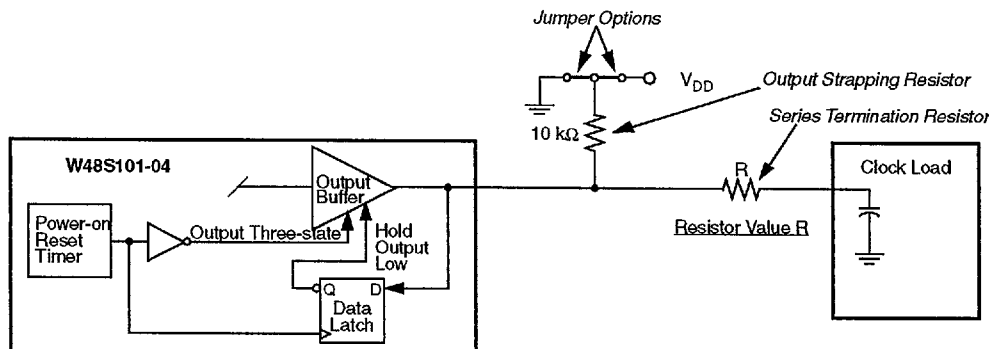

Figure 2. Input Logic Selection Through Jumper Option

Spread Spectrum Clock Generation

The benefits of using Spread Spectrum Clock Generation are depicted in *Figure 3*. An EMI emission profile of a clock harmonic is shown.

Contrast the typical clock EMI with the Cypress Spread Spectrum Clock Generation. Notice the spike in the typical clock. This spike can make systems fail quasi-peak EMI testing. The FCC and other regulatory agencies test for peak emissions. With the Cypress clock, the peak energy is much lower (at least 8 dB) because the energy is spread out across a wider bandwidth.

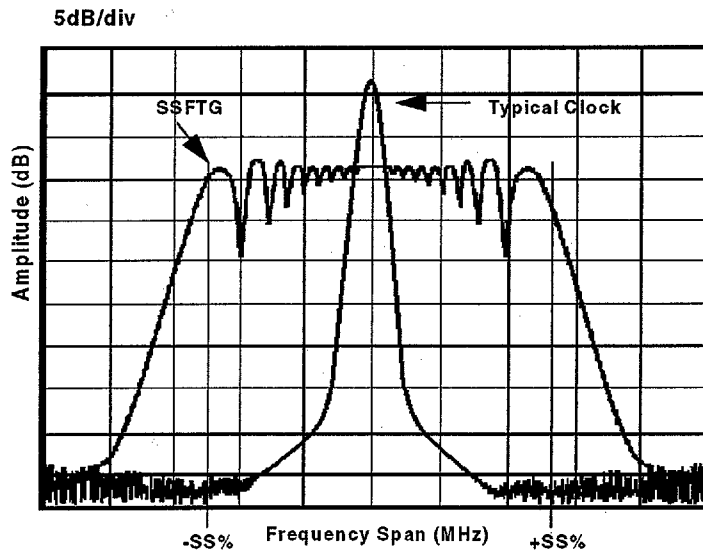

Figure 3. Typical Clock and SSCG Comparison

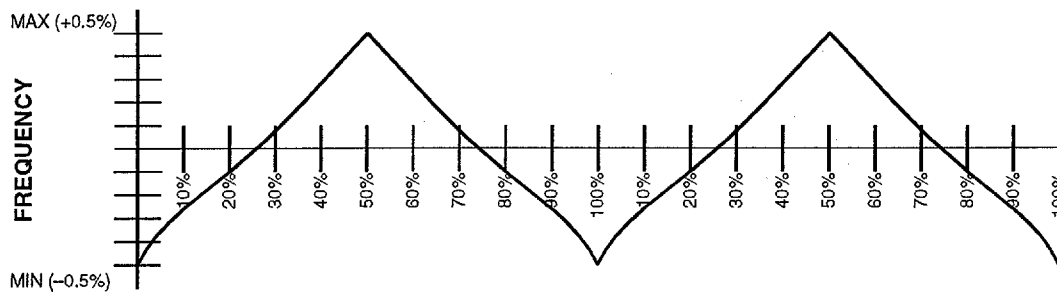

Figure 4. Typical Modulation Profile

Serial Data Interface

The W48S101-04 features a two-pin, serial data interface that can be used to configure internal register settings that control particular device functions. Upon power-up, the W48S101-04 initializes with default register settings. Therefore, the use of this serial data interface is optional. The serial interface is write-only (to the clock chip) and is the dedicated function of device pins SDATA and SCLOCK. In motherboard applications, SDATA and SCLOCK are typically driven by two logic

outputs of the chipset. Clock device register changes are normally made upon system initialization, if required. The interface can also be used during system operation for power management functions. *Table 2* summarizes the control functions of the serial data interface.

Operation

Data is written to the W48S101-04 in ten bytes of eight bits each. Bytes are written in the order shown in *Table 3*.

Table 2. Serial Data Interface Control Functions Summary

Control Function	Description	Common Application
Clock Output Disable	Any individual clock output(s) can be disabled. Disabled outputs are actively held LOW.	Unused outputs are disabled to reduce EMI and system power. Examples are clock outputs to unused PCI slots.
CPU Clock Frequency Selection	Provides CPU/PCI frequency selections beyond the 100- and 66.6-MHz selections that are provided by the SEL100/66# pin. Frequency is changed in a smooth and controlled fashion.	For alternate microprocessors and power management options. Smooth frequency transition allows CPU frequency change under normal system operation.
Output Three-state	Puts all clock outputs into a high-impedance state.	Production PCB testing.
Test Mode	All clock outputs toggle in relation to X1 input, internal PLL is bypassed. Refer to <i>Table 4</i> .	Production PCB testing.
(Reserved)	Reserved function for future device revision or production device testing.	No user application. Register bit must be written as 0.

Table 3. Byte Writing Sequence

Byte Sequence	Byte Name	Bit Sequence	Byte Description
1	Slave Address	11010010	Commands the W48S101-04 to accept the bits in Data Bytes 3–6 for internal register configuration. Since other devices may exist on the same common serial data bus, it is necessary to have a specific slave address for each potential receiver. The slave receiver address for the W48S101-04 is 11010010. Register setting will not be made if the Slave Address is not correct (or is for an alternate slave receiver).
2	Command Code	Don't Care	Unused by the W48S101-04, therefore bit values are ignored ("don't care"). This byte must be included in the data write sequence to maintain proper byte allocation. The Command Code Byte is part of the standard serial communication protocol and may be used when writing to another addressed slave receiver on the serial data bus.
3	Byte Count	Don't Care	Unused by the W48S101-04, therefore bit values are ignored ("don't care"). This byte must be included in the data write sequence to maintain proper byte allocation. The Byte Count Byte is part of the standard serial communication protocol and may be used when writing to another addressed slave receiver on the serial data bus.
4	Data Byte 0	Don't Care	Refer to Cypress SDRAM drivers.
5	Data Byte 1		
6	Data Byte 2		
7	Data Byte 3	Refer to <i>Table 4</i>	The data bits in these bytes set internal W48S101-04 registers that control device operation. The data bits are only accepted when the Address Byte bit sequence is 11010010, as noted above. For description of bit control functions, refer to <i>Table 4</i> , Data Byte Serial Configuration Map.
8	Data Byte 4		
9	Data Byte 5		
10	Data Byte 6		

Writing Data Bytes

Each bit in the data bytes controls a particular device function except for the “reserved” bits, which must be written as a logic 0. Bits are written MSB (most significant bit) first, which is bit 7. Table 4 gives the bit formats for registers located in Data Bytes 3–6.

Table 5 details additional frequency selections that are available through the serial data interface.

Table 6 details the select functions for Byte 3, bits 1 and 0.

Table 4. Data Bytes 3–6 Serial Configuration Map

Bit(s)	Affected Pin		Control Function	Bit Control		Default
	Pin No.	Pin Name		0	1	
Data Byte 3						
7	--	--	(Reserved)	--	--	0
6	--	--	SEL_2	Refer to Table 5		0
5	--	--	SEL_1	Refer to Table 5		0
4	--	--	SEL_0	Refer to Table 5		0
3	--	--	BYT0_FS#	Frequency Controlled by external SEL100/66# pin	Frequency Controlled by BYT0 SEL (2:0)	0
2	--	--	(Reserved)	--	--	0
1-0	--	--	Bit 1 Bit 0 Function (See Table 6 for function details) 0 0 Normal Operation 0 1 Test Mode 1 0 Spread Spectrum on (See Table 5 for frequency and spread selections. ±0.5% modulation) 1 1 All Outputs Three-stated			00
Data Byte 4						
7	--	--	(Reserved)	--	--	0
6	23	24/48MHz	Clock Output Disable	Low	Active	1
5	--	--	(Reserved)	--	--	0
4	--	--	(Reserved)	--	--	0
3	35	CPU3	Clock Output Disable	Low	Active	1
2	36	CPU2	Clock Output Disable	Low	Active	1
1	39	CPU1	Clock Output Disable	Low	Active	1
0	40	CPU0	Clock Output Disable	Low	Active	1
Data Byte 5						
7	7	PCICLK_F	Clock Output Disable	Low	Active	1
6	17	PCI7	Clock Output Disable	Low	Active	1
5	16	PCI6	Clock Output Disable	Low	Active	1
4	14	PCI5	Clock Output Disable	Low	Active	1
3	13	PCI4	Clock Output Disable	Low	Active	1
2	11	PCI3	Clock Output Disable	Low	Active	1
1	10	PCI2	Clock Output Disable	Low	Active	1
0	8	PCI1	Clock Output Disable	Low	Active	1
Data Byte 6						
7	--	--	(Reserved)	--	--	0
6	--	--	(Reserved)	--	--	0
5	44	IOAPIC1	Clock Output Disable	Low	Active	1
4	45	IOAPIC0	Clock Output Disable	Low	Active	1
3	--	--	(Reserved)	--	--	0
2	47	REF2	Clock Output Disable	Low	Active	1
1	2	REF1	Clock Output Disable	Low	Active	1
0	1	REF0	Clock Output Disable	Low	Active	1

Table 5. Additional Frequency Selections through Serial Data Interface Data Bytes

Input Conditions			Output Frequency		
Data Byte 3, Bit 3 = 1			CPU, SDRAM Clocks (MHz)	PCI Clocks (MHz)	Spread Percentage with Spread Spectrum turned on
Bit 6 SEL_2	Bit 5 SEL_1	Bit 4 SEL_0			
0	0	0	68.5	34.25	± 0.5% Center
0	0	1	75	37.5	± 0.5% Center
0	1	0	83.3	41.6	± 0.5% Center
0	1	1	66.8	33.4	± 0.5% Center
1	0	0	103	34.33	± 0.5% Center
1	0	1	112	37.33	± 0.5% Center
1	1	0	133.3	44.43	± 0.5% Center
1	1	1	100	33.3	± 0.5% Center

Table 6. Select Function for Data Byte 3, Bits 0:1

Function	Input Conditions		Output Conditions				
	Data Byte 3		CPU0:3	PCI_F, PCI1:7	REF0:2, IOAPIC0:1	48MHZ	24MHZ
	Bit 1	Bit 0					
Normal Operation	0	0	Note 2	Note 2	14.318 MHz	48 MHz	24 MHz
Test Mode	0	1	X1/2	CPU/2, 3, or 4	X1	X1/2	X1/4
Spread Spectrum On	1	0	Note 2, 55%±0.5	Note 2, 55%±0.5	14.318 MHz	48 MHz	24 MHz
Three-state	1	1	Hi-Z	Hi-Z	Hi-Z	Hi-Z	Hi-Z

Note:

 2. CPU and PCI frequency selections are listed in *Table 1* and *Table 5*.

Absolute Maximum Ratings

Stresses greater than those listed in this table may cause permanent damage to the device. These represent a stress rating only. Operation of the device at these or any other conditions

above those specified in the operating sections of this specification is not implied. Maximum conditions for extended periods may affect reliability.

Parameter	Description	Rating	Unit
V_{DD}, V_{IN}	Voltage on any pin with respect to GND	-0.5 to +7.0	V
T_{STG}	Storage Temperature	-65 to +150	°C
T_A	Operating Temperature	0 to +70	°C
T_B	Ambient Temperature under Bias	-55 to +125	°C
ESD_{PROT}	Input ESD Protection	2 (min.)	kV

DC Electrical Characteristics: $T_A = 0^{\circ}\text{C}$ to $+70^{\circ}\text{C}$, $V_{DDQ3} = 3.3\text{V} \pm 5\%$, $V_{DDQ2} = 2.5\text{V} \pm 5\%$

Parameter	Description	Test Condition	Min.	Typ.	Max.	Unit	
Supply Current							
I_{DDQ3}	3.3V Supply Current	CPUCLK = 100 MHz Outputs Loaded ^[3]			120	mA	
I_{DDQ3}	2.5V Supply Current				60	mA	
Logic Inputs							
V_{IL}	Input Low Voltage		GND - 0.3		0.8	V	
V_{IH}	Input High Voltage		2.0		$V_{DD} + 0.3$	V	
I_{IL}	Input Low Current ^[4]				-25	μA	
I_{IH}	Input High Current ^[4]				10	μA	
I_{IL}	Input Low Current (SEL100/66#)				-5	μA	
I_{IH}	Input High Current (SEL100/66#)				5	μA	
Clock Outputs							
V_{OL}	Output Low Voltage	$I_{OL} = 1\text{ mA}$			50	mV	
V_{OH}	Output High Voltage	$I_{OH} = -1\text{ mA}$	3.1			V	
V_{OH}	Output High Voltage (CPU, APIC)	$I_{OH} = -1\text{ mA}$	2.2			V	
I_{OL}	Output Low Current	CPU0:3	$V_{OL} = 1.25\text{V}$	27	57	97	mA
		PCI_F, PCI1:7	$V_{OL} = 1.5\text{V}$	20.5	53	139	mA
		APIC0:1	$V_{OL} = 1.25\text{V}$	40	85	140	mA
		REF0:2	$V_{OL} = 1.5\text{V}$	25	37	76	mA
		48MHz 0:1	$V_{OL} = 1.5\text{V}$	25	37	76	mA
I_{OH}	Output High Current	CPU0:3	$V_{OL} = 1.25\text{V}$	25	55	97	mA
		PCI_F, PCI1:7	$V_{OL} = 1.5\text{V}$	31	55	189	mA
		APIC0:1	$V_{OL} = 1.25\text{V}$	40	87	155	mA
		REF0:2	$V_{OL} = 1.5\text{V}$	27	44	94	mA
		48MHz 0:1	$V_{OL} = 1.5\text{V}$	27	44	94	mA

Notes:

- All clock outputs loaded with maximum lump capacitance test load specified in the AC Electrical Characteristics section.
- W48S101-04 logic inputs have internal pull-up devices, except SEL100/66#.

DC Electrical Characteristics: $T_A = 0^{\circ}\text{C}$ to $+70^{\circ}\text{C}$, $V_{DDQ3} = 3.3\text{V} \pm 5\%$, $V_{DDQ2} = 2.5\text{V} \pm 5\%$ (continued)

Parameter	Description	Test Condition	Min.	Typ.	Max.	Unit
Crystal Oscillator						
V_{TH}	X1 Input Threshold Voltage ^[5]			1.5		V
C_{LOAD}	Load Capacitance, as seen by External Crystal ^[6]			14		pF
$C_{IN,X1}$	X1 Input Capacitance ^[7]	Pin X2 unconnected		28		pF
Pin Capacitance/Inductance						
C_{IN}	Input Pin Capacitance	Except X1 and X2			5	pF
C_{OUT}	Output Pin Capacitance				6	pF
L_{IN}	Input Pin Inductance				7	nH

AC Electrical Characteristics

$T_A = 0^{\circ}\text{C}$ to $+70^{\circ}\text{C}$, $V_{DDQ3} = 3.3\text{V} \pm 5\%$, $V_{DDQ2} = 2.5\text{V} \pm 5\%$, $f_{XTL} = 14.31818\text{ MHz}$

AC clock parameters are tested and guaranteed over stated operating conditions using the stated lump capacitive load at the clock output; Spread Spectrum clocking is disabled.

CPU Clock Outputs, CPU0:3 (Lump Capacitance Test Load = 20 pF)

Parameter	Description	Test Condition/Comments	CPU = 66.8 MHz			CPU = 100 MHz			Unit
			Min.	Typ.	Max.	Min.	Typ.	Max.	
t_P	Period	Measured on rising edge at 1.25V	15		15.5	10		10.5	ns
t_H	High Time	Duration of clock cycle above 2.0V	5.2			3.0			ns
t_L	Low Time	Duration of clock cycle below 0.4V	5.0			2.8			ns
t_R	Output Rise Edge Rate	Measured from 0.4V to 2.0V	1		4	1		4	V/ns
t_F	Output Fall Edge Rate	Measured from 2.0V to 0.4V	1		4	1		4	V/ns
t_D	Duty Cycle	Measured on rising and falling edge at 1.25V	45		55	45		55	%
t_{JC}	Jitter, Cycle-to-Cycle	Measured on rising edge at 1.25V. Maximum difference of cycle time between two adjacent cycles.			200			250	ps
t_{SK}	Output Skew	Measured on rising edge at 1.25V			175			175	ps
t_{ST}	Frequency Stabilization from Power-up (cold start)	Assumes full supply voltage reached within 1 ms from power-up. Short cycles exist prior to frequency stabilization.			3			3	ms
Z_o	AC Output Impedance	Average value during switching transition. Used for determining series termination value.		20			20		Ω

Notes:

5. X1 input threshold voltage (typical) is $V_{DD}/2$.
6. The W48S101-04 contains an internal crystal load capacitor between pin X1 and ground and another between pin X2 and ground. Total load placed on crystal is 14 pF; this includes typical stray capacitance of short PCB traces to crystal.
7. X1 input capacitance is applicable when driving X1 with an external clock source (X2 is left unconnected).

PCI Clock Outputs, PCI1:7 and PCI_F (Lump Capacitance Test Load = 30 pF)

Parameter	Description	Test Condition/Comments	CPU = 66.8/100 MHz			Unit
			Min.	Typ.	Max.	
t _p	Period	Measured on rising edge at 1.5V	30			ns
t _H	High Time	Duration of clock cycle above 2.4V	12			ns
t _L	Low Time	Duration of clock cycle below 0.4V	12			ns
t _R	Output Rise Edge Rate	Measured from 0.4V to 2.4V	1		4	V/ns
t _F	Output Fall Edge Rate	Measured from 2.4V to 0.4V	1		4	V/ns
t _D	Duty Cycle	Measured on rising and falling edge at 1.5V	45		55	%
t _{JC}	Jitter, Cycle-to-Cycle	Measured on rising edge at 1.5V. Maximum difference of cycle time between two adjacent cycles.			250	ps
t _{SK}	Output Skew	Measured on rising edge at 1.5V			500	ps
t _O	CPU to PCI Clock Skew	Covers all CPU/PCI outputs. Measured on rising edge at 1.5V. CPU leads PCI output.	1.5		4	ns
f _{ST}	Frequency Stabilization from Power-up (cold start)	Assumes full supply voltage reached within 1 ms from power-up. Short cycles exist prior to frequency stabilization.			3	ms
Z _O	AC Output Impedance	Average value during switching transition. Used for determining series termination value.		30		Ω

APIC0:1 Clock Output (Lump Capacitance Test Load = 20 pF)

Parameter	Description	Test Condition/Comments	CPU = 66.8/100 MHz			Unit
			Min.	Typ.	Max.	
f	Frequency, Actual	Frequency generated by crystal oscillator	14.31818			MHz
t _R	Output Rise Edge Rate	Measured from 0.4V to 2.0V	1		4	V/ns
t _F	Output Fall Edge Rate	Measured from 2.0V to 0.4V	1		4	V/ns
t _D	Duty Cycle	Measured on rising and falling edge at 1.25V	45		55	%
f _{ST}	Frequency Stabilization from Power-up (cold start)	Assumes full supply voltage reached within 1 ms from power-up. Short cycles exist prior to frequency stabilization.			1.5	ms
Z _O	AC Output Impedance	Average value during switching transition. Used for determining series termination value.		15		Ω

REF0:2 Clock Output (Lump Capacitance Test Load = 20 pF)

Parameter	Description	Test Condition/Comments	CPU = 66.8/100 MHz			Unit
			Min.	Typ.	Max.	
f	Frequency, Actual	Frequency generated by crystal oscillator	14.318			MHz
t _R	Output Rise Edge Rate	Measured from 0.4V to 2.4V	0.5		2	V/ns
t _F	Output Fall Edge Rate	Measured from 2.4V to 0.4V	0.5		2	V/ns
t _D	Duty Cycle	Measured on rising and falling edge at 1.5V	45		55	%
f _{ST}	Frequency Stabilization from Power-up (cold start)	Assumes full supply voltage reached within 1 ms from power-up. Short cycles exist prior to frequency stabilization.			3	ms
Z _O	AC Output Impedance	Average value during switching transition. Used for determining series termination value.		40		Ω



48MHz0:1 Clock Output (Lump Capacitance Test Load = 20 pF = 66.6/100 MHz)

Parameter	Description	Test Condition/Comments	CPU = 66.8/100 MHz			Unit
			Min.	Typ.	Max.	
f	Frequency, Actual	Determined by PLL divider ratio (see m/n below)	48.008			MHz
f _D	Deviation from 48 MHz	(48.008 - 48)/48	+167			ppm
m/n	PLL Ratio	(14.31818 MHz x 57/17 = 48.008 MHz)	57/17			
t _R	Output Rise Edge Rate	Measured from 0.4V to 2.4V	0.5		2	V/ns
t _F	Output Fall Edge Rate	Measured from 2.4V to 0.4V	0.5		2	V/ns
t _D	Duty Cycle	Measured on rising and falling edge at 1.5V	45		55	%
f _{ST}	Frequency Stabilization from Power-up (cold start)	Assumes full supply voltage reached within 1 ms from power-up. Short cycles exist prior to frequency stabilization.			3	ms
Z _o	AC Output Impedance	Average value during switching transition. Used for determining series termination value.		40		Ω

Ordering Information

Ordering Code	Freq. Mask Code	Package Name	Package Type
W48S101	-04	H	48-pin SSOP (300 mils)

Document #: 38-00853

Package Diagram

48-Pin Small Shrink Outline Package (SSOP, 300 mils)

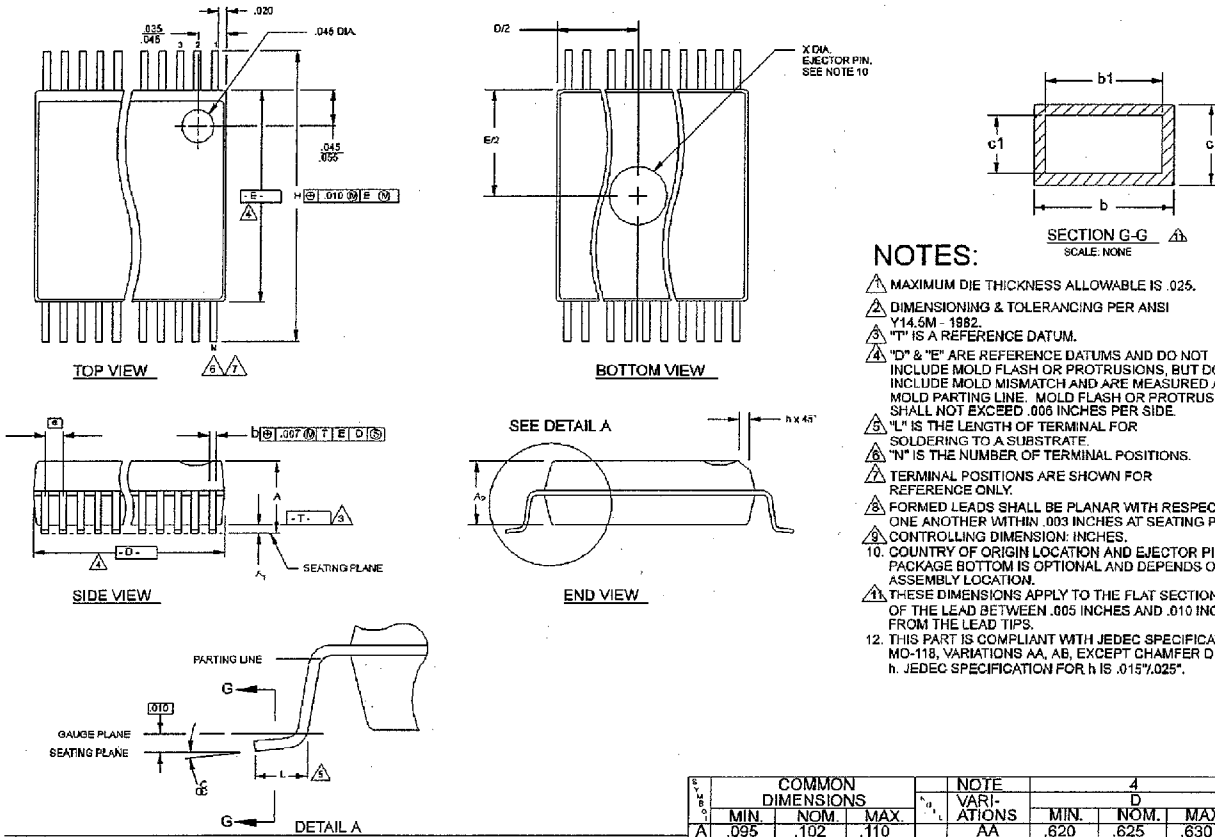

NOTES:

- ▲ MAXIMUM DIE THICKNESS ALLOWABLE IS .025.
- ▲ DIMENSIONING & TOLERANCING PER ANSI Y14.5M - 1982.
- ▲ "T" IS A REFERENCE DATUM.
- ▲ "D" & "E" ARE REFERENCE DATUMS AND DO NOT INCLUDE MOLD FLASH OR PROTRUSIONS, BUT DOES INCLUDE MOLD MISMATCH AND ARE MEASURED AT THE MOLD PARTING LINE. MOLD FLASH OR PROTRUSIONS SHALL NOT EXCEED .006 INCHES PER SIDE.
- ▲ "L" IS THE LENGTH OF TERMINAL FOR SOLDERING TO A SUBSTRATE.
- ▲ "N" IS THE NUMBER OF TERMINAL POSITIONS.
- ▲ TERMINAL POSITIONS ARE SHOWN FOR REFERENCE ONLY.
- ▲ FORMED LEADS SHALL BE PLANAR WITH RESPECT TO ONE ANOTHER WITHIN .003 INCHES AT SEATING PLANE.
- ▲ CONTROLLING DIMENSION: INCHES.
- 10. COUNTRY OF ORIGIN LOCATION AND EJECTOR PIN ON PACKAGE BOTTOM IS OPTIONAL AND DEPENDS ON ASSEMBLY LOCATION.
- ▲ THESE DIMENSIONS APPLY TO THE FLAT SECTION OF THE LEAD BETWEEN .005 INCHES AND .010 INCHES FROM THE LEAD TIPS.
- 12. THIS PART IS COMPLIANT WITH JEDEC SPECIFICATION MO-118, VARIATIONS AA, AB, EXCEPT CHAMFER DIMENSION h. JEDEC SPECIFICATION FOR h IS .015"(.025)".

Summary of nominal dimensions in inches:

Body Width: 0.296
 Lead Pitch: 0.025
 Body Length: 0.625
 Body Height: 0.102

DIM.	COMMON DIMENSIONS			NOTE VARIATIONS	4 D			6 N
	MIN.	NOM.	MAX.		MIN.	NOM.	MAX.	
A	.095	.102	.110	AA	.620	.625	.630	48
A ₁	.008	.012	.016	AB	.720	.725	.730	56
A ₂	.088	.090	.092					
b	.008	.010	.0135					
b ₁	.008	.010	.012					
c	.005	-	.010					
c ₁	.005	.006	.0085					
D	SEE VARIATIONS			4				
E	.292	.298	.299					
e	.025 BSC							
H	.400	.406	.410					
h	.010	.013	.016					
L	.024	.032	.040					
N	SEE VARIATIONS			6				
X	.085	.093	.100	10				
d ₁	0°	5°	8°					

THIS TABLE IN INCHES

DIM.	COMMON DIMENSIONS			NOTE VARIATIONS	4 D			6 N
	MIN.	NOM.	MAX.		MIN.	NOM.	MAX.	
A	2.41	2.59	2.79	AA	15.75	15.88	16.00	48
A ₁	0.20	0.31	0.41	AB	18.29	18.42	18.54	56
A ₂	2.24	2.29	2.34					
b	0.203	0.254	0.343					
b ₁	0.203	0.254	0.305					
c	0.127	-	0.254					
c ₁	0.127	0.152	0.216					
D	SEE VARIATIONS			4				
E	7.42	7.52	7.59					
e	0.635 BSC							
H	10.16	10.31	10.41					
h	0.25	0.33	0.41					
L	0.61	0.81	1.02					
N	SEE VARIATIONS			6				
X	2.16	2.36	2.54	10				
d ₁	0°	5°	8°					

THIS TABLE IN MILLIMETERS

© Cypress Semiconductor Corporation, 1999. The information contained herein is subject to change without notice. Cypress Semiconductor Corporation assumes no responsibility for the use of any circuitry other than circuitry embodied in a Cypress Semiconductor product. Nor does it convey or imply any license under patent or other rights. Cypress Semiconductor does not authorize its products for use as critical components in life-support systems where a malfunction or failure may reasonably be expected to result in significant injury to the user. The inclusion of Cypress Semiconductor products in life-support systems application implies that the manufacturer assumes all risk of such use and in doing so indemnifies Cypress Semiconductor against all charges.