

**CLM4426 / CLM4427 / CLM4428**

**FEATURES**

- High Peak Output Current ..... >1.5A
- Fast Switching .....  $t_D = 40\text{ns}$
- Wide Operating Range ..... 4.5V to 18V
- Matched Rise and Fall Times
- ESD Protected ..... 4kV

**APPLICATIONS**

- Motor Controls
- Switch Mode Power Supplies
- Pulse Transformer Driver
- Class D Switching Amplifiers

**DESCRIPTION**

The CLM4426 series are dual CMOS drivers are designed to drive capacitive, resistive and inductive loads switching 1000pF gate capacitances in under 30ns while providing low impedances in both the ON and OFF states to insure the MOSFET's intended state will not be affected. All terminals are fully protected up to 4kV of ESD.

**ORDERING INFORMATION**

Part	Logic	Package	Temperature
CLM4426CP	Inverting	8 Pin PDIP	0°C to 70°C
CLM4426EP	Inverting	8 Pin PDIP	-40°C to 85°C
CLM4426CY	Inverting	8 Pin SOIC	0°C to 70°C
CLM4426EY	Inverting	8 Pin SOIC	-40°C to 85°C
CLM4427CP	Noninverting	8 Pin PDIP	0°C to 70°C
CLM4427EP	Noninverting	8 Pin PDIP	-40°C to 85°C
CLM4427CY	Noninverting	8 Pin SOIC	0°C to 70°C
CLM4427EY	Noninverting	8 Pin SOIC	-40°C to 85°C
CLM4428CP	Differential	8 Pin PDIP	0°C to 70°C
CLM4428EP	Differential	8 Pin PDIP	-40°C to 85°C
CLM4428CY	Differential	8 Pin SOIC	0°C to 70°C
CLM4428EY	Differential	8 Pin SOIC	-40°C to 85°C

**FUNCTIONAL DIAGRAM**

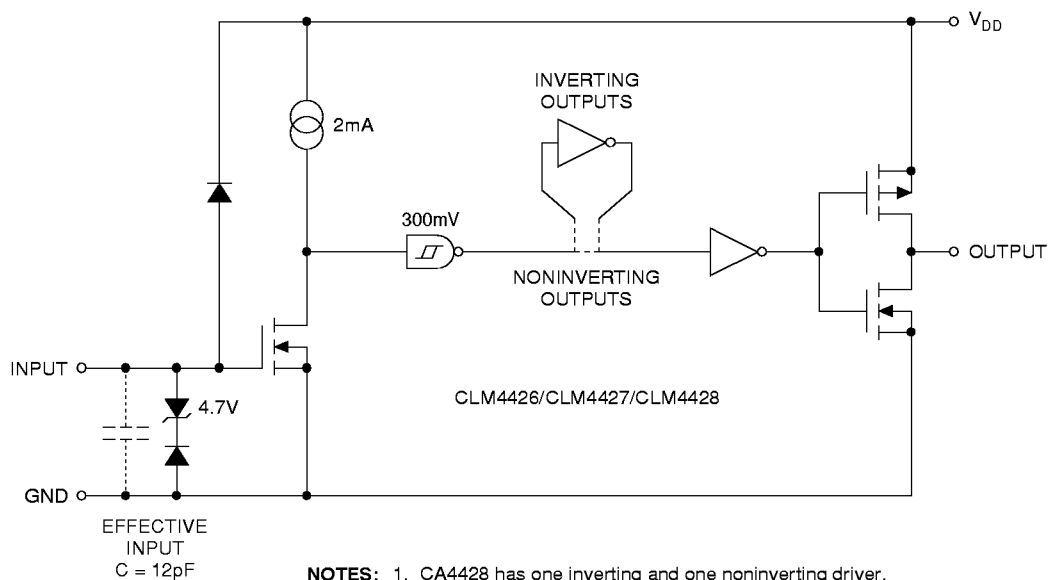

- NOTES:** 1. CA4428 has one inverting and one noninverting driver.  
2. Ground any unused driver input.

**ABSOLUTE MAXIMUM RATINGS**

Supply Voltage	+22V
Input Voltage, IN A or IN B	$V_{DD}+0.3V$ to GND-5.0V
Maximum Chip Temperature	+150°C
Storage Temperature Range	-65°C to +150°C
Lead Temperature (Soldering, 10 sec)	+300°C
Package Thermal Resistance	
PDIP $R_{\theta J-A}$	125°C/W
PDIP $R_{\theta J-C}$	42°C/W
SOIC $R_{\theta J-A}$	250°C/W
SOIC $R_{\theta J-C}$	75°C/W
Operating Temperature Range	
C Version	0°C to +70°C
E Version	-40°C to +85°C
Power Dissipation	
Plastic	1000mW
SOIC	500mW

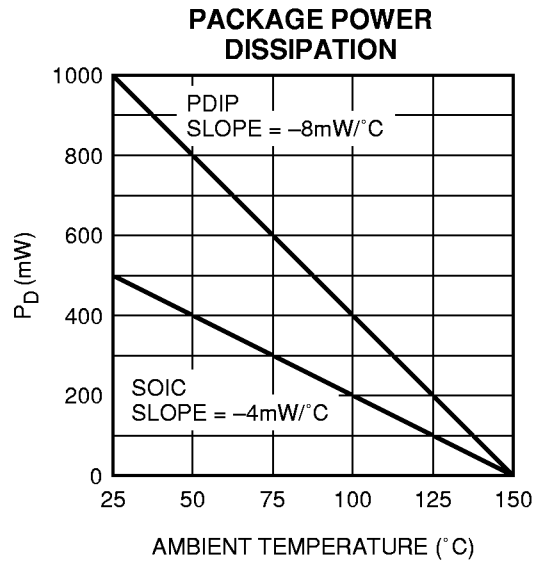

Static-sensitive device. Unused devices must be stored in conductive material. Protect devices from static discharge and static fields. Stresses above those listed under "Absolute Maximum Ratings" may cause permanent damage to the device. These are stress ratings only and functional operation of the device at these or any other conditions above those indicated in the operation sections of the specifications is not implied. Exposure to absolute maximum rating conditions for extended periods may affect device reliability.

1B-38

**ELECTRICAL CHARACTERISTICS**  $T_A = +25^\circ C$  with  $4.5V \leq V_{DD} \leq 18V$ , unless otherwise specified.

SYMBOL	PARAMETER	MIN	TYP	MAX	UNIT	TEST CONDITIONS
<b>INPUT</b>						
$V_{IH}$	Logic 1 High Input Voltage	2.4	-	-	V	
$V_{IL}$	Logic 0 Low Input Voltage	-	-	0.8	V	
$I_{IN}$	Input Current	-1	-	1	$\mu A$	$0V \leq V_{IN} \leq V_{DD}$
<b>OUTPUT</b>						
$V_{OH}$	High Output Voltage	$V_{DD}-0.025$	-	-	V	
$V_{OL}$	Low Output Voltage	-	-	0.025	V	
$R_O$	Output Resistance	-	7	10	$\Omega$	$V_{DD} = 18V, I_O = 10mA$
$I_{PK}$	Peak Output Current	-	1.5	-	A	
$I_{REV}$	Latch-Up Protection Withstand Reverse Current	>0.5	-	-	A	Duty Cycle $\leq 2\%$ $t \leq 300\mu s$
<b>SWITCHING TIME (Note 1)</b>						
$t_R$	Rise Time	-	25	30	ns	Figure 1
$t_F$	Fall Time	-	25	30	ns	Figure 1
$t_{D1}$	Delay Time	-	-	30	ns	Figure 1
$t_{D2}$	Delay Time	-	-	50	ns	Figure 1
<b>POWER SUPPLY</b>						
$I_S$	Power Supply Current	-	-	4.5	mA	$V_{IN} = 3V$ (Both Inputs)
		-	-	0.4	mA	$V_{IN} = 0V$ (Both Inputs)

**Note:** 1. Switching times are guaranteed by design.

**PIN CONFIGURATIONS**

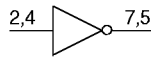
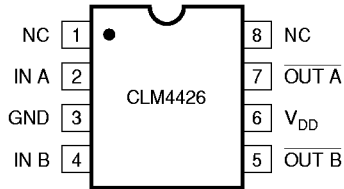

INVERTING

NC = NO INTERNAL CONNECTION

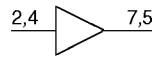
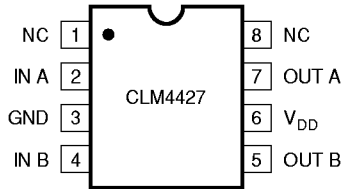

NONINVERTING

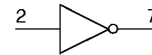
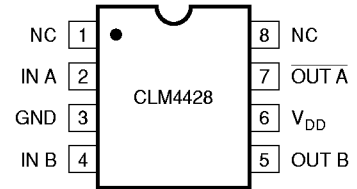

DIFFERENTIAL

NOTE: SOIC pinout is identical to DIP.

IL-12

**ELECTRICAL CHARACTERISTICS**

Specifications measured over temperature range with  $4.5V \leq V_{DD} \leq 18V$ , unless otherwise specified.

SYMBOL	PARAMETER	MIN	TYP	MAX	UNIT	TEST CONDITIONS
<b>INPUT</b>						
$V_{IH}$	Logic 1 High Input Voltage	2.4	-	-	V	
$V_{IL}$	Logic 0 Low Input Voltage	-	-	0.8	V	
$I_{IN}$	Input Current	-1	-	1	$\mu A$	$0V \leq V_{IN} \leq V_{DD}$
<b>OUTPUT</b>						
$V_{OH}$	High Output Voltage	$V_{DD}-0.025$	-	-	V	
$V_{OL}$	Low Output Voltage	-	-	0.025	V	
$R_O$	Output Resistance	-	9	12	$\Omega$	$V_{DD} = 18V, I_O = 10mA$
$I_{PK}$	Peak Output Current	-	1.5	-	A	
$I_{REV}$	Latch-Up Protection Withstand Reverse Current	>0.5	-	-	A	Duty Cycle $\leq 2\%$ $t \leq 300\mu s$
<b>SWITCHING TIME (Note 1)</b>						
$t_R$	Rise Time	-	-	40	ns	Figure 1
$t_F$	Fall Time	-	-	40	ns	Figure 1
$t_{D1}$	Delay Time	-	-	40	ns	Figure 1
$t_{D2}$	Delay Time	-	-	60	ns	Figure 1
<b>POWER SUPPLY</b>						
$I_S$	Power Supply Current	-	-	8	mA	$V_{IN} = 3V$ (Both Inputs)
		-	-	0.6	mA	$V_{IN} = 0V$ (Both Inputs)

Note: 1. Switching times are guaranteed by design.

FIGURE 1. SWITCHING TIME TEST CIRCUIT

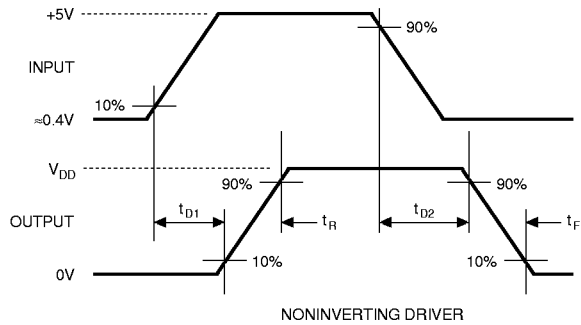
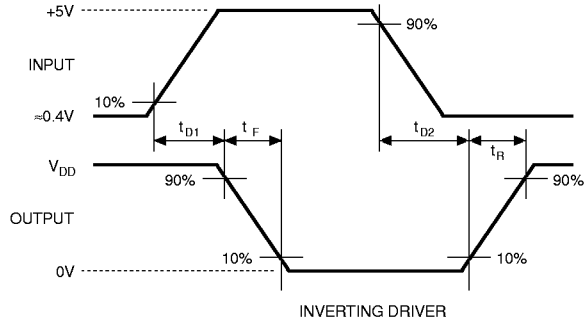
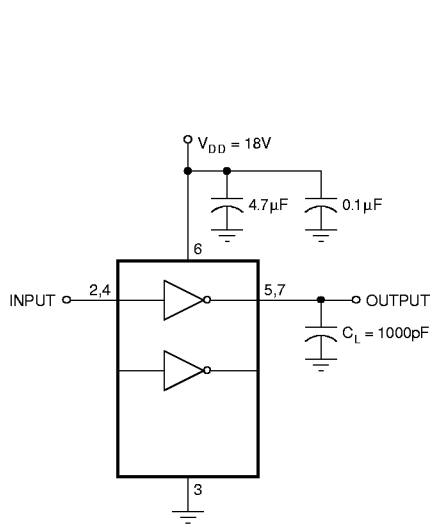

1B-40

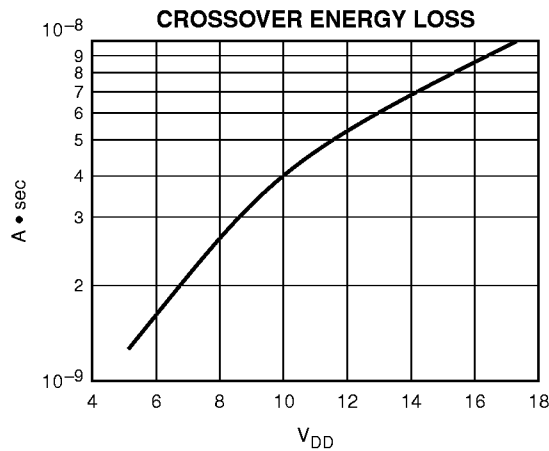

**NOTE:** The values on this graph represent the loss seen by both drivers in a package during one complete cycle. For a single driver, divide the stated values by 2. For a single transition of a single driver, divide the stated value by 4.

1B-41