



Integrated Device Technology, Inc.

16-BIT CMOS MICROPROCESSOR SLICE

**IDT49C402
IDT49C402A
IDT49C402B**

FEATURES:

- Functionally equivalent to four 2901s and one 2902
- IDT49C402B is 60% faster than four 2901Cs and one 2902A
- Expanded two-address architecture with independent, simultaneous access to two 64 x 16 register files
- Expanded destination functions with 8 new operations allowing Direct Data to be loaded directly into the dual-port RAM and Q Register
- Fully cascadable
- 84-pin PGA, 80-pin PQFP and 68-pin 25 MIL Center Flatpack
- Military product compliant to MIL-STD-883, Class B

The IDT49C402s include all of the normal functions associated with standard 2901 bit-slice operation: a) a 3-bit instruction field (I₀, I₁, I₂) which controls the source operand selection for the ALU; b) a 3-bit microinstruction field (I₃, I₄, I₅) used to control the eight possible functions of the ALU; c) eight destination control functions which are selected by the microcode inputs (I₆, I₇, I₈); and d) a tenth microinstruction input, I₉, offering eight additional destination control functions. This I₉ input, in conjunction with I₆, I₇ and I₈, allows for shifting the Q Register up and down, loading the RAM or Q Register directly from the D inputs without going through the ALU, and having the RAM A data output port available at the Y output pins of the device.

Also featured is an on-chip dual-port RAM that contains 64-words-by-16 bits – four times the number of working registers in a 2901.

The IDT49C402s are fabricated using CMOS technology designed for high performance and high reliability. These performance-enhanced devices feature both bipolar speed and bipolar output drive capabilities, while maintaining exceptional microinstruction speeds at greatly reduced CMOS power levels.

DESCRIPTION:

The IDT49C402s are high-speed, fully cascadable 16-bit CMOS microprocessor slice units which combine the standard functions of four 2901s and a 2902 with additional control features aimed at enhancing the performance of bit-slice microprocessor designs.

FUNCTIONAL BLOCK DIAGRAM

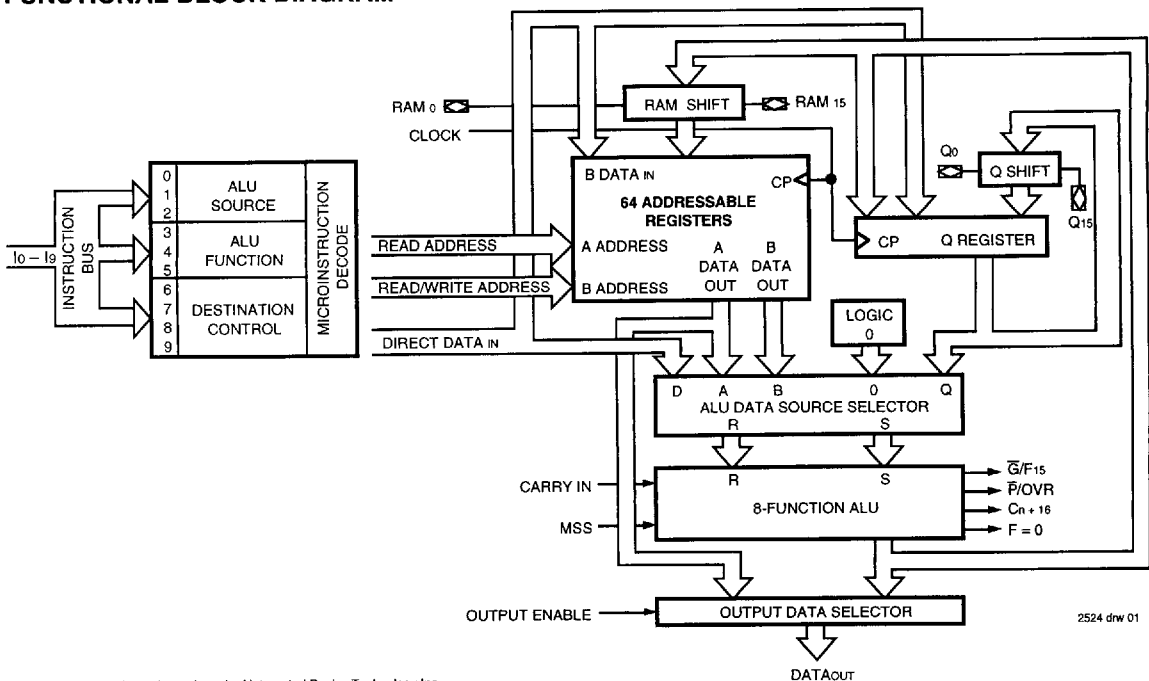

The IDT Logo is registered a trademark of Integrated Device Technology Inc.

MILITARY AND COMMERCIAL TEMPERATURE RANGES

AUGUST 1995

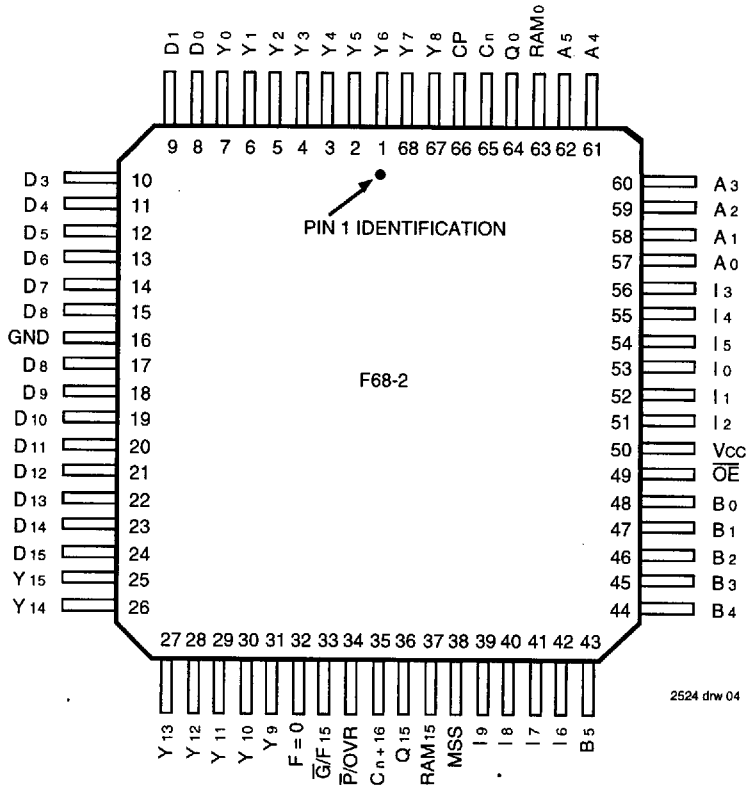

FINE PITCH FLATPACK
TOP VIEW

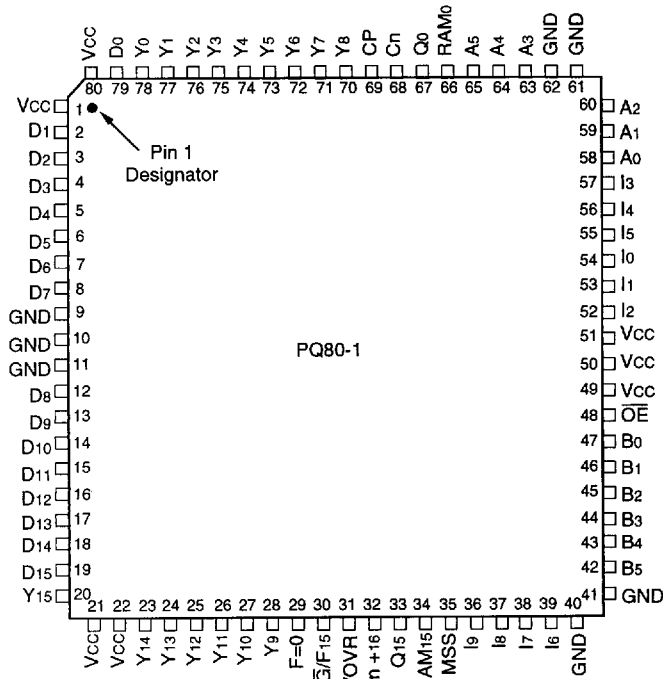

2524 drw 10

**PQFP
 TOP VIEW**

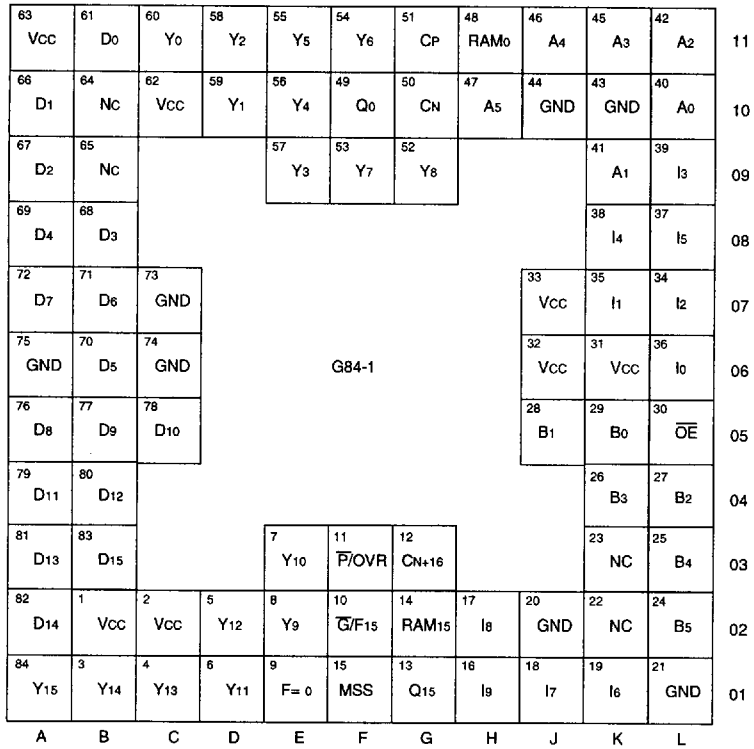

PGA
TOP VIEW

2524 drw 11

PIN DESCRIPTIONS

Pin Name	I/O	Description
A0 - A5	I	Six address inputs to the register file which selects one register and displays its contents through the A port.
B0 - B5	I	Six address inputs to the register file which selects one of the registers in the file, the contents of which is displayed through the B port. It also selects the location into which new data can be written when the clock goes LOW.
I0 - I9	I	Ten instruction control lines which determine what data source will be applied to the ALU I(0, 1, 2), what function the ALU will perform I(3, 4, 5) and what data is deposited in the Q Register or the register file I(6, 7, 8, 9). Original 2901 destinations are selected if I9 is disconnected in this mode, proper I9 bias is achieved by an external pullup resistor to Vcc (47K ohms recommended).
D0 - D15	I	Sixteen-bit direct data inputs which are the data source for entering external data into the device ALU, Q Register or RAM. D0 is the LSB.
Y0 - Y15	O	Sixteen three-state output lines which, when enabled, display either the sixteen outputs of the ALU or the data on the A port of the register stack. This is determined by the destination code I(6, 7, 8, 9).
$\bar{G}/F15$	O	A multipurpose pin which indicates the carry generate (\bar{G}) function at the least significant and intermediate slices or as F15, the most significant ALU output (sign bit). $\bar{G}/F15$ selection is controlled by the MSS pin. If MSS = HIGH, F15 is enabled. If MSS = LOW, \bar{G} is enabled.
F = 0	O	Open drain output which goes HIGH if the F0 - F15 ALU outputs are all LOW. This indicates that the result of an ALU operation is zero (positive logic).
Cn	I	Carry-in to the internal ALU.
Cn+16	O	Carry-out of the ALU.
Q15 RAM15	I/O	Bidirectional lines controlled by I(6, 7, 8, 9). Both are three-state output drivers connected to the TTL-compatible inputs. When the destination code on I(6, 7, 8, 9) indicates an up shift, the three-state outputs are enabled, the MSB of the Q Register is available on the Q15 pin and the MSB of the ALU output is available on the RAM15 pin. When the destination code indicates a down shift, the pins are the data inputs to the MSB of the Q Register and the MSB of the RAM.
Q0 RAM0	I/O	Both bidirectional lines function identically to Q15 and RAM15 lines except they are the LSB of the Q Register and RAM.
\bar{OE}	I	Output enable. When pulled HIGH, the Y outputs are OFF (high impedance). When pulled LOW, the Y outputs are enabled.
\bar{P}/OVR	O	A multipurpose pin which indicates the carry propagate (\bar{P}) output for performing a carry lookahead operation or overflow (OVR) the Exclusive-OR of the carry-in and carry-out of the ALU MSB. OVR, at the most significant end of the word, indicates that the result of an arithmetic two's complement operation has overflowed into the sign bit. \bar{P}/OVR selection is controlled by the MSS pin. If MSS = HIGH, OVR is enabled. If MSS = LOW, \bar{P} is enabled.
CP	I	The clock input LOW-to-HIGH clock transitions will change the Q Register and the register file outputs. Clock LOW time is internally the write enable time for the 64 x 16 RAM. While the clock is LOW, the slave latches on the RAM outputs are closed, storing the data previously on the RAM outputs. Synchronous MASTER-SLAVE operation of the register file is achieved by this.
MSS	I	When HIGH, enables OVR and F15 on the \bar{P}/OVR and $\bar{G}/F15$ pins. When LOW, enables \bar{G} and \bar{P} on these pins. If left open, internal pullup resistor to Vcc provides declaration that the device is the most significant slice.

2524 tbl 01

DEVICE ARCHITECTURE

The IDT49C402 CMOS bit-slice microprocessor is configured sixteen bits wide and is cascadable to any number of bits (16, 32, 48, 64). Key elements which make up this 16-bit microprocessor slice are the 1) register file (64 x 16 dual-port RAM) with shifter 2) ALU and 3) Q Register and shifter.

REGISTER FILE — A 16-bit data word from one of the 64 RAM registers can read from the A port as selected by the 6-bit A address field. Simultaneously, the same data word, or any other word from the 64 RAM registers, can be read from the B port as selected by the 6-bit B address field. New data is written into the RAM register location selected by the B address field during the clock (CP) LOW time. Two sixteen-bit latches hold the RAM A port and B port during the clock (CP) LOW time, eliminating any data races. During clock HIGH, these latches are transparent, reading the data selected by the A and B addresses. The RAM data input field is driven from a four-input multiplexer that selects the ALU output or the D inputs. The ALU output can be shifted up one position, down one position or not shifted. Shifting data operations involves the RAM₁₅ and RAM₀ I/O pins. For a shift up operation, the RAM shifter MSB is connected to an enabled RAM₁₅ I/O output, while the RAM₀ I/O input is selected as the input to the LSB. During a shift down operation, the RAM shifter LSB is connected to an enabled RAM₀ I/O output, while the RAM₁₅ I/O input is selected as the input to the MSB.

ALU — The ALU can perform three binary arithmetic and five logic operations on the two 16-bit input words S and R. The S input field is driven from a 3-input multiplexer and the R input field is driven from a 2-input multiplexer, with both having a zero source operand. Both multiplexers are controlled by the I(0, 1, 2) inputs. This multiplexer configuration enables the user to select the various pairs of the A, B, D, Q and "0" inputs as source operands to the ALU. Microinstruction inputs I(3, 4, 5) are used to select the ALU function. This high-speed ALU cascades to any word length, providing carry-in (C_n), carry-out (C_{n+16}) and an open-drain (F = 0) output. When all bits of the

ALU are zero, the pull-down device of F = 0 is off, allowing a wire-OR of this pin over all cascaded devices. Multipurpose pins \bar{G}/F_{15} and \bar{P}/OVR are aimed at accelerating arithmetic operations. For intermediate and least significant slices, the MSS pin is programmed LOW, selecting the carry-generate (\bar{G}) and carry propagate (\bar{P}) output functions to be used by carry lookahead logic. For the most significant slice, MSS is programmed HIGH, selecting the sign-bit (F₁₅) and the two's complement overflow (OVR) output functions. The sign bit (F₁₅) allows the ALU sign bit to be monitored without enabling the three-state ALU outputs. The overflow (OVR) output is high when the two's complement arithmetic operation has overflowed into the sign bit, as logically determined from the Exclusive-OR of the carry-in and carry-out of the most significant bit of the ALU. The ALU data outputs are available at the three-state outputs Y(0-15) or as inputs to the RAM register file and Q register under control of the I(6, 7, 8, 9) instruction inputs.

Q REGISTER — The Q Register is a separate 16-bit file intended for multiplication and division routines and can also be used as an accumulator or holding register for other types of applications. It is driven from a 4-input multiplexer. In the no-shift mode, the multiplexer enters the ALU F output or Direct Data into the Q Register. In either the shift up or shift down mode, the multiplexer selects the Q Register data appropriately shifted up or down. The Q shifter has two ports, Q₀ and Q₁₅, which operate comparably to the RAM shifter. They are controlled by the I(6, 7, 8, 9) inputs.

The clock input of the IDT49C402 controls the RAM, Q Register and A and B data latches. When enabled, the data is clocked into the Q Register on the LOW-to-HIGH transition. When the clock is HIGH, the A and B latches are open and pass data that is present at the RAM outputs. When the clock is LOW, the latches are closed and retain the last data entered. When the clock is LOW and I(6, 7, 8, 9) define the RAM as the destination, new data will be written into the RAM file defined by the B address field.

ALU SOURCE OPERAND CONTROL

Mnemonic	Microcode				ALU Source Operands	
	I ₂	I ₁	I ₀	Octal Code	R	S
AQ	L	L	L	0	A	Q
AB	L	L	H	1	A	B
ZQ	L	H	L	2	0	Q
ZB	L	H	H	3	0	B
ZA	H	L	L	4	0	A
DA	H	L	H	5	D	A
DQ	H	H	L	6	D	Q
DZ	H	H	H	7	D	0

2524 tbl 02

ALU FUNCTION CONTROL

Mnemonic	Microcode				ALU Function	Symbol
	I ₂	I ₁	I ₀	Octal Code		
ADD	L	L	L	0	R Plus S	R + S
SUBR	L	L	H	1	S Minus R	S - R
SUBS	L	H	L	2	R Minus S	R - S
OR	L	H	H	3	R OR S	R ∨ S
AND	H	L	L	4	R AND S	R ∧ S
NOTRS	H	L	H	5	\bar{R} AND S	$\bar{R} \wedge S$
EXOR	H	H	L	6	R EX-OR S	R ⊕ S
EXNOR	H	H	H	7	R EX-NOR S	$\overline{R \oplus S}$

2524 Tbl 04

ALU ARITHMETIC MODE FUNCTIONS

Octal		C _n = L		C _n = H	
I ₅ , 4, 3	I ₂ , 1, 0	Group	Function	Group	Function
0	0	ADD	A + Q	ADD plus one	A + Q + 1
0	1		A + B		A + B + 1
0	5		D + A		D + A + 1
0	6		D + Q		D + Q + 1
0	2	PASS	Q	Increment	Q + 1
0	3		B		B + 1
0	4		A		A + 1
0	7		D		D + 1
1	2	Decrement	Q - 1	PASS	Q
1	3		B - 1		B
1	4		A - 1		A
2	7		D - 1		D
2	2	1's Comp.	-Q - 1	2's Comp. (Negate)	-Q
2	3		-B - 1		-B
2	4		-A - 1		-A
1	7		-D - 1		-D
1	0	Subtract (1's Comp)	Q - A - 1	Subtract (2's Comp)	Q - A
1	1		B - A - 1		B - A
1	5		A - D - 1		A - D
1	6		Q - D - 1		Q - D
2	0		A - Q - 1		A - Q
2	1		A - B - 1		A - B
2	5		D - A - 1		D - A
2	6		D - Q - 1		D - Q

2524 tbl 03

ALU LOGIC MODE FUNCTIONS

Octal		Group	Function
I ₅ , 4, 3	I ₂ , 1, 0		
4	0	AND	A ∧ Q
4	1		A ∧ B
4	5		D ∧ A
4	6		D ∧ Q
3	0	OR	A ∨ Q
3	1		A ∨ B
3	5		D ∨ A
3	6		D ∨ Q
6	0	EX-OR	A ⊕ Q
6	1		A ⊕ B
6	5		D ⊕ A
6	6		D ⊕ Q
7	0	EX-NOR	$\overline{A \oplus Q}$
7	1		$\overline{A \oplus B}$
7	5		$\overline{D \oplus A}$
7	6		$\overline{D \oplus Q}$
7	2	INVERT	\bar{Q}
7	3		\bar{B}
7	4		\bar{A}
7	7		\bar{D}
6	2		PASS
6	3	B	
6	4	A	
6	7	D	
3	2	PASS	Q
3	3		B
3	4		A
3	7		D
4	2	"ZERO"	0
4	3		0
4	4		0
4	7		0
5	0	MASK	$\bar{A} \wedge Q$
5	1		$\bar{A} \wedge B$
5	5		$\bar{D} \wedge A$
5	6		$\bar{D} \wedge Q$

2524 Tbl 05

SOURCE OPERAND AND ALU FUNCTION MATRIX (1)

Octal Is, 4, 3	ALU Function	2, 1, 0 Octal							
		0	1	2	3	4	5	6	7
		ALU Source							
		A, Q	A, B	0, Q	0, B	0, A	D, A	D, Q	D, 0
0	Cn = L R Plus S Cn = H	A + Q	A + B	Q	B	A	D + A	D + Q	D
		A + Q + 1	A + B + 1	Q + 1	B + 1	A + 1	D + A + 1	D + Q + 1	D + 1
1	Cn = L S Minus R Cn = H	Q - A - 1	B - A - 1	Q - 1	B - 1	A - 1	A - D - 1	Q - D - 1	-D - 1
		Q - A	B - A	Q	B	A	A - D	Q - D	-D
2	Cn = L R Minus S Cn = H	A - Q - 1	A - B - 1	-Q - 1	-B - 1	-A - 1	D - A - 1	D - Q - 1	D - 1
		A - Q	A - B	-Q	-B	-A	D - A	D - Q	D
3	R O R S	A ∨ Q	A ∨ B	Q	B	A	D ∨ A	D ∨ Q	D
4	R A N D S	A ∧ Q	A ∧ B	0	0	0	D ∧ A	D ∧ Q	0
5	R̄ A N D S	$\bar{A} \wedge Q$	$\bar{A} \wedge B$	Q	B	A	$\bar{D} \wedge A$	$\bar{D} \wedge Q$	0
6	R E X - O R S	A ∇ Q	A ∇ B	Q	B	A	D ∇ A	D ∇ Q	D
7	R E X - N O R S	$\overline{A \nabla Q}$	$\overline{A \nabla B}$	\bar{Q}	\bar{B}	\bar{A}	$\overline{D \nabla A}$	$\overline{D \nabla Q}$	\bar{D}

NOTE:

1. + = Plus; - = Minus; ∧ = AND; ∇ = EX-OR; ∨ = OR.

2524 Tbl 06

ALU DESTINATION CONTROL (1)

Mnemonic	Microcode					RAM Function		Q Register Function		Y Output	RAM Shifter		Q Shifter		
	Is	I8	I7	I6	Hex Code	Shift	Load	Shift	Load		RAM0	RAM15	Q0	Q15	
OREG	H	L	L	L	8	X	NONE	NONE	F → Q	F	X	X	X	X	Existing 2901 Functions
NOP	H	L	L	H	9	X	NONE	X	NONE	F	X	X	X	X	
RAMA	H	L	H	L	A	NONE	F → B	X	NONE	A	X	X	X	X	
RAMF	H	L	H	H	B	NONE	F → B	X	NONE	F	X	X	X	X	
RAMQD	H	H	L	L	C	DOWN	F/2 → B	DOWN	Q/2 → Q	F	F0	IN15	Q0	IN15	
RAMD	H	H	L	H	D	DOWN	F/2 → B	X	NONE	F	F0	IN15	Q0	X	
RAMQU	H	H	H	L	E	UP	2F → B	UP	2Q → Q	F	IN0	F15	IN0	Q15	
RAMU	H	H	H	H	F	UP	2F → B	X	NONE	F	IN0	F15	X	Q15	
DFF	L	L	L	L	0	NONE	D → B	NONE	F → Q	F	X	X	X	X	New Added IDT49C402 Functions
DFA	L	L	L	H	1	NONE	D → B	NONE	F → Q	A	X	X	X	X	
PDF	L	L	H	L	2	NONE	F → B	NONE	D → Q	F	X	X	X	X	
FDA	L	L	H	H	3	NONE	F → B	NONE	D → Q	A	X	X	X	X	
XQDF	L	H	L	L	4	X	NONE	DOWN	Q/2 → Q	F	X	X	Q0	IN15	
DXF	L	H	L	H	5	NONE	D → B	X	NONE	F	X	X	Q0	X	
XQUF	L	H	H	L	6	X	NONE	UP	2Q → Q	F	X	X	IN0	Q15	
XDF	L	H	H	H	7	X	NONE	NONE	D → Q	F	X	X	X	Q15	

NOTE:

1. X = Don't care. Electrically, the shift pin is a TTL input internally connected to a three-state output which is in the impedance state.
B = Register Addressed by B inputs.
UP is toward MSB; DOWN is toward LSB.

2524 Tbl 07

ABSOLUTE MAXIMUM RATINGS⁽¹⁾

Symbol	Rating	Com'l.	Mil.	Unit
VCC	Power Supply Voltage	-0.5 to +7.0	-0.5 to +7.0	V
VTERM	Terminal Voltage with Respect to Ground	-0.5 to VCC + 0.5	-0.5 to VCC + 0.5	V
TA	Operating Temperature	0 to +70	-55 to +125	°C
TBIAS	Temperature Under Bias	-55 to +125	-65 to +135	°C
TSTG	Storage Temperature	-55 to +125	-65 to +150	°C
PT	Power Dissipation	1.5	1.5	W
IOUT	DC Output Current	50	50	mA

NOTE: 2524 tbl 08
1. Stresses greater than those listed under ABSOLUTE MAXIMUM RATINGS may cause permanent damage to the device. This is a stress rating only and functional operation of the device at these or any other conditions above those indicated in the operational sections of this specification is not implied. Exposure to absolute maximum rating conditions for extended periods may affect reliability.

CAPACITANCE (TA = +25°C, f = 1.0MHz)

Symbol	Parameter ⁽¹⁾	Conditions	Typ.	Unit
CIN	Input Capacitance	VIN = 0V	5	pF
COUT	Output Capacitance	VOUT = 0V	7	pF

NOTE: 2524 tbl 09
1. This parameter is sampled and not 100% tested.

DC ELECTRICAL CHARACTERISTICS

Commercial: TA = 0°C to +70°C, VCC = 5.0V ± 5%; Military: TA = -55°C to +125°C, VCC = 5.0V ± 10%

Symbol	Parameter	Test Conditions ⁽¹⁾	Min.	Typ. ⁽²⁾	Max.	Unit	
VIH	Input HIGH Level	Guaranteed Logic High Level	2.0	-	-	V	
VIL	Input LOW Level	Guaranteed Logic Low Level	-	-	0.8	V	
IiH	Input HIGH Current	VCC = Max., VIN = VCC	-	0.1	5	µA	
IiL	Input LOW Current	VCC = Max., VIN = GND	-	-0.1	-5	µA	
VoH	Output HIGH Voltage	VCC = Min. VIN = VIH or VIL	IoH = -6mA MIL. IoH = -8mA COM'L.	2.4 2.4	4.3 4.3	- -	V
VoL	Output LOW Voltage	VCC = Min. VIN = VIH or VIL	IoL = 8mA MIL. IoL = 10mA COM'L.	- -	0.3 0.3	0.5 0.5	V
IoZ	Off State (High Impedance) Output Current	VCC = Max.	Vo = 0V Vo = VCC (Max.)	- -	-0.1 0.1	-10 10	µA
Ios	Output Short Circuit Current	VCC = Max., VOUT = 0V ⁽³⁾	-15	-30	-70	mA	

NOTES: 2524 tbl 10
1. For conditions shown as Max. or Min., use appropriate value specified under Electrical Characteristics.
2. Typical values are at VCC = 5.0V, +25°C ambient and maximum loading, not production tested.
3. Not more than one output should be shorted at one time. Duration of the circuit test should not exceed one second.

DC ELECTRICAL CHARACTERISTICS

Commercial: TA = 0°C to +70°C, VCC = 5.0V ± 5%; Military: TA = -55°C to +125°C, VCC = 5.0V ± 10%

Symbol	Parameter	Test Conditions ⁽¹⁾		Min.	Typ. ⁽²⁾	Max.	Unit
I _{CCQH}	Quiescent Power Supply Current CP = H (CMOS Inputs)	V _{CC} = Max.	MIL.	-	-	10	mA
		V _{IH} = V _{CC} , V _{IL} = 0V f _{CP} = 0, CP = H	COM'L.	-	-	10	
I _{CCQL}	Quiescent Power Supply Current CP = L (CMOS Inputs)	V _{CC} = Max.	MIL.	-	-	10	mA
		V _{IH} = V _{CC} , V _{IL} = 0V f _{CP} = 0, CP = L	COM'L.	-	-	10	
I _{CCIT}	Quiescent Input Power Supply ⁽⁶⁾ Current (per Input @ TTL High)	V _{CC} = Max., V _{IH} = 3.4V, f _{CP} = 0	MIL.	-	-	1.5	mA/ Input
			COM'L.	-	-	0.85	
I _{CCD}	Dynamic Power Supply Current	V _{CC} = Max.	MIL.	-	-	7.5	mA/ MHz
		V _{IH} = V _{CC} , V _{IL} = 0V Outputs Open, \overline{OE} = L	COM'L.	-	-	4.5	
I _{CC}	Total Power Supply Current ⁽⁷⁾	V _{CC} = Max., f _{CP} = 10MHz Outputs Open, \overline{OE} = L	MIL.	-	-	85	mA
		CP = 50 % Duty cycle V _{IH} = V _{CC} , V _{IL} = 0V	COM'L.	-	-	55	
		V _{CC} = Max., f _{CP} = 10MHz Outputs Open, \overline{OE} = L	MIL.	-	-	130	
		CP = 50 % Duty cycle V _{IH} = 3.4V, V _{IL} = 0.4V	COM'L.	-	-	95	

2524 IBI 11

NOTES:

- For conditions shown as Max. or Min., use appropriate value specified under Electrical Characteristics.
- Typical values are at V_{CC} = 5.0V, +25°C ambient and maximum loading, not production tested.
- Not more than one output should be shorted at one time. Duration of the circuit test should not exceed one second.
- These input levels provide zero noise immunity and should only be static tested in a noise-free environment.
- Guaranteed by design, not production tested.
- I_{CCIT} is derived by measuring the total current with all the inputs tied together at 3.4V, subtracting out I_{CCQH}, then dividing by the total number of inputs.
- Total Supply Current is the sum of the Quiescent current and the Dynamic current (at either CMOS or TTL input levels). For all conditions, the Total Supply Current can be calculated by using the following equation:
 $I_{CC} = I_{CCQH} (CDH) + I_{CCQL} (1 - CDH) + I_{CCIT} (N_T \times DH) + I_{CCD} (f_{CP} / 2 + f_i N_i)$
 CDH = Clock duty cycle high period
 DH = Data duty cycle TTL high period (V_{IH} = 3.4V)
 N_T = Number of dynamic inputs driven at TTL levels
 f_{CP} = Clock input frequency
 I_{CCIT} = Quiescent Power Supply Current for TTL level inputs
 I_{CCD} = Dynamic Power Supply Current in mA/MHz
 f_i = Input frequency
 N_i = Number of inputs switching

AC ELECTRICAL CHARACTERISTICS

IDT49C402

(Military and Commercial Temperature Ranges)

The tables below specify the guaranteed performance of the IDT49C402 over the -55°C to +125°C and 0°C to +70°C temperature ranges. Vcc is specified at 5V ± 10% for military temperature range and 5V ± 5% for commercial temperature range. All times are in nanoseconds and are measured at the 1.5V signal level. The inputs switch between 0V and 3V with signal transition rates of 1V per nanosecond. All outputs have maximum DC current loads.

CYCLE TIME AND CLOCK CHARACTERISTICS

	Mil. (6)	Com'l.	Unit
Read-Modify-Write Cycle (from selection of A, B registers to end of cycle)	50	48	ns
Maximum Clock Frequency to shift Q (50% duty cycle, I = C32 or E32)	20	21	MHz
Minimum Clock LOW Time	30	25	ns
Minimum Clock HIGH Time	20	20	ns
Minimum Clock Period	50	48	ns

2524 tbl 13

MAXIMUM COMBINATIONAL PROPAGATION DELAYS⁽¹⁾ CL = 50pF

From Input	To Output																Unit
	Y		(MSS = L) G, P		(MSS = H) F15 OVR				Cn + 16		F = 0		RAM0 RAM15		Q0 Q15		
	Mil.	Com'l.	Mil.	Com'l.	Mil.	Com'l.	Mil.	Com'l.	Mil.	Com'l.	Mil.	Com'l.	Mil.	Com'l.	Mil.	Com'l.	
A, B Address	52	47	47	42	52	47	47	42	38	34	52	47	44	40	-	-	ns
D	35	32	34	31	35	32	34	31	27	25	35	32	28	26	-	-	ns
Cn	29	26	-	-	29	26	27	25	20	18	29	26	23	21	-	-	ns
Io, 1, 2	41	37	30	27	41	37	38	35	29	26	41	37	30	27	-	-	ns
I3, 4, 5	40	36	28	26	40	36	37	34	27	25	40	36	28	26	-	-	ns
I6, 7, 8, 9	26	24	-	-	-	-	-	-	-	-	-	-	20	18	20	18	ns
A Bypass ALU (I = AXX, 1XX, 3XX)	30	27	-	-	-	-	-	-	-	-	-	-	-	-	-	-	ns
Clock	42	38	41	37	42	38	41	37	30	27	42	38	41	37	25	23	ns

2524 tbl 14

MINIMUM SET-UP AND HOLD TIMES RELATIVE TO CLOCK (CP INPUT)

Input	CP: 								Unit
	Set-up Time Before H → L		Hold Time After H → L		Set-up Time Before L → H		Hold Time After L → H		
	Mil.	Com'l.	Mil.	Com'l.	Mil.	Com'l.	Mil.	Com'l.	
A, B Source Address	20	18	2 ⁽³⁾	1 ⁽³⁾	50 ⁽⁴⁾	50 ⁽⁴⁾	2	1	ns
B Destination Address	20	18	Do not change ⁽²⁾				2	1	ns
D	-(1)	-	-	-	30/40 ⁽⁵⁾	26/36 ⁽⁵⁾	2	1	ns
Cn	-	-	-	-	35	32	0	0	ns
Io, 1, 2	-	-	-	-	45	41	0	0	ns
I3, 4, 5	-	-	-	-	45	41	0	0	ns
I6, 7, 8, 9	12	11	Do not change ⁽²⁾				0	0	ns
RAM0,15, Q0,15	-	-	-	-	12	11	0	0	ns

NOTES:

2524 tbl 15

1. A dash indicates a propagation delay or set-up time constraint does not exist.
2. Certain signals must be stable during the entire clock LOW time to avoid erroneous operation.
3. Source addresses must be stable prior to the H → L transition to allow time to access the source data before the latches close. The A address may then be changed. The B address could be changed if it is not a destination: i.e., if data is not being written back into the RAM. Normally A and B are not changed during the clock LOW time.
4. The set-up time prior to the clock L → H transition is to allow time for data to be accessed, passed through the ALU and returned to the RAM. It includes all the time from stable A and B addresses to the clock L → H transition, regardless of when the H → L transition occurs.
5. First value is direct path (DATA_{IN} → RAM/Q Register). Second value is indirect path (DATA_{IN} → ALU → RAM/Q Register).
6. Guaranteed by design, not production tested.

AC ELECTRICAL CHARACTERISTICS

IDT49C402A

(Military and Commercial Temperature Ranges)

The tables below specify the guaranteed performance of the IDT49C402A over the -55°C to +125°C and 0°C to +70°C temperature ranges. Vcc is specified at 5V ± 10% for military temperature range and 5V ± 5% for commercial temperature range. All times are in nanoseconds and are measured at the 1.5V signal level. The inputs switch between 0V and 3V with signal transition rates of 1V per nanosecond. All outputs have maximum DC current loads.

CYCLE TIME AND CLOCK CHARACTERISTICS

	Mil. ⁽⁶⁾	Com'l.	Unit
Read-Modify-Write Cycle (from selection of A, B registers to end of cycle) ⁽⁶⁾	23	22	ns
Maximum Clock Frequency to shift Q (50% duty cycle, I = C32 or E32) ⁽⁶⁾	35	41	MHz
Minimum Clock LOW Time	13	11	ns
Minimum Clock HIGH Time	13	11	ns
Minimum Clock Period ⁽⁶⁾	36	31	ns

2524 tbl 16

MAXIMUM COMBINATIONAL PROPAGATION DELAYS⁽¹⁾ CL = 50pF

From Input	To Output																Unit
	Y		(MSS = L) Q̄, P̄		(MSS = H) F15 OVR				Cn+16		F = 0		RAM0 RAM15		Q0 Q15		
	Mil.	Com'l.	Mil.	Com'l.	Mil.	Com'l.	Mil.	Com'l.	Mil.	Com'l.	Mil.	Com'l.	Mil.	Com'l.	Mil.	Com'l.	
A, B Address	41	37	39	35	41	37	41	37	37	34	41	37	40	36	-	-	ns
D	32	29	29	26	29	26	31	28	27	25	32	29	28	26	-	-	ns
Cn	28	25	-	-	26	24	25	23	20	18	29	26	23	21	-	-	ns
Io, 1, 2	35	32	30	27	35	32	34	31	29	26	35	32	30	27	-	-	ns
I3, 4, 5	35	32	28	26	34	31	34	31	27	25	35	32	28	26	-	-	ns
I6, 7, 8, 9	25	23	-	-	-	-	-	-	-	-	-	-	20	18	20	18	ns
A Bypass ALU (I = AX, 1XX, 3XX)	30	27	-	-	-	-	-	-	-	-	-	-	-	-	-	-	ns
Clock	34	31	31	28	33	30	34	31	30	27	34	31	34	31	25	23	ns

2524 tbl 17

MINIMUM SET-UP AND HOLD TIMES RELATIVE TO CLOCK (CP INPUT)

Input	CP:								Unit
	Set-up Time Before H → L		Hold Time After H → L		Set-up Time Before L → H		Hold Time After L → H		
	Mil.	Com'l.	Mil.	Com'l.	Mil.	Com'l.	Mil.	Com'l.	
A, B Source Address	11	10	2 ⁽³⁾	1 ⁽³⁾	25 ⁽⁴⁾	21 ⁽⁴⁾	2	1	ns
B Destination Address	11	10	Do not change ⁽²⁾				2	1	ns
D	- ⁽¹⁾	-	-	-	12/22 ⁽⁵⁾	10/20 ⁽⁵⁾	2	1	ns
Cn	-	-	-	-	17	15	0	0	ns
Io, 1, 2	-	-	-	-	28	25	0	0	ns
I3, 4, 5	-	-	-	-	28	25	0	0	ns
I6, 7, 8, 9	11	10	Do not change ⁽²⁾				0	0	ns
RAM0,15, Q0,15	-	-	-	-	12	11	0	0	ns

2524 tbl 18

NOTES:

1. A dash indicates a propagation delay or set-up time constraint does not exist.
2. Certain signals must be stable during the entire clock LOW time to avoid erroneous operation.
3. Source addresses must be stable prior to the H → L transition to allow time to access the source data before the latches close. The A address may then be changed. The B address could be changed if it is not a destination: i.e., if data is not being written back into the RAM. Normally A and B are not changed during the clock LOW time.
4. The set-up time prior to the clock L → H transition is to allow time for data to be accessed, passed through the ALU and returned to the RAM. It includes all the time from stable A and B addresses to the clock L → H transition, regardless of when the H → L transition occurs.
5. First value is direct path (DATA_{IN} → RAM/Q Register). Second value is indirect path (DATA_{IN} → ALU → RAM/Q Register).
6. Guaranteed by design, not production tested.

AC ELECTRICAL CHARACTERISTICS

IDT49C402B

(Military and Commercial Temperature Ranges)

The tables below specify the guaranteed performance of the IDT49C402B over the -55°C to +125°C and 0°C to +70°C temperature ranges. V_{CC} is specified at 5V ± 10% for military temperature range and 5V ± 5% for commercial temperature range. All times are in nanoseconds and are measured at the 1.5V signal level. The inputs switch between 0V and 3V with signal transition rates of 1V per nanosecond. All outputs have maximum DC current loads.

CYCLE TIME AND CLOCK CHARACTERISTICS

	Mil. ⁽⁶⁾	Com'l.	Unit
Read-Modify-Write Cycle (from selection of A, B registers to end of cycle) ⁽⁶⁾	22	19	ns
Maximum Clock Frequency to shift Q (50% duty cycle, I = C32 or E32) ⁽⁶⁾	52	60	MHz
Minimum Clock LOW Time	11	9	ns
Minimum Clock HIGH Time	11	9	ns
Minimum Clock Period ⁽⁶⁾	24	20	ns

2524 tbl 19

MAXIMUM COMBINATIONAL PROPAGATION DELAYS⁽¹⁾ CL = 50pF

From Input	To Output																Unit
	Y		(MSS = L) G, P		(MSS = H) F15 OVR				C _{n+16}		F = 0		RAM ₀ RAM ₁₅		Q ₀ Q ₁₅		
	Mil.	Com'l.	Mil.	Com'l.	Mil.	Com'l.	Mil.	Com'l.	Mil.	Com'l.	Mil.	Com'l.	Mil.	Com'l.	Mil.	Com'l.	
A, B Address	33	28	31	26	31	28	31	28	28	26	31	28	32	29	-	-	ns
D	26	23	23	21	23	21	25	22	22	20	26	23	24	23	-	-	ns
C _n	22	20	-	-	20	18	19	17	15	14	22	20	18	17	-	-	ns
l _{0, 1, 2}	28	26	24	22	28	26	27	25	23	21	28	26	26	24	-	-	ns
l _{3, 4, 5}	28	26	22	21	27	25	27	25	22	20	28	26	25	23	-	-	ns
l _{6, 7, 8, 9}	20	18	-	-	-	-	-	-	-	-	-	-	16	14	16	14	ns
A Bypass ALU (I = AXX, 1XX, 3XX)	24	22	-	-	-	-	-	-	-	-	-	-	-	-	-	-	ns
Clock \overline{f}	27	25	25	22	26	24	27	25	25	22	27	25	27	25	20	18	ns

2524 tbl 20

MINIMUM SET-UP AND HOLD TIMES RELATIVE TO CLOCK (CP INPUT)

Input	CP: 										Unit
	Set-up Time Before H → L		Hold Time After H → L		Set-up Time Before L → H		Hold Time After L → H				
	Mil.	Com'l.	Mil.	Com'l.	Mil.	Com'l.	Mil.	Com'l.	Mil.	Com'l.	
A, B Source Address	10	9	2 ⁽³⁾	1 ⁽³⁾	20 ⁽⁴⁾	18 ⁽⁴⁾	2	1			ns
B Destination Address	10	9	Do not change ⁽²⁾				2	1			ns
D	- ⁽¹⁾	-	-	-	12/22 ⁽⁵⁾	10/20 ⁽⁵⁾	2	1			ns
C _n	-	-	-	-	16	14	0	0			ns
l _{0, 1, 2}	-	-	-	-	26	24	0	0			ns
l _{3, 4, 5}	-	-	-	-	26	24	0	0			ns
l _{6, 7, 8, 9}	10	9	Do not change ⁽²⁾				0	0			ns
RAM _{0,15} , Q _{0,15}	-	-	-	-	12	10	0	0			ns

2524 tbl 21

NOTES:

1. A dash indicates a propagation delay or set-up time constraint does not exist.
2. Certain signals must be stable during the entire clock LOW time to avoid erroneous operation.
3. Source addresses must be stable prior to the H → L transition to allow time to access the source data before the latches close. The A address may then be changed. The B address could be changed if it is not a destination: i.e., if data is not being written back into the RAM. Normally A and B are not changed during the clock LOW time.
4. The set-up time prior to the clock L → H transition is to allow time for data to be accessed, passed through the ALU and returned to the RAM. It includes all the time from stable A and B addresses to the clock L → H transition, regardless of when the H → L transition occurs.
5. First value is direct path (DATA_{IN} → RAM/Q Register). Second value is indirect path (DATA_{IN} → ALU → RAM/Q Register).
6. Guaranteed by design, not production tested.



IDT49C402B

MAX. OUTPUT ENABLE/DISABLE TIMES

(CL = 5pF, measured to 0.5V change of V_{OUT} in nanoseconds)
Tested at CL = 50pF, correlated to 5pF

Input	Output	Enable		Disable	
		Mil.	Com'l.	Mil.	Com'l.
\overline{OE}	Y	18	16	15	13

2524 tbl 22

IDT49C402A

MAX. OUTPUT ENABLE/DISABLE TIMES

(CL = 5pF, measured to 0.5V change of V_{OUT} in nanoseconds)
Tested at CL = 50pF, correlated to 5pF

Input	Output	Enable		Disable	
		Mil.	Com'l.	Mil.	Com'l.
\overline{OE}	Y	22	20	20	18

2524 tbl 23

IDT49C402

MAX. OUTPUT ENABLE/DISABLE TIMES

(CL = 5pF, measured to 0.5V change of V_{OUT} in nanoseconds)
Tested at CL = 50pF, correlated to 5pF

Input	Output	Enable		Disable	
		Mil.	Com'l.	Mil.	Com'l.
\overline{OE}	Y	25	23	25	23

2524 tbl 24

CRITICAL SPEED PATH ANALYSIS

Critical speed paths for the IDT49C402B versus the equivalent bipolar circuit implementation using four 2901Cs and one 2902A are shown below.

The IDT49C402B operates faster than the theoretically achievable values of the discrete bipolar implementation. Actual speed values for the discrete bipolar circuit will increase due to on-chip/off-chip circuit board delays.

TIMING COMPARISON: IDT49C402B vs 2901C w/2902A

16-Bit μP System	Data Path (Com'l.)		Data Path (Mil.)		Unit
	AB ADDR → F = 0	AB ADDR → RAM _{0, 15}	AB ADDR → F = 0	AB ADDR → RAM _{0, 15}	
	Four 2901Cs + 2902A	≥ 71	≥ 71	≥ 83.5	
IDT49C402B	28	23	31	25	ns
Speed Savings	43	48	52	55	ns

2524 tbl 26

TIMING COMPARISON: IDT49C402A vs 2901C w/2902A

16-Bit μP System	Data Path (Com'l.)		Data Path (Mil.)		Unit
	AB ADDR → F = 0	AB ADDR → RAM _{0, 15}	AB ADDR → F = 0	AB ADDR → RAM _{0, 15}	
	Four 2901Cs + 2902A	≥ 71	≥ 71	≥ 83.5	
IDT49C402A	37	36	41	25	ns
Speed Savings	34	35	42.5	43.5	ns

2524 tbl 27

TIMING COMPARISON: IDT49C402 vs 2901C w/2902A

16-Bit μP System	Data Path (Com'l.)		Data Path (Mil.)		Unit
	AB ADDR → F = 0	AB ADDR → RAM _{0, 15}	AB ADDR → F = 0	AB ADDR → RAM _{0, 15}	
	Four 2901Cs + 2902A	≥ 71	≥ 71	≥ 83.5	
IDT49C402A	47	40	52	44	ns
Speed Savings	24	31	31.5	39.5	ns

2524 tbl 28

TEST CIRCUITS AND WAVEFORMS

TEST CIRCUITS FOR ALL OUTPUTS

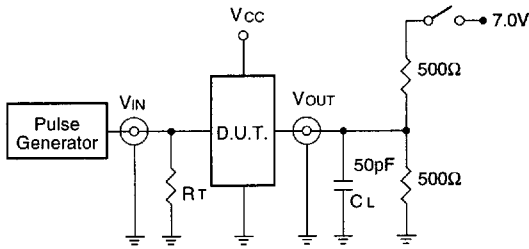

2524 drw 05

SWITCH POSITION

Test	Switch
Open Drain Disable Low Enable Low	Closed
All Other Tests	Open

DEFINITIONS:

CL = Load capacitance: includes jig and probe capacitance.
RT = Termination resistance: should be equal to Zout of the Pulse Generator.

2524 Ink 25

SET-UP, HOLD AND RELEASE TIMES

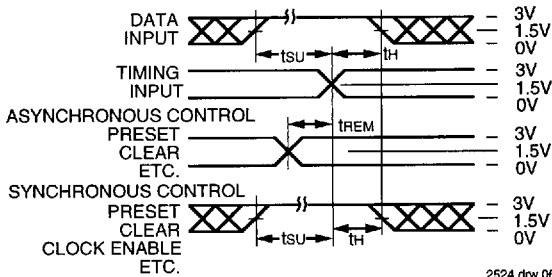

2524 drw 06

PULSE TIMES

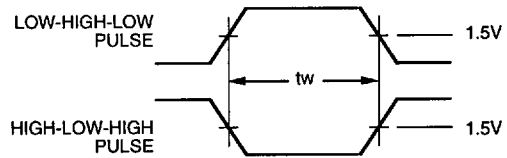

2524 drw 07

PROPAGATION DELAY

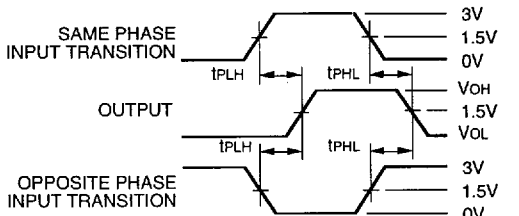

2524 drw 08

ENABLE AND DISABLE TIMES

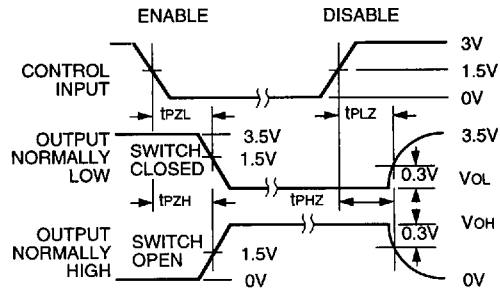

2524 drw 10

NOTES:

- Diagram shown for input Control Enable-LOW and input Control Disable-HIGH
- Pulse Generator for All Pulses: Rate ≤ 1.0MHz; tr ≤ 2.5ns; tr ≤ 2.5ns

ORDERING INFORMATION

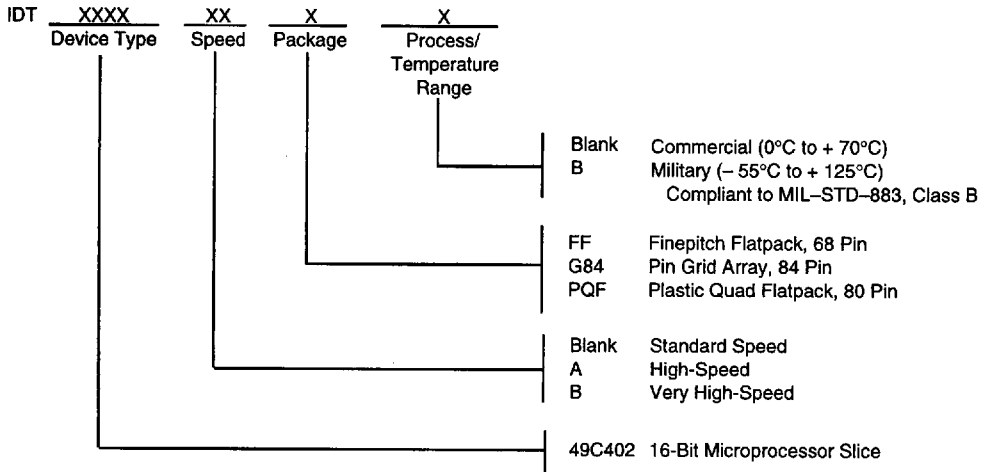

2524 drw 09