

REVISIONS

LTR	DESCRIPTION	DATE (YR-MO-DA)	APPROVED
A	Add footnote 5 to section 1.4. Add footnote 3 to table I. Add vendor CAGE number 34335, 6Y440. Add device type 06. Editorial changes throughout.	92-11-13	M.A. Frye
B	Changes in accordance with NOR 5962-R108-94	94-01-21	M.A. Frye
C	Changes in accordance with NOR 5962-R070-95	95-02-14	M.A. Frye
D	Updated boilerplate. Add device type 07. Add vendor CAGE number 0HGZ7.	97-02-25	Ray Monnin
E	Boilerplate update, part of 5 year review. ksr	07-10-22	Robert Heber
F	Update boilerplate to reflect current MIL-PRF-38535 requirements. - llb	16-02-01	Charles F. Saffle



THE ORIGINAL FIRST PAGE OF THIS DRAWING HAS BEEN REPLACED.

REV																				
SHEET																				
REV	F	F	F	F	F	F	F	F	F											
SHEET	15	16	17	18	19	20	21	22	23											
REV STATUS OF SHEETS	REV			F	F	F	F	F	F	F	F	F	F	F	F	F	F	F	F	
	SHEET			1	2	3	4	5	6	7	8	9	10	11	12	13	14			
PMIC N/A	PREPARED BY Rick Officer									DLA LAND AND MARITIME COLUMBUS, OHIO 43218-3990 http://www.landandmaritime.dla.mil										
STANDARD MICROCIRCUIT DRAWING THIS DRAWING IS AVAILABLE FOR USE BY ALL DEPARTMENTS AND AGENCIES OF THE DEPARTMENT OF DEFENSE AMSC N/A	CHECKED BY Ray Monnin																			
	APPROVED BY Michael A. Frye									MICROCIRCUIT, DIGITAL, CMOS, 2K X 9 FIRST-IN, FIRST-OUT (FIFO), MONOLITHIC SILICON										
	DRAWING APPROVAL DATE 89-02-10																			
	REVISION LEVEL F									SIZE A	CAGE CODE 67268	5962-88669								
										SHEET 1 OF 23										

1. SCOPE

1.1 Scope. This drawing describes device requirements for MIL-STD-883 compliant, non-JAN class level B microcircuits in accordance with MIL-PRF-38535, appendix A.

1.2 Part or Identifying Number (PIN). The complete PIN is as shown in the following example:

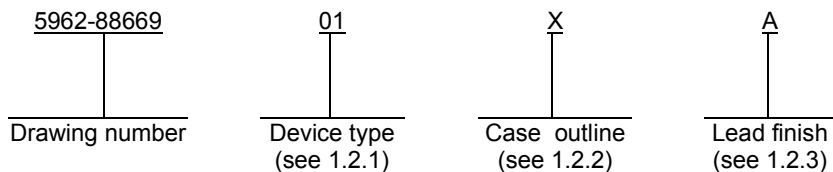

1.2.1 Device types. The device types identify the circuit function as follows:

<u>Device type</u>	<u>Generic number 1/</u>	<u>Circuit function</u>	<u>Access time</u>
01		2048 X 9 FIFO	80 ns
02		2048 X 9 FIFO	65 ns
03		2048 X 9 FIFO	50 ns
04		2048 X 9 FIFO	40 ns
05		2048 X 9 FIFO	30 ns
06		2048 X 9 FIFO	20 ns
07		2048 X 9 FIFO	25 ns

1.2.2 Case outline(s). The case outline(s) are as designated in MIL-STD-1835 and as follows:

<u>Outline letter</u>	<u>Descriptive designator</u>	<u>Terminals</u>	<u>Package style</u>
X	GDIP1-T28 or CDIP2-T28	28	Dual-in-line package
Y	CDIP3-T28 or GDIP4-T28	28	Dual-in-line package
Z	CQCC1-N32	32	Rectangular leadless chip carrier
U	GDFP2-F28	28	Flat package

1.2.3 Lead finish. The lead finish is as specified in MIL-PRF-38535, appendix A.

1.3 Absolute maximum ratings.

Supply voltage range	-0.5 V dc to +7.0 V dc
DC voltage applied to outputs in high-Z state	-0.5 V dc to +7.0 V dc
DC input voltage range	-0.5 V dc to +7.0 V dc <u>2/</u>
DC output current	20 mA
Maximum power dissipation <u>3/</u>	1.0 W
Lead temperature (soldering, 10 seconds)	+260°C
Thermal resistance, junction-to-case (Θ_{JC}):	See MIL-STD-1835
Junction temperature (T_J) <u>4/</u>	+150°C
Storage temperature range	-65°C to +150°C
Temperature under bias	-55°C to +125°C

- 1/ Generic numbers are listed on the Standard Microcircuit Source Approval Bulletin at the end of this document and will also be listed in MIL-HDBK-103.
- 2/ 1.5 V undershoots are allowed for 10 ns once per cycle.
- 3/ Must withstand the added P_D due to short circuit test (e.g., I_{OS}).
- 4/ Maximum junction temperature may be increased to +175°C during burn-in and steady-state life.

STANDARD MICROCIRCUIT DRAWING DLA LAND AND MARITIME COLUMBUS, OHIO 43218-3990	SIZE A		5962-88669
		REVISION LEVEL F	SHEET 2

1.4 Recommended operating conditions.

Supply voltage range (V_{CC})	+4.5 V dc to +5.5 V dc
Ground voltage (GND)	0 V dc
Input high voltage (V_{IH})	2.2 V dc minimum <u>5/</u>
Input low voltage (V_{IL})	0.8 V dc maximum
Case operating temperature range (T_C)	-55°C to +125°C

2. APPLICABLE DOCUMENTS

2.1 Government specification, standards, and handbooks. The following specification, standards, and handbooks form a part of this drawing to the extent specified herein. Unless otherwise specified, the issues of these documents are those cited in the solicitation or contract.

DEPARTMENT OF DEFENSE SPECIFICATION

MIL-PRF-38535 - Integrated Circuits, Manufacturing, General Specification for.

DEPARTMENT OF DEFENSE STANDARDS

MIL-STD-883 - Test Method Standard Microcircuits.
 MIL-STD-1835 - Interface Standard Electronic Component Case Outlines.

DEPARTMENT OF DEFENSE HANDBOOKS

MIL-HDBK-103 - List of Standard Microcircuit Drawings.
 MIL-HDBK-780 - Standard Microcircuit Drawings.

(Copies of these documents are available online at <http://quicksearch.dla.mil> or from the Standardization Document Order Desk, 700 Robbins Avenue, Building 4D, Philadelphia, PA 19111-5094).

2.2 Order of precedence. In the event of a conflict between the text of this drawing and the references cited herein, the text of this drawing takes precedence. Nothing in this document, however, supersedes applicable laws and regulations unless a specific exemption has been obtained.

3. REQUIREMENTS

3.1 Item requirements. The individual item requirements shall be in accordance with MIL-PRF-38535, appendix A for non-JAN class level B devices and as specified herein. Product built to this drawing that is produced by a Qualified Manufacturer Listing (QML) certified and qualified manufacturer or a manufacturer who has been granted transitional certification to MIL-PRF-38535 may be processed as QML product in accordance with the manufacturers approved program plan and qualifying activity approval in accordance with MIL-PRF-38535. This QML flow as documented in the Quality Management (QM) plan may make modifications to the requirements herein. These modifications shall not affect form, fit, or function of the device. These modifications shall not affect the PIN as described herein. A "Q" or "QML" certification mark in accordance with MIL-PRF-38535 is required to identify when the QML flow option is used. This drawing has been modified to allow the manufacturer to use the alternate die/fabrication requirements of paragraph A.3.2.2 of MIL-PRF-38535 or other alternative approved by the qualifying activity.

3.2 Design, construction, and physical dimensions. The design, construction, and physical dimensions shall be as specified in MIL-PRF-38535, appendix A and herein.

3.2.1 Case outlines. The case outlines shall be in accordance with 1.2.2 herein.

3.2.2 Terminal connections. The terminal connections shall be as specified on figure 1.

3.2.3 Truth table. The truth table shall be as specified on figure 2.

5/ V_{IH} is 2.2 V minimum for all input pins except $\bar{X}I$, which is 3.5 V minimum.

STANDARD MICROCIRCUIT DRAWING DLA LAND AND MARITIME COLUMBUS, OHIO 43218-3990	SIZE A		5962-88669
		REVISION LEVEL F	SHEET 3

3.2.4 Die overcoat. Polyimide and silicone coatings are allowable as an overcoat on the die for alpha particle protection provided that each coated microcircuit inspection lot (reference appendix A of MIL-PRF-38535, 30.1.3.8) shall be subjected to and pass the internal moisture content test, (test method 1018 of MIL-STD-883), the frequency of the internal water vapor testing may not be decreased unless approved by the preparing activity.

3.3 Electrical performance characteristics. Unless otherwise specified herein, the electrical performance characteristics are as specified in table I and shall apply over the full case operating temperature range.

3.4 Electrical test requirements. The electrical test requirements shall be the subgroups specified in table II. The electrical tests for each subgroup are described in table I.

3.5 Marking. Marking shall be in accordance with MIL-PRF-38535, appendix A. The part shall be marked with the PIN listed in 1.2 herein. In addition, the manufacturer's PIN may also be marked. For packages where marking of the entire SMD PIN number is not feasible due to space limitations, the manufacturer has the option of not marking the "5962-" on the device.

3.5.1 Certification/compliance mark. A compliance indicator "C" shall be marked on all non-JAN devices built in compliance to MIL-PRF-38535, appendix A. The compliance indicator "C" shall be replaced with a "Q" or "QML" certification mark in accordance with MIL-PRF-38535 to identify when the QML flow option is used. For product built in accordance with A.3.2.2 of MIL-PRF-38535, or as modified in the manufacturer's QM plan, the "QD" certification mark shall be used in place of the "Q" or "QML" certification mark.

3.6 Certificate of compliance. A certificate of compliance shall be required from a manufacturer in order to be listed as an approved source of supply in MIL-HDBK-103 (see 6.6 herein). The certificate of compliance submitted to DLA Land and Maritime-VA prior to listing as an approved source of supply shall affirm that the manufacturer's product meets the requirements of MIL-PRF-38535, appendix A and the requirements herein.

3.7 Certificate of conformance. A certificate of conformance as required in MIL-PRF-38535, appendix A shall be provided with each lot of microcircuits delivered to this drawing.

3.8 Notification of change. Notification of change to DLA Land and Maritime-VA shall be required for any change that affects this drawing.

3.9 Verification and review. DLA Land and Maritime, DLA Land and Maritime's agent, and the acquiring activity retain the option to review the manufacturer's facility and applicable required documentation. Offshore documentation shall be made available onshore at the option of the reviewer.

STANDARD MICROCIRCUIT DRAWING DLA LAND AND MARITIME COLUMBUS, OHIO 43218-3990	SIZE A		5962-88669
		REVISION LEVEL F	SHEET 4

TABLE I. Electrical performance characteristics.

Test	Symbol	Conditions 1/ -55°C ≤ T _C ≤ +125°C 4.5 V ≤ V _{CC} ≤ 5.5 V unless otherwise specified	Group A subgroups	Device type	Limits		Unit
					Min	Max	
Output high voltage	V _{OH}	V _{CC} = 4.5, I _{OH} = -2.0 mA, V _{IN} = V _{IL} , V _{IH}	1, 2, 3	All	2.4		V
Output low voltage	V _{OL}	V _{CC} = 4.5 V, I _{OL} = 8.0 mA, V _{IN} = V _{IL} , V _{IH}	1, 2, 3	All		0.4	V
Input high voltage	V _{IH} 2/ 3/		1, 2, 3	All	2.2		V
Input low voltage	V _{IL} 2/		1, 2, 3	All	4/ -0.5	0.8	V
Input leakage current	I _{IX}	V _{IN} = 5.5 V to GND	1, 2, 3	All	-10	10	μA
Output leakage current	I _{OZ}	V _{CC} = 5.5 V, V _{OUT} = 5.5 V and GND	1, 2, 3	All	-10	10	μA
Operating supply current	I _{CC}	V _{CC} = 5.5 V, I _{OUT} = 0mA f = 1/t _{RC} W, R, D ₀ – D ₈ pins are toggling between 0 V and 3 V FF, X _O /HF = 0 mA Q ₀ – Q ₈ = 0 mA MR, FL/RT = 3.0 V	1, 2, 3	All		150	mA
Standby current	I _{SB1}	V _{CC} = 5.5 V, I _{OUT} = 0mA All inputs = V _{IH} FF, X _O /HF = 0 mA Q ₀ – Q ₈ = 0 mA	1, 2, 3	All		30	mA
Power down current	I _{SB2}	V _{CC} = 5.5 V, I _{OUT} = 0 mA All inputs = V _{CC} - 0.2 V FF, X _O /HF = 0 mA Q ₀ – Q ₈ = 0 mA	1, 2, 3	All		25	mA
Input capacitance	C _{IN}	V _{IN} = 0 V, V _{CC} = 5.0 V T _A = +25°C, f = 1 MHz (See 4.3.1c)	4	All		8	pF
Output capacitance	C _{OUT}	V _O = 0 V, V _{CC} = 5.0 V T _A = +25°C, f = 1 MHz (See 4.3.1c)	4	All		12	pF

See footnotes at end of table.

**STANDARD
MICROCIRCUIT DRAWING**
DLA LAND AND MARITIME
COLUMBUS, OHIO 43218-3990

SIZE
A

5962-88669

REVISION LEVEL
F

SHEET

5

TABLE I. Electrical performance characteristics – Continued.

Test	Symbol	Conditions <u>1/</u> -55°C ≤ T _C ≤ +125°C 4.5 V ≤ V _{CC} ≤ 5.5 V unless otherwise specified	Group A subgroups	Device type	Limits		Unit
					Min	Max	
Read cycle time	t _{RC}		9, 10, 11	01	100		ns
				02	80		
				03	65		
				04	50		
				05	40		
				06	30		
				07	35		
Access time	t _A		9, 10, 11	01		85	ns
				02		65	
				03		50	
				04		40	
				05		30	
				06		20	
				07		25	
Read recovery time	t _{RR}		9, 10, 11	01	20		ns
				02, 03	15		
				04-07	10		
Read pulse width	t _{PR}		9, 10, 11	01	80		ns
				02	65		
				03	50		
				04	40		
				05	30		
				06	20		
				07	25		
Read low to low-Z	t _{LZR} <u>5/ 6/</u>		9, 10, 11	All	3		ns
Read high to data valid	t _{DVR}		9, 10, 11	01-06	3		ns
				07	5		

See footnotes at end of table.

**STANDARD
MICROCIRCUIT DRAWING**
DLA LAND AND MARITIME
COLUMBUS, OHIO 43218-3990

SIZE
A

5962-88669

REVISION LEVEL
F

SHEET
6

TABLE I. Electrical performance characteristics – Continued.

Test	Symbol	Conditions <u>1/</u> -55°C ≤ T _C ≤ +125°C 4.5 V ≤ V _{CC} ≤ 5.5 V unless otherwise specified	Group A subgroup s	Device type	Limits		Unit
					Min	Max	
Read high to high-Z	t _{HZR} <u>5/ 6/</u>		9, 10, 11	01, 02,03		30	ns
				04		25	
				05		20	
				06		15	
				07		18	
Write cycle time	t _{wc}		9, 10, 11	01	100		ns
				02	80		
				03	65		
				04	50		
				05	40		
				06	30		
				07	35		
Write pulse width	t _{pw}		9, 10, 11	01	80		ns
				02	65		
				03	50		
				04	40		
				05	30		
				06	20		
				07	25		
Write high to low-Z	t _{HWZ} <u>5/ 6/</u>		9, 10, 11	01-04	10		ns
				05-07	5		
Write recovery time	t _{wr}		9, 10, 11	01	20		ns
				02,03	15		
				04-07	10		
Data setup time	t _{sd}		9, 10, 11	01	40		ns
				02,03	30		
				04	20		
				05	18		
				06	12		
				07	15		

See footnotes at end of table.

STANDARD MICROCIRCUIT DRAWING DLA LAND AND MARITIME COLUMBUS, OHIO 43218-3990	SIZE A		5962-88669
		REVISION LEVEL F	SHEET 7

TABLE I. Electrical performance characteristics - Continued.

Test	Symbol	Conditions 1/ -55°C ≤ T _C ≤ +125°C 4.5 V ≤ V _{CC} ≤ 5.5 V unless otherwise specified	Group A subgroups	Device type	Limits		Unit
					Min	Max	
Data hold time	t _{HD}		9, 10, 11	01,02	10		ns
				03	5		
				04-07	0		
Master reset cycle time	t _{MRSC}		9, 10, 11	01	100		ns
				02	80		
				03	65		
				04	50		
				05	40		
				06	30		
				07	35		
Master reset pulse width	t _{PMR}		9, 10, 11	01	80		ns
				02	65		
				03	50		
				04	40		
				05	30		
				06	20		
				07	25		
Master reset recovery time	t _{RMR}		9, 10, 11	01	20		ns
				02,03	15		
				04-07	10		
Read high to master reset high	t _{RPW}		9, 10, 11	01	80		ns
				02	65		
				03	50		
				04	40		
				05	30		
				06	20		
				07	25		

See footnotes at end of table.

STANDARD MICROCIRCUIT DRAWING DLA LAND AND MARITIME COLUMBUS, OHIO 43218-3990	SIZE A		5962-88669
		REVISION LEVEL F	SHEET 8

TABLE I. Electrical performance characteristics - Continued.

Test	Symbol	Conditions 1/ -55°C ≤ T _C ≤ +125°C 4.5 V ≤ V _{CC} ≤ 5.5 V unless otherwise specified	Group A subgroups	Device type	Limits		Unit
					Min	Max	
Write high to master reset high	t _{WPW}		9, 10, 11	01	80		ns
				02	65		
				03	50		
				04	40		
				05	30		
				06	20		
				07	25		
Retransmit cycle time	t _{RTC}		9, 10, 11	01	100		ns
				02	80		
				03	65		
				04	50		
				05	40		
				06	45		
				07	35		
Retransmit pulse width	t _{PRT}		9, 10, 11	01	80		ns
				02	65		
				03	50		
				04	40		
				05	30		
				06	35		
				07	25		
Retransmit recovery time	t _{RTR}		9, 10, 11	01	20		ns
				02,03	15		
				04-07	10		
Master reset to empty flag low	t _{EFL}		9, 10, 11	01		100	ns
				02		80	
				03		65	
				04		50	
				05		40	
				06		30	
				07		35	

See footnotes at end of table.

STANDARD MICROCIRCUIT DRAWING DLA LAND AND MARITIME COLUMBUS, OHIO 43218-3990	SIZE A		5962-88669
		REVISION LEVEL F	SHEET 9

TABLE I. Electrical performance characteristics – Continued.

Test	Symbol	Conditions 1/ -55°C ≤ T _C ≤ +125°C 4.5 V ≤ V _{CC} ≤ 5.5 V unless otherwise specified	Group A subgroups	Device type	Limits		Unit
					Min	Max	
Master reset to half-full flag high	t _{HFH}		9, 10, 11	01		100	ns
				02		80	
				03		65	
				04		50	
				05		40	
				06		30	
				07		35	
Master reset to full flag high	t _{FFH}		9, 10, 11	01		100	ns
				02		80	
				03		65	
				04		50	
				05		40	
				06		30	
				07		35	
Read low to empty flag low	t _{REF}		9, 10, 11	01,02		60	ns
				03		45	
				04		35	
				05		30	
				06		28	
				07		25	
Read high to full flag high	t _{RFF}		9, 10, 11	01,02		60	ns
				03		45	
				04		35	
				05		30	
				06		28	
				07		25	
Write high to empty flag high	t _{WEF}		9, 10, 11	01,02		60	ns
				03		45	
				04		25	
				05		30	
				06		28	
				07		25	

See footnotes at end of table.

STANDARD MICROCIRCUIT DRAWING DLA LAND AND MARITIME COLUMBUS, OHIO 43218-3990	SIZE A		5962-88669
		REVISION LEVEL F	SHEET 10

TABLE I. Electrical performance characteristics – Continued.

Test	Symbol	Conditions <u>1/</u> -55°C ≤ T _C ≤ +125°C 4.5 V ≤ V _{CC} ≤ 5.5 V unless otherwise specified	Group A subgroups	Device type	Limits		Unit
					Min	Max	
Write low to full flag low	t _{WFF}		9, 10, 11	01,02		60	ns
				03		45	
				04		35	
				05		30	
				06		28	
				07		25	
Write low to half-full flag low	t _{WHF}		9, 10, 11	01		100	ns
				02		80	
				03		65	
				04		50	
				05		40	
				06		30	
				07		25	
Read high to half-full flag high	t _{RHF}		9, 10, 11	01		100	ns
				02		80	
				03		65	
				04		50	
				05		40	
				06		30	
				07		25	
Effective read from write high	t _{RAE} <u>4/</u>		9, 10, 11	01		60	ns
				02		60	
				03		45	
				04		35	
				05		30	
				06		20	
				07		25	

See footnotes at end of table.

STANDARD MICROCIRCUIT DRAWING DLA LAND AND MARITIME COLUMBUS, OHIO 43218-3990	SIZE A		5962-88669
		REVISION LEVEL F	SHEET 11

TABLE I. Electrical performance characteristics - Continued.

Test	Symbol	Conditions 1/ -55°C ≤ T _C ≤ +125°C 4.5 V ≤ V _{CC} ≤ 5.5 V unless otherwise specified	Group A subgroups	Device type	Limits		Unit
					Min	Max	
Effective read pulse width after empty	t _{RPE}		9, 10, 11	01	80		ns
				02	65		
				03	50		
				04	40		
				05	30		
				06	20		
				07	25		
Effective write from read high	t _{WAF} 4/		9, 10, 11	01		60	ns
				02		60	
				03		45	
				04		35	
				05		30	
				06		20	
				07		25	
Effective write pulse width after full flag high	t _{WPF}		9, 10, 11	01	80		ns
				02	65		
				03	50		
				04	40		
				05	30		
				06	20		
				07	25		
Expansion out low delay from clock	t _{XOL} 5/		9, 10, 11	01		80	ns
				02		65	
				03		50	
				04		40	
				05		30	
				06		20	
				07		25	

See footnotes at end of table.

STANDARD MICROCIRCUIT DRAWING DLA LAND AND MARITIME COLUMBUS, OHIO 43218-3990	SIZE A		5962-88669
		REVISION LEVEL F	SHEET 12

TABLE I. Electrical performance characteristics – Continued.

Test	Symbol	Conditions <u>1/</u> -55°C ≤ T _C ≤ +125°C 4.5 V ≤ V _{CC} ≤ 5.5 V unless otherwise specified	Group A subgroups	Device type	Limits		Unit
					Min	Max	
Expansion out high delay from clock	t _{XOH} <u>5/</u>		9, 10, 11	01		80	ns
				02		65	
				03		50	
				04		40	
				05		30	
				06		20	
				07		25	

- 1/ AC tests are performed with input rise and fall times of 5 ns or less, timing reference levels of 1.5 V, input pulse levels of 0 to 3.0 V, and the output load circuit, unless otherwise specified. See figures 4 and 5.
AC tests are performed with input rise and fall times of 5 ns or less, timing reference levels of 1.5 V, input pulse levels of 0 to 3.0 V, and the output load circuit, unless otherwise specified. See figures 4 and 5.
- 2/ These are absolute values with respect to device ground and all overshoots due to system or tester noise are included.
- 3/ V_{IH} is 2.2 V minimum for all input pins except XI, which is 3.5 V minimum.
- 4/ May not be tested, but shall be guaranteed to the limits specified in table I herein.
- 5/ Tested initially and after any design or process changes that affect that parameter, and therefore shall be guaranteed to the limits specified in table I.
- 6/ Transition is measured at steady-state high level -500 mV or steady-state low level +500 mV on the output from the 1.5 V level on the input.

**STANDARD
MICROCIRCUIT DRAWING**
DLA LAND AND MARITIME
COLUMBUS, OHIO 43218-3990

SIZE
A

5962-88669

REVISION LEVEL
F

SHEET
13

Device types	01-07	
Case outlines	X, Y, and U	Z
Terminal number	Terminal symbol	Terminal symbol
1	W	NC
2	D ₈	W
3	D ₃	D ₈
4	D ₂	D ₃
5	D ₁	D ₂
6	D ₀	D ₁
7	XI	D ₀
8	FF	XI
9	Q ₀	FF
10	Q ₁	Q ₀
11	Q ₂	Q ₁
12	Q ₃	NC
13	Q ₈	Q ₂
14	GND	Q ₃
15	R	Q ₈
16	Q ₄	GND
17	Q ₅	NC
18	Q ₆	R
19	Q ₇	Q ₄
20	XO/HF	Q ₅
21	EF	Q ₆
22	MR	Q ₇
23	FL/RT	XO/HF
24	D ₇	EF
25	D ₆	MR
26	D ₅	FL/RT
27	D ₄	NC
28	V _{CC}	D ₇
29	---	D ₆
30	---	D ₅
31	---	D ₄
32	---	V _{CC}

NC = no connection

FIGURE 1. Terminal connections.

STANDARD MICROCIRCUIT DRAWING DLA LAND AND MARITIME COLUMBUS, OHIO 43218-3990	SIZE A		5962-88669
		REVISION LEVEL F	SHEET 14

Reset and retransmit
Single device configuration/width expansion mode

Mode	Inputs			Internal status		Outputs		
	\overline{MR}	\overline{RT}	\overline{XI}	Read pointer	Write pointer	\overline{EF}	\overline{FF}	\overline{HF}
Reset	0	X	0	Location zero	Location zero	0	1	1
Retransmit	1	0	0	Location zero	Unchanged	X	X	X
Read/write	1	1	0	Increment	Increment (see note 2)	X	X	X

Reset and first load truth table
Depth expansion/compound expansion mode

Mode	Inputs			Internal status		Outputs	
	\overline{MR}	\overline{FL}	\overline{XI}	Read pointer	Write pointer	\overline{EF}	\overline{FF}
Reset first device	0	0	(see note 3)	Location zero	Location zero	0	1
Reset all other devices	0	1	(see note 3)	Location zero	Location zero	X	X
Read/write	1	X	(see note 3)	X	X	X	X

NOTES:

1. \overline{MR} = Reset input, $\overline{FL}/\overline{RT}$ = First load/retransmit \overline{EF} = Empty flag output, \overline{FF} = Full flag output, \overline{XI} = Expansion input, and \overline{HF} = Half-full flag output
2. Pointer will increment if flag is high.
3. \overline{XI} is connected to \overline{XO} of previous device.

FIGURE 2. Truth tables.

**STANDARD
MICROCIRCUIT DRAWING**
DLA LAND AND MARITIME
COLUMBUS, OHIO 43218-3990

SIZE
A

5962-88669

REVISION LEVEL
F

SHEET
15

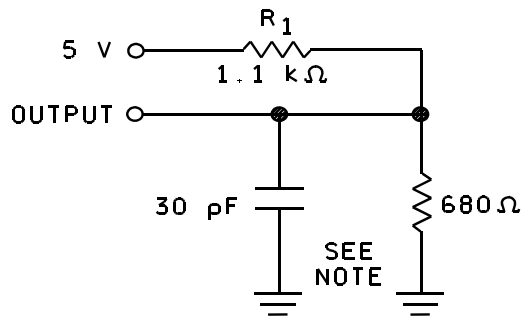

NOTE: 30 pF includes scope and jig capacitance.

FIGURE 3. Output load circuit.

Asynchronous read and write diagram.

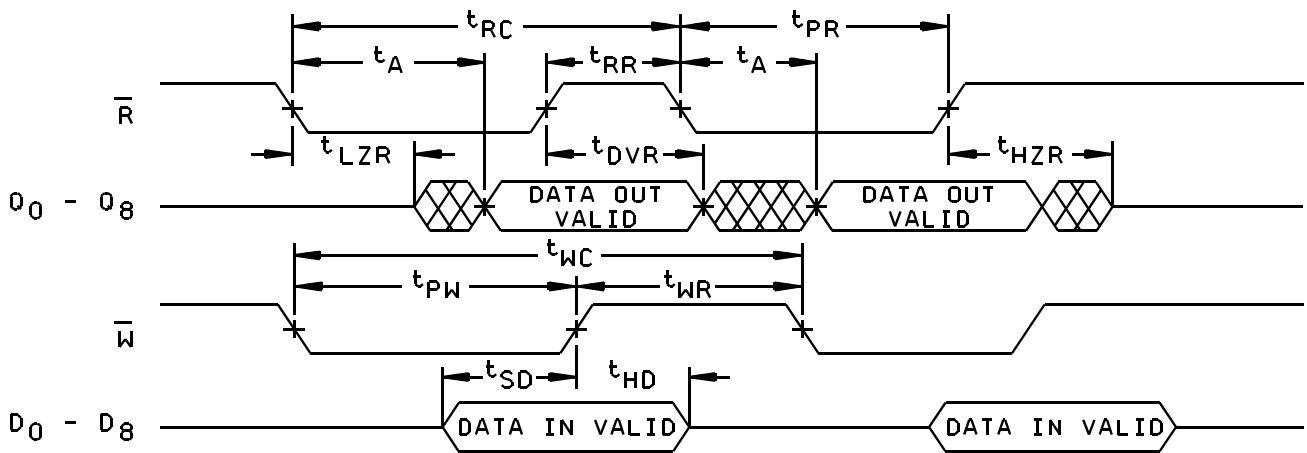

FIGURE 4. Timing waveforms.

**STANDARD
MICROCIRCUIT DRAWING**
DLA LAND AND MARITIME
COLUMBUS, OHIO 43218-3990

SIZE
A

5962-88669

REVISION LEVEL
F

SHEET
16

Last read to first write empty flag timing diagram

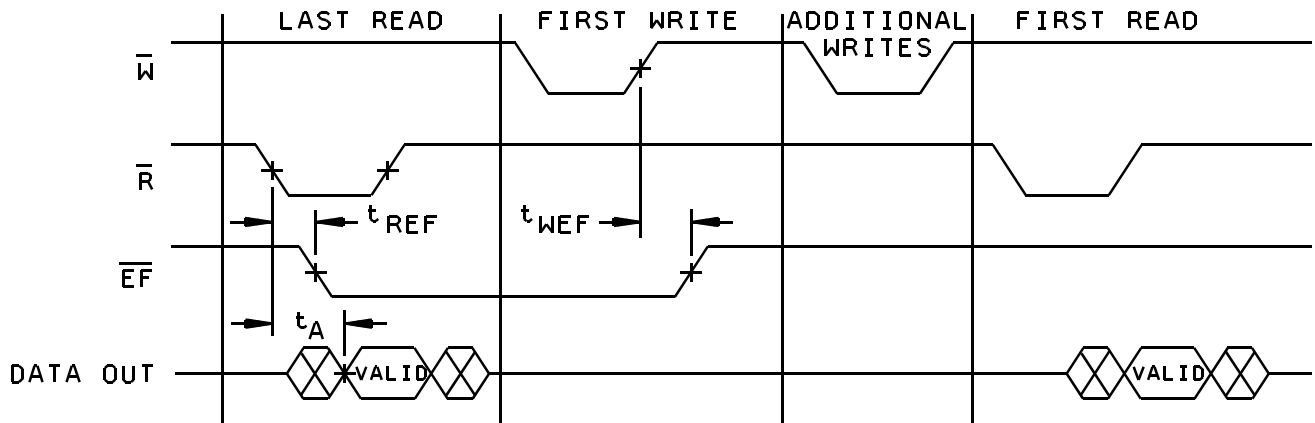

Retransmit timing diagram

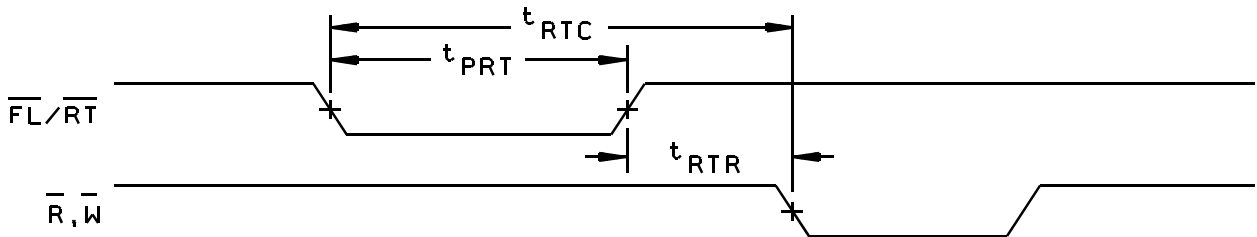

NOTES:

1. $t_{RTC} = t_{RT} + t_{RTR}$.
2. \overline{EF} , \overline{HF} and \overline{FF} may change state during retransmit as a result of the offset of the read and write pointers, but flags will be valid at t_{RTC} .

FIGURE 4. Timing waveforms - Continued.

**STANDARD
MICROCIRCUIT DRAWING**
DLA LAND AND MARITIME
COLUMBUS, OHIO 43218-3990

SIZE
A

5962-88669

REVISION LEVEL
F

SHEET
17

Empty flag and read bubble-through mode timing diagram

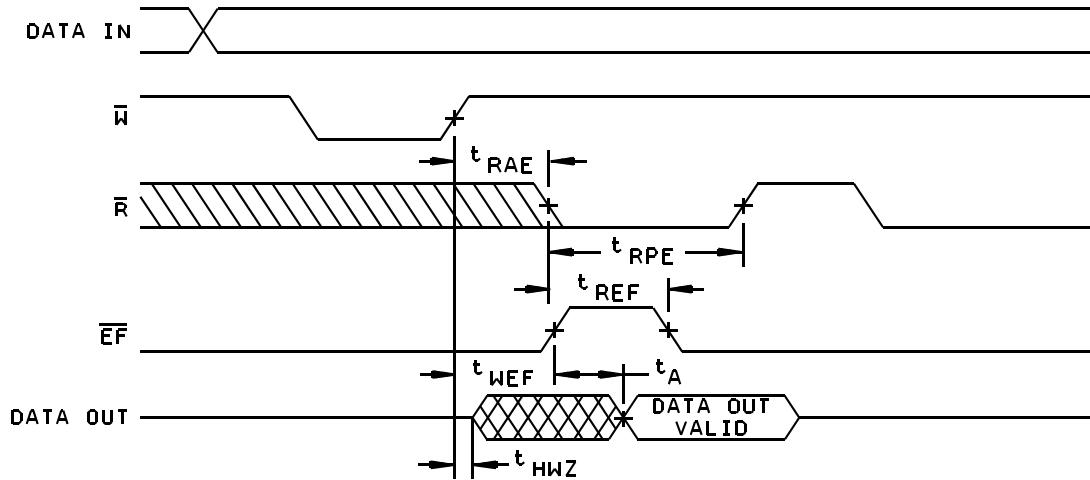

Master reset timing diagram

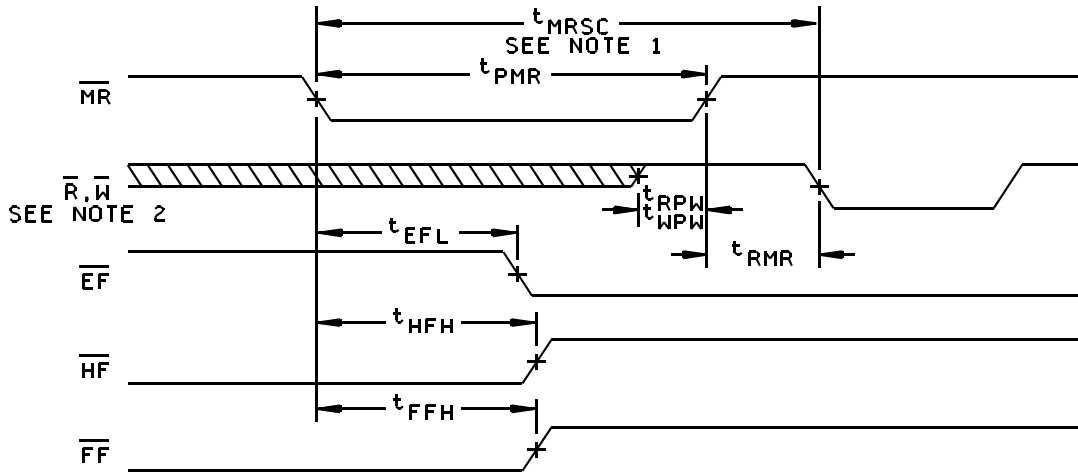

NOTES:

1. $t_{MRSC} = t_{PMR} + t_{RMR}$.

2. \overline{W} and $\overline{R} = V_{IH}$ around the rising edge of \overline{MR} .

FIGURE 4. Timing waveforms - Continued.

**STANDARD
MICROCIRCUIT DRAWING**
DLA LAND AND MARITIME
COLUMBUS, OHIO 43218-3990

SIZE
A

5962-88669

REVISION LEVEL
F

SHEET
18

Half-full flag timing diagram

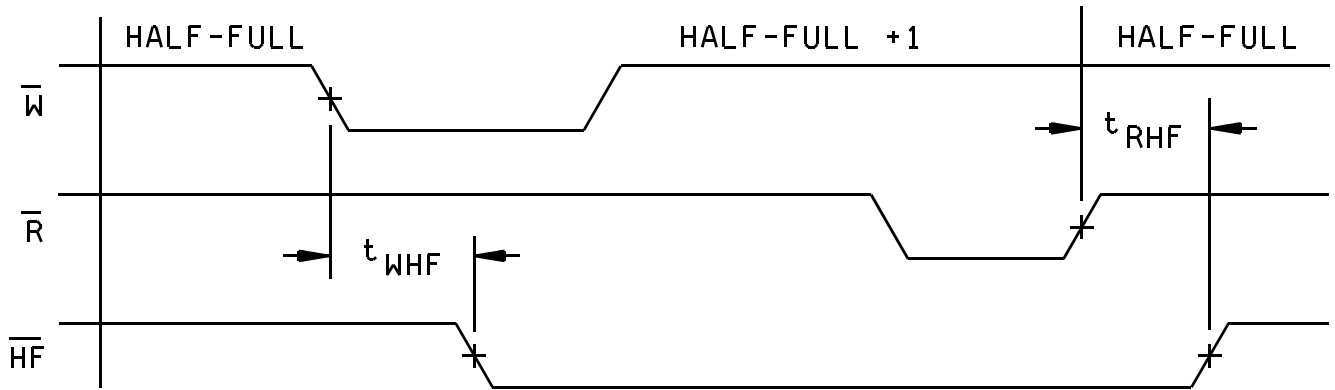

Last write to first read full flag timing diagram

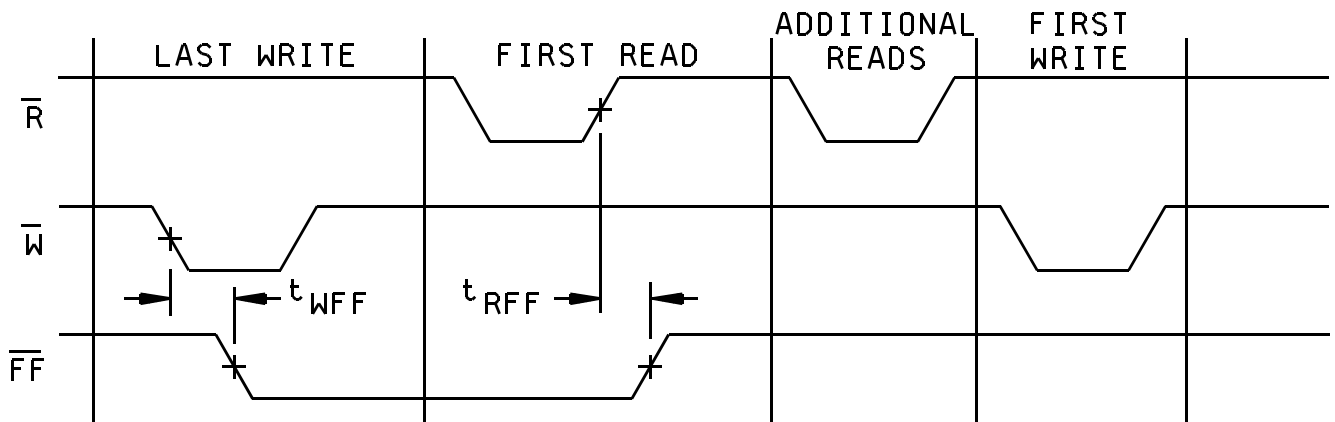

FIGURE 4. Timing waveforms - Continued.

**STANDARD
MICROCIRCUIT DRAWING**
DLA LAND AND MARITIME
COLUMBUS, OHIO 43218-3990

SIZE
A

5962-88669

REVISION LEVEL
F

SHEET
19

Full flag and write bubble-through mode timing diagram

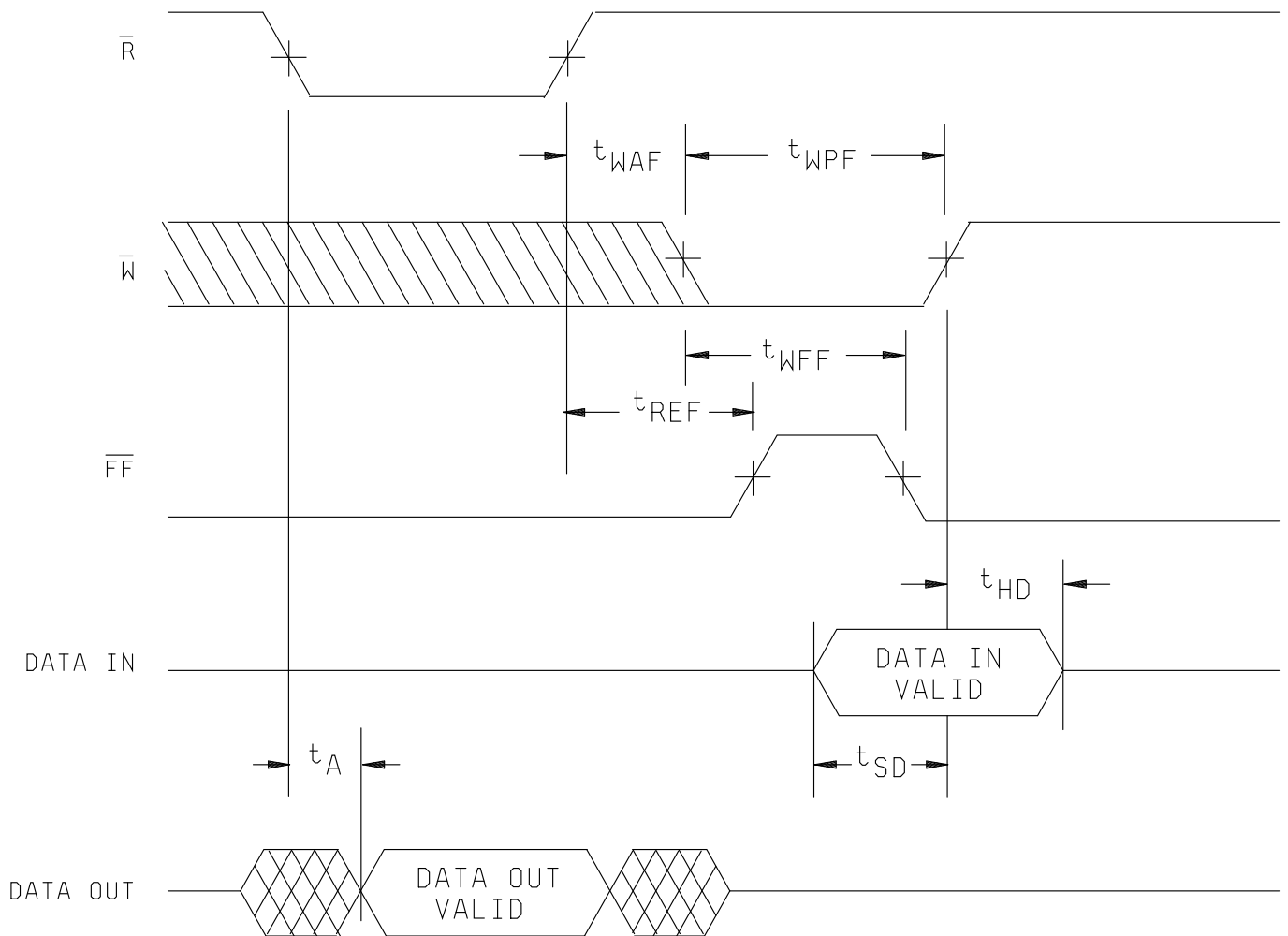

FIGURE 4. Timing waveforms - Continued.

**STANDARD
MICROCIRCUIT DRAWING**
DLA LAND AND MARITIME
COLUMBUS, OHIO 43218-3990

SIZE
A

5962-88669

REVISION LEVEL
F

SHEET
20

Expansion timing diagrams

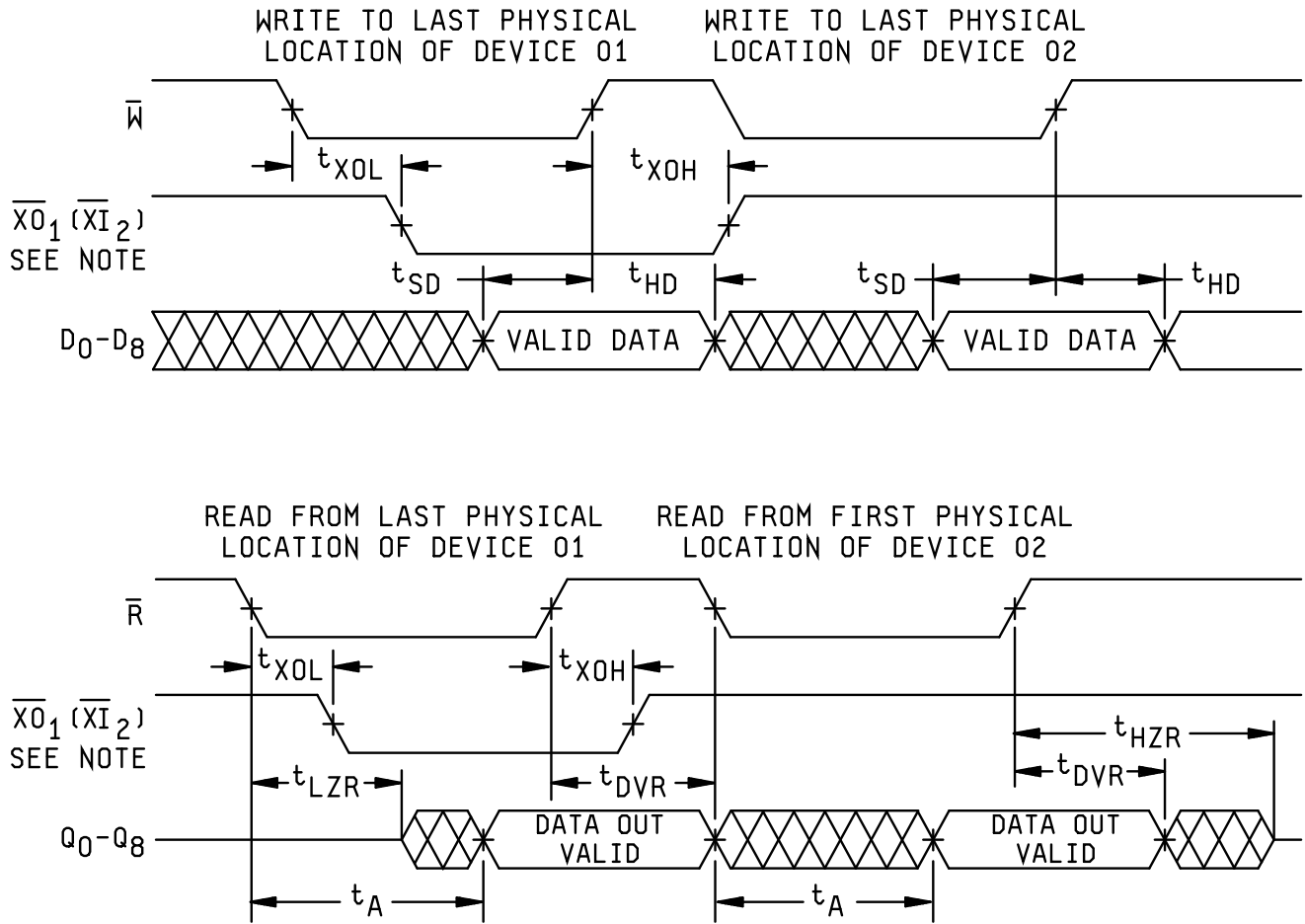

Note: Expansion out of device 1 (\overline{XO}_1) is connected to expansion in for device 2 (\overline{XI}_2).

FIGURE 4. Timing waveforms - Continued.

STANDARD MICROCIRCUIT DRAWING DLA LAND AND MARITIME COLUMBUS, OHIO 43218-3990	SIZE A		5962-88669
		REVISION LEVEL F	SHEET 21

4. VERIFICATION

4.1 Sampling and inspection. Sampling and inspection procedures shall be in accordance with MIL-PRF-38535, appendix A.

4.2 Screening. Screening shall be in accordance with method 5004 of MIL-STD-883, and shall be conducted on all devices prior to quality conformance inspection. The following additional criteria shall apply:

a. Burn-in test, method 1015 of MIL-STD-883.

(1) Test condition C or D. The test circuit shall be maintained by the manufacturer under document revision level control and shall be made available to the preparing or acquiring activity upon request. The test circuit shall specify the inputs, outputs, biases, and power dissipation, as applicable, in accordance with the intent specified in method 1015 of MIL-STD-883.

(2) $T_A = +125^\circ\text{C}$, minimum.

b. Interim and final electrical test parameters shall be as specified in table II herein, except interim electrical parameter tests prior to burn-in are optional at the discretion of the manufacturer.

TABLE II. Electrical test requirements.

MIL-STD-883 test requirements	Subgroups (in accordance with MIL-STD-883, method 5005, table I)
Interim electrical parameters (method 5004)	---
Final electrical test parameters (method 5004)	1*, 2, 3, 7*, 8A, 8B, 9, 10, 11
Group A test requirements (method 5005)	1, 2, 3, 4**, 7, 8A, 8B, 9, 10, 11
Groups C and D end-point electrical parameters (method 5005)	2, 3, 7, 8A, 8B

* PDA applies to subgroup 1.

4.3 Quality conformance inspection. Quality conformance inspection shall be in accordance with method 5005 of MIL-STD-883 including groups A, B, C, and D inspections. The following additional criteria shall apply.

4.3.1 Group A inspection.

a. Tests shall be as specified in table II herein.

b. Subgroups 5 and 6 in table I, method 5005 of MIL-STD-883 shall be omitted.

c. Subgroup 4 (C_{IN} and C_{OUT} measurement) shall be measured only for the initial test and after process or design changes which may affect input capacitance.

d. Subgroups 7 and 8 shall include verification of the truth table.

STANDARD MICROCIRCUIT DRAWING DLA LAND AND MARITIME COLUMBUS, OHIO 43218-3990	SIZE A		5962-88669
		REVISION LEVEL F	SHEET 22

4.3.2 Groups C and D inspections.

- a. End-point electrical parameters shall be as specified in table II herein.
- b. Steady-state life test conditions, method 1005 of MIL-STD-883.
 - (1) Test condition C or D. The test circuit shall be maintained by the manufacturer under document revision level control and shall be made available to the preparing or acquiring activity upon request. The test circuit shall specify the inputs, outputs, biases, and power dissipation, as applicable, in accordance with the intent specified in method 1005 of MIL-STD-883.
 - (2) $T_A = +125^{\circ}\text{C}$, minimum.
 - (3) Test duration: 1,000 hours, except as permitted by method 1005 of MIL-STD-883.

5. PACKAGING

5.1 Packaging requirements. The requirements for packaging shall be in accordance with MIL-PRF-38535, appendix A.

6. NOTES

6.1 Intended use. Microcircuits conforming to this drawing are intended for use for Government microcircuit applications (original equipment), design applications, and logistics purposes.

6.2 Replaceability. Microcircuits covered by this drawing will replace the same generic device covered by a contractor-prepared specification or drawing.

6.3 Configuration control of SMD's. All proposed changes to existing SMD's will be coordinated with the users of record for the individual documents. This coordination will be accomplished using DD Form 1692, Engineering Change Proposal.

6.4 Record of users. Military and industrial users shall inform DLA Land and Maritime when a system application requires configuration control and the applicable SMD to that system. DLA Land and Maritime will maintain a record of users and this list will be used for coordination and distribution of changes to the drawings. Users of drawings covering microelectronics devices (FSC 5962) should contact DLA Land and Maritime-VA, telephone (614) 692-8108.

6.5 Comments. Comments on this drawing should be directed to DLA Land and Maritime-VA, Columbus, Ohio 43218-3990, or telephone (614) 692-0540.

6.6 Approved sources of supply. Approved sources of supply are listed in MIL-HDBK-103 and QML-38535. The vendors listed in MIL-HDBK-103 and QML-38535 have agreed to this drawing and a certificate of compliance (see 3.6 herein) has been submitted to and accepted by DLA Land and Maritime-VA.

STANDARD MICROCIRCUIT DRAWING DLA LAND AND MARITIME COLUMBUS, OHIO 43218-3990	SIZE A		5962-88669
		REVISION LEVEL F	SHEET 23

STANDARD MICROCIRCUIT DRAWING BULLETIN

DATE: 16-02-01

Approved sources of supply for SMD 5962-88669 are listed below for immediate acquisition information only and shall be added to MIL-HDBK-103 and QML-38535 during the next revision. MIL-HDBK-103 and QML-38535 will be revised to include the addition or deletion of sources. The vendors listed below have agreed to this drawing and a certificate of compliance has been submitted to and accepted by DLA Land and Maritime-VA. This information bulletin is superseded by the next dated revision of MIL-HDBK-103 and QML-38535. DLA Land and Maritime maintains an online database of all current sources of supply at <http://www.landandmaritime.dla.mil/Programs/Smcr/>.

Standard microcircuit drawing PIN <u>1/</u>	Vendor CAGE number	Vendor similar PIN <u>2/</u>
5962-8866901UA	0C7V7 <u>3/</u>	CY7C429-80KMB IDT7203S80EB
5962-8866901XA	0C7V7 <u>3/</u> <u>3/</u>	CY7C428-80DMB IDT7203S80DB MM11-67203L-50/883
5962-8866901YA	0C7V7	CY7C429-80DMB
5962-8866901ZA	0C7V7 <u>3/</u> <u>3/</u>	CY7C429-80LMB IDT7203S80LB MM4J-67203L-50/883
5962-8866902UA	0C7V7 <u>3/</u>	CY7C429-65KMB IDT7203S65EB
5962-8866902XA	0C7V7 <u>3/</u> <u>3/</u>	CY7C428-65DMB IDT7203S65DB MM11-67203L-50/883
5962-8866902YA	0C7V7	CY7C429-65DMB
5962-8866902ZA	0C7V7 <u>3/</u> <u>3/</u>	CY7C429-65LMB IDT7203S65LB MM4J-67203L-50/883
5962-8866903UA	0C7V7 <u>3/</u> <u>3/</u>	CY7C429-50KMB IDT7203S50EB MT52C9020F-50883C
5962-8866903XA	0C7V7 <u>3/</u> <u>3/</u> <u>3/</u> <u>3/</u>	CY7C428-50DMB IDT7203S50DB MM11-67203L-50/883 AM7203A-50/BXA MT52C9020CW-50883C
5962-8866903YA	0C7V7 <u>3/</u>	CY7C429-50DMB MT52C9020C-50883C
5962-8866903ZA	0C7V7 <u>3/</u> <u>3/</u> <u>3/</u> <u>3/</u>	CY7C429-50LMB IDT7203S50LB MM4J-67203L-50/883 AM7203A-50/BUA MT52C9020EC-50883C
5962-8866904UA	0C7V7 <u>3/</u> <u>3/</u>	CY7C429-40KMB IDT7203S40EB MT52C9020F-40883C

See footnotes at end of table.

STANDARD MICROCIRCUIT DRAWING BULLETIN – Continued.

DATE: 16-02-01

Standard microcircuit drawing PIN 1/	Vendor CAGE number	Vendor similar PIN 2/
5962-8866904XA	0C7V7 <u>3/</u> <u>3/</u> <u>3/</u>	CY7C428-40DMB IDT7203S40DB MM11-67203L-40/883 MT52C9020CW-40883C
5962-8866904YA	0C7V7 <u>3/</u>	CY7C429-40DMB MT52C9020C-40883C
5962-8866904ZA	0C7V7 <u>3/</u> <u>3/</u> <u>3/</u>	CY7C429-40LMB IDT7203S40LB MM4J-67203L-40/883 MT52C9020EC-40883C
5962-8866905UA	0C7V7 <u>3/</u> <u>3/</u>	CY7C429-30KMB IDT7203S30XEB MT52C9020F-30883C
5962-8866905XA	0C7V7 <u>3/</u> <u>3/</u> <u>3/</u> <u>3/</u>	CY7C428-30DMB IDT7203S30DB MM11-67203L-30/883 MT52C9020CW-30883C AM7203A-30/BXA
5962-8866905YA	0C7V7 0SP21 <u>3/</u>	CY7C429-30DMB IDT7203S30TDB MT52C9020C-30883C
5962-8866905ZA	0C7V7 0SP21 <u>3/</u> <u>3/</u> <u>3/</u>	CY7C429-30LMB IDT7203S30LB MM4J-67203L-30/883 MT52C9020EC-30883C AM7203A-30/BUA
5962-8866906UA	0C7V7 <u>3/</u> <u>3/</u> <u>3/</u>	CY7C429-20KMB IDT7203S20XEB MT52C9020F-20883C AM7203A-20/BYA
5962-8866906XA	0C7V7 <u>3/</u> <u>3/</u> <u>3/</u>	CY7C428-20DMB IDT7203S20DB MT52C9020CW-20883C AM7203A-20/BXA
5962-8866906YA	0C7V7 0SP21 <u>3/</u>	CY7C429-20DMB IDT7203S20TDB MT52C9020C-20883C
5962-8866906ZA	0C7V7 0SP21 <u>3/</u> <u>3/</u>	CY7C429-20LMB IDT7203S20LB MT52C9020EC-20883C AM7203A-20/BUA

See footnotes at end of table.

STANDARD MICROCIRCUIT DRAWING BULLETIN – Continued.

DATE: 16-02-01

Standard microcircuit drawing PIN <u>1/</u>	Vendor CAGE number	Vendor similar PIN <u>2/</u>
5962-8866907UA	0C7V7	CY7C429-25KMB
5962-8866907XA	0C7V7	CY7C428-25DMB
5962-8866907YA	0C7V7	CY7C429-25DMB
5962-8866907ZA	0C7V7	CY7C429-25LMB

1/ The lead finish shown for each PIN representing a hermetic package is the most readily available from the manufacturer listed for that part. If the desired lead finish is not listed contact the vendor to determine its availability.

2/ Caution. Do not use this number for item acquisition. Items acquired to this number may not satisfy the performance requirements of this drawing.

3/ Not available from an approved source of supply.

Vendor CAGE number

Vendor name and address

0C7V7

e2v, Inc.
dba QP Semiconductor, Inc.
765 Sycamore Drive
Milpitas, CA 95035

0SP21

Integrated Device Technology, Inc.
6 Jenner STE 100
Irvine, CA 92618-3855

The information contained herein is disseminated for convenience only and the Government assumes no liability whatsoever for any inaccuracies in the information bulletin.