HM51W16165A Series HM51W18165A Series

1048576-word × 16-bit Dynamic Random Access Memory

HITACHI

ADE-203-372B (Z)

Rev. 2.0

Jul. 2, 1996

Description

The Hitachi HM51W16165A Series, HM51W18165A Series are CMOS dynamic RAMs organized as 1,048,576-word × 16-bit. They employ the most advanced CMOS technology for high performance and low power. HM51W16165A Series, HM51W18165A Series offer Extended Data Out (EDO) Page Mode as a high speed access mode.

Features

- Single 3.3 V (± 0.3 V)
- High speed
 - Access time: 60 ns/70 ns/80 ns (max)
- Low power dissipation
 - Active mode : 468 mW/414 mW/360 mW (max) (HM51W16165A Series)
: 666 mW/594 mW/540 mW (max) (HM51W18165A Series)
 - Standby mode : 7.2 mW (max)
: 0.54 mW (max) (L-version)
- EDO page mode capability
- Long refresh period
 - 4096 refresh cycles : 64 ms (HM51W16165A Series)
: 128 ms (L-version)
 - 1024 refresh cycles : 16 ms (HM51W18165A Series)
: 128 ms (L-version)

This specification is fully compatible with the 16-Mbit DRAM specifications from TEXAS INSTRUMENTS.



HM51W16165A Series, HM51W18165A Series

- 4 variations of refresh
 - RAS-only refresh
 - CAS-before-RAS refresh
 - Hidden refresh
 - Self refresh (L-version)
- 2CAS-byte control
- Battery backup operation (L-version)

Ordering Information

Type No.	Access time	Package
HM51W16165AJ-6	60 ns	400-mil 42-pin plastic SOJ (CP-42D)
HM51W16165AJ-7	70 ns	
HM51W16165AJ-8	80 ns	
HM51W16165ALJ-6	60 ns	
HM51W16165ALJ-7	70 ns	
HM51W16165ALJ-8	80 ns	
HM51W18165AJ-6	60 ns	
HM51W18165AJ-7	70 ns	
HM51W18165AJ-8	80 ns	
HM51W18165ALJ-6	60 ns	
HM51W18165ALJ-7	70 ns	
HM51W18165ALJ-8	80 ns	
HM51W16165ATT-6	60 ns	400-mil 50-pin plastic TSOP II (TTP-50/44DC)
HM51W16165ATT-7	70 ns	
HM51W16165ATT-8	80 ns	
HM51W16165ALTT-6	60 ns	
HM51W16165ALTT-7	70 ns	
HM51W16165ALTT-8	80 ns	
HM51W18165ATT-6	60 ns	
HM51W18165ATT-7	70 ns	
HM51W18165ATT-8	80 ns	
HM51W18165ALTT-6	60 ns	
HM51W18165ALTT-7	70 ns	
HM51W18165ALTT-8	80 ns	

HM51W16165A Series, HM51W18165A Series

Pin Arrangement

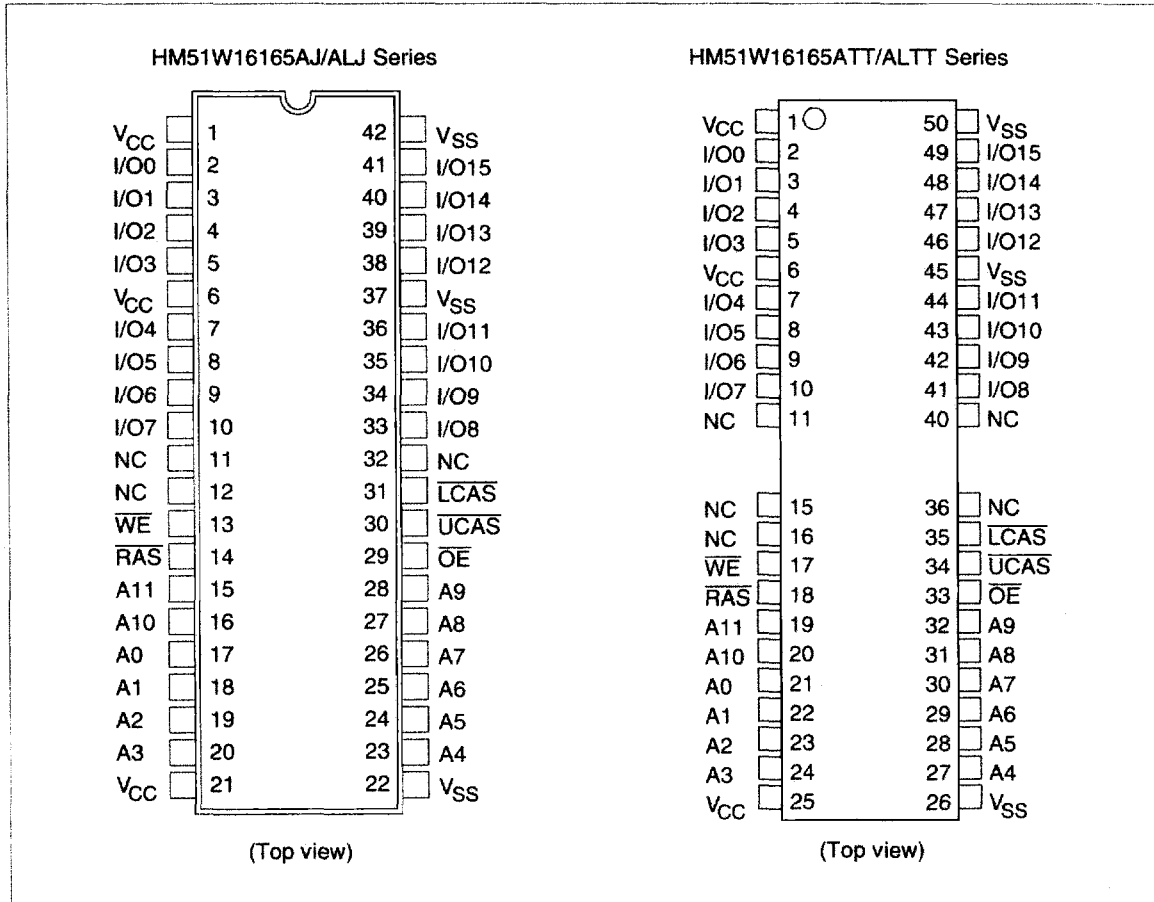

Pin Description

Pin name	Function
A0 to A11	Address input — Row/Refresh address A0 to A11 — Column address A0 to A7
I/O0 to I/O15	Data input/Data output
RAS	Row address strobe
UCAS, LCAS	Column address strobe
WE	Read/Write enable
OE	Output enable
V _{cc}	Power supply
V _{ss}	Ground
NC	No connection

HM51W16165A Series, HM51W18165A Series

Pin Arrangement

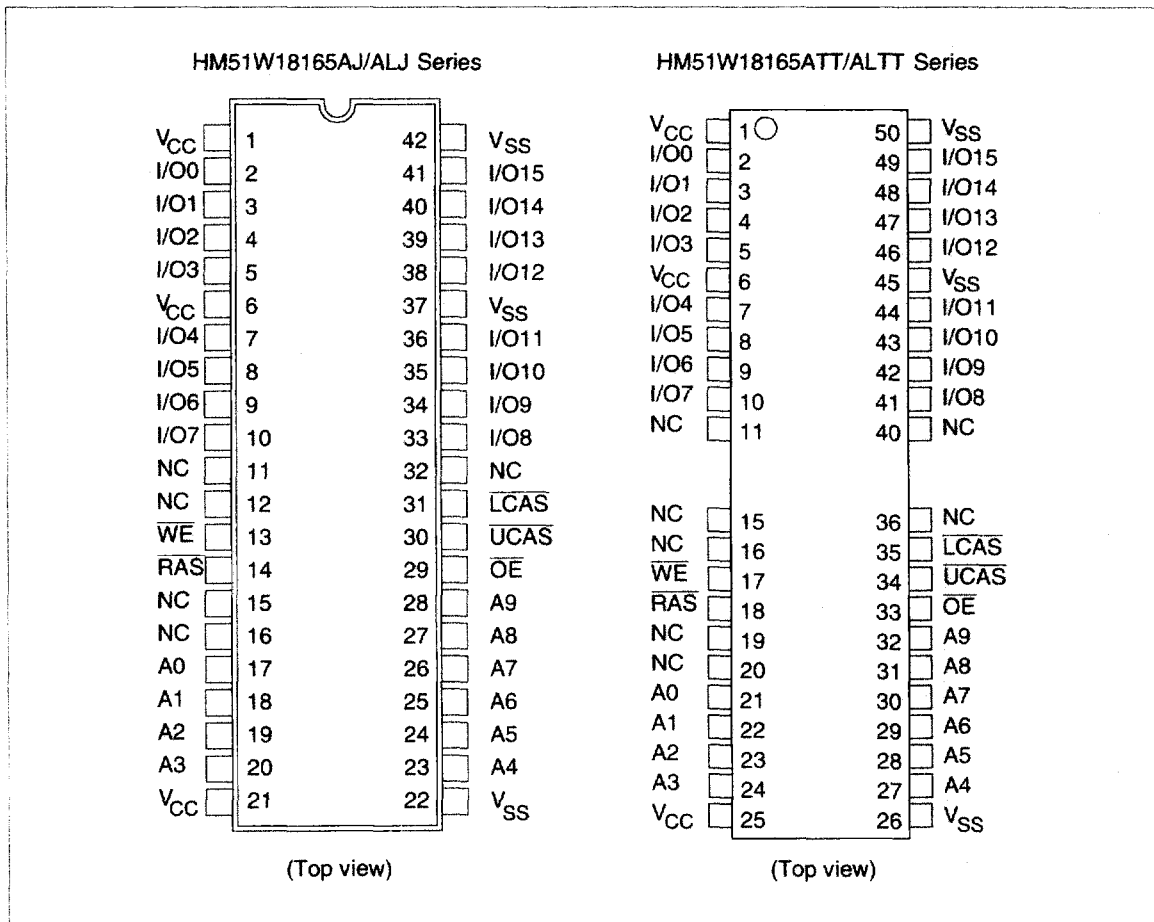

Pin Description

Pin name	Function
A0 to A9	Address input — Row/Refresh address A0 to A9 — Column address A0 to A9
I/O0 to I/O15	Data input/Data output
RAS	Row address strobe
UCAS, LCAS	Column address strobe
WE	Read/Write enable
OE	Output enable
V _{CC}	Power supply
V _{SS}	Ground
NC	No connection

HM51W16165A Series, HM51W18165A Series

Block Diagram

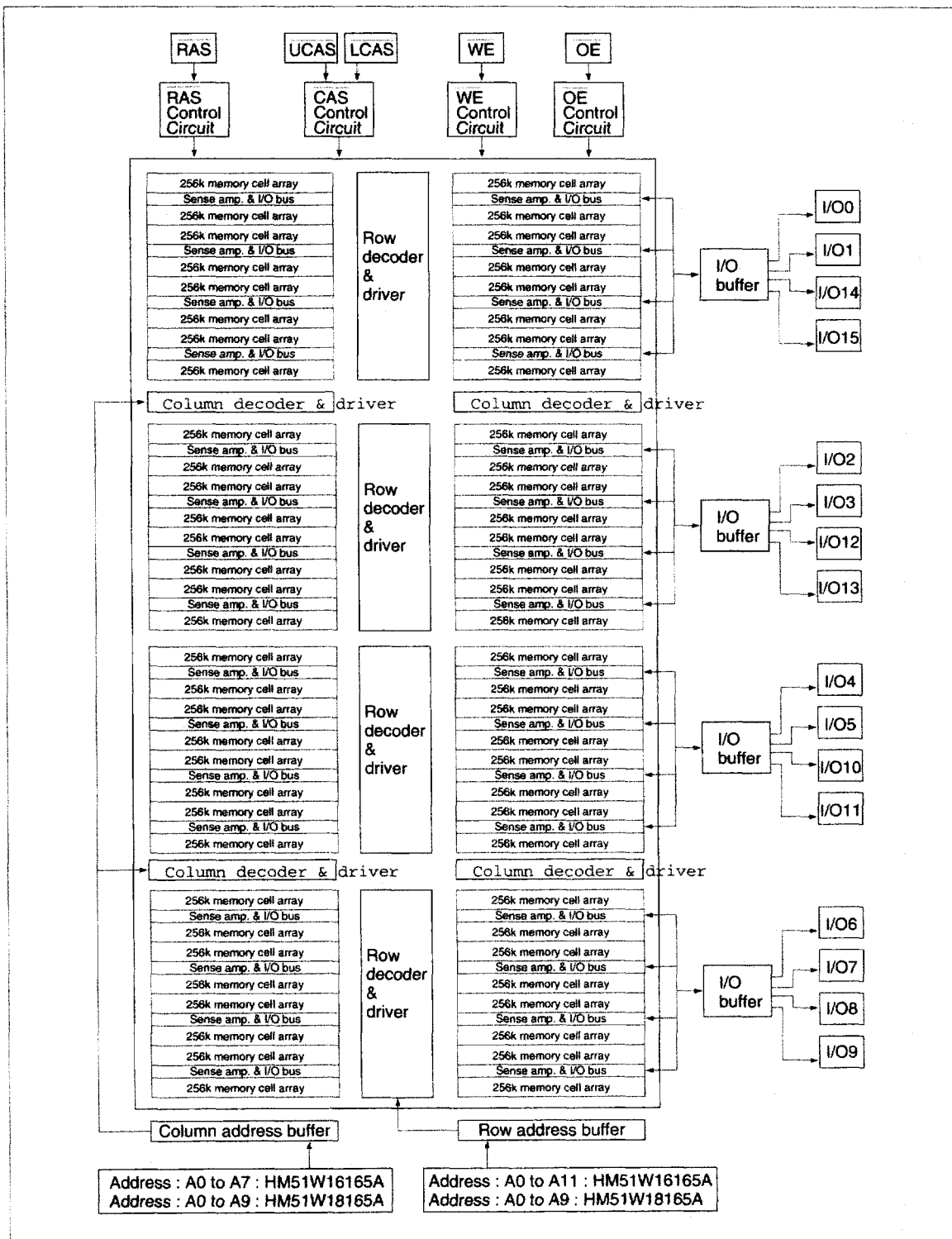

HM51W16165A Series, HM51W18165A Series

Truth Table

RAS	LCAS	UCAS	WE	OE	Output		Operation
H	D	D	D	D	Open		Standby
L	L	H	H	L	Valid	Lower byte	Read cycle
L	H	L	H	L	Valid	Upper byte	
L	L	L	H	L	Valid	Word	
L	L	H	L* ²	D	Open	Lower byte	Early write cycle
L	H	L	L* ²	D	Open	Upper byte	
L	L	L	L* ²	D	Open	Word	
L	L	H	L* ²	H	Undefined	Lower byte	Delayed write cycle
L	H	L	L* ²	H	Undefined	Upper byte	
L	L	L	L* ²	H	Undefined	Word	
L	L	H	H to L	L to H	Valid	Lower byte	Read-modify-write cycle
L	H	L	H to L	L to H	Valid	Upper byte	
L	L	L	H to L	L to H	Valid	Word	
L	H	H	D	D	Open	Word	$\overline{\text{RAS}}$ -only refresh cycle
H to L	H	L	D	D	Open	Word	$\overline{\text{CAS}}$ -before- $\overline{\text{RAS}}$ refresh cycle or
H to L	L	H	D	D	Open	Word	Self refresh cycle (L-version)
H to L	L	L	D	D	Open	Word	
L	L	L	H	H	Open		Read cycle (Output disabled)

Notes: 1. H: High (inactive) L: Low (active) D: H or L

2. $t_{\text{wcs}} \geq 0$ ns Early write cycle

$t_{\text{wcs}} < 0$ ns Delayed write cycle

3. Mode is determined by the OR function of the $\overline{\text{UCAS}}$ and $\overline{\text{LCAS}}$. (Mode is set by the earliest of $\overline{\text{UCAS}}$ and $\overline{\text{LCAS}}$ active edge and reset by the latest of $\overline{\text{UCAS}}$ and $\overline{\text{LCAS}}$ inactive edge.) However write OPERATION and output HIZ control are done independently by each $\overline{\text{UCAS}}$, $\overline{\text{LCAS}}$.

ex. if $\overline{\text{RAS}} = \text{H to L}$, $\overline{\text{UCAS}} = \text{H}$, $\overline{\text{LCAS}} = \text{L}$, then $\overline{\text{CAS}}$ -before- $\overline{\text{RAS}}$ refresh cycle is selected.

HM51W16165A Series, HM51W18165A Series

Absolute Maximum Ratings

Parameter	Symbol	Value	Unit
Voltage on any pin relative to V_{SS}	V_T	-0.5 to $V_{CC} + 0.5$ (≤ 4.6 V (max))	V
Supply voltage relative to V_{SS}	V_{CC}	-0.5 to 4.6	V
Short circuit output current	I_{out}	50	mA
Power dissipation	P_T	1.0	W
Operating temperature	T_{opr}	0 to +70	°C
Storage temperature	T_{stg}	-55 to +125	°C

Recommended DC Operating Conditions ($T_a = 0$ to +70°C)

Parameter	Symbol	Min	Typ	Max	Unit	Notes
Supply voltage	V_{CC}	3.0	3.3	3.6	V	1, 2
Input high voltage	V_{IH}	2.0	—	$V_{CC} + 0.3$	V	1
Input low voltage	V_{IL}	-0.3	—	0.8	V	1

Notes: 1. All voltage referred to V_{SS} .

2. The supply voltage with all V_{CC} pins must be on the same level. The supply voltage with all V_{SS} pins must be on the same level.

HM51W16165A Series, HM51W18165A Series

DC Characteristics

($T_a = 0$ to $+70^\circ\text{C}$, $V_{CC} = 3.3 \text{ V} \pm 0.3 \text{ V}$, $V_{SS} = 0 \text{ V}$) (HM51W16165A Series)

Parameter	Symbol	HM51W16165A						Unit	Test conditions
		-6		-7		-8			
		Min	Max	Min	Max	Min	Max		
Operating current* ¹ , * ²	I_{CC1}	—	100	—	90	—	80	mA	$t_{RC} = \text{min}$
Standby current	I_{CC2}	—	2	—	2	—	2	mA	TTL interface $\overline{\text{RAS}}, \overline{\text{UCAS}}, \overline{\text{LCAS}} = V_{IH}$ Dout = High-Z
		—	1	—	1	—	1	mA	CMOS interface $\overline{\text{RAS}}, \overline{\text{UCAS}},$ $\overline{\text{LCAS}} \geq V_{CC} - 0.2 \text{ V}$ Dout = High-Z
Standby current (L-version)	I_{CC2}	—	150	—	150	—	150	μA	CMOS interface $\overline{\text{RAS}}, \overline{\text{UCAS}},$ $\overline{\text{LCAS}} \geq V_{CC} - 0.2 \text{ V}$ Dout = High-Z
$\overline{\text{RAS}}$ -only refresh current* ²	I_{CC3}	—	100	—	90	—	80	mA	$t_{RC} = \text{min}$
Standby current* ¹	I_{CC5}	—	5	—	5	—	5	mA	$\overline{\text{RAS}} = V_{IH}$ $\overline{\text{UCAS}}, \overline{\text{LCAS}} = V_{IL}$ Dout = enable
$\overline{\text{CAS}}$ -before- $\overline{\text{RAS}}$ refresh current	I_{CC6}	—	100	—	90	—	80	mA	$t_{RC} = \text{min}$
EDO page mode current* ¹ , * ³	I_{CC7}	—	130	—	115	—	100	mA	$t_{HPC} = \text{min}$
Battery backup current* ⁴ (Standby with CBR refresh) (L-version)	I_{CC10}	—	400	—	400	—	400	μA	CMOS interface Dout = High-Z CBR refresh: $t_{RC} = 31.3 \mu\text{s}$ $t_{RAS} \leq 0.3 \mu\text{s}$
Self refresh mode current (L-version)	I_{CC11}	—	250	—	250	—	250	μA	CMOS interface $\overline{\text{RAS}}, \overline{\text{UCAS}},$ $\overline{\text{LCAS}} \leq 0.2 \text{ V}$ Dout = High-Z
Input leakage current	I_{LI}	-10	10	-10	10	-10	10	μA	$0 \text{ V} \leq V_{in} \leq 4.6 \text{ V}$
Output leakage current	I_{LO}	-10	10	-10	10	-10	10	μA	$0 \text{ V} \leq V_{out} \leq 4.6 \text{ V}$ Dout = disable
Output high voltage	V_{OH}	2.4	V_{CC}	2.4	V_{CC}	2.4	V_{CC}	V	High Iout = -2 mA
Output low voltage	V_{OL}	0	0.4	0	0.4	0	0.4	V	Low Iout = 2 mA

Notes: 1. I_{CC} depends on output load condition when the device is selected. I_{CC} max is specified at the output open condition.

2. Address can be changed once or less while $\overline{\text{RAS}} = V_{IL}$.

3. Address can be changed once or less while $\overline{\text{UCAS}}$ and $\overline{\text{LCAS}} = V_{IH}$.

4. $V_{IH} \geq V_{CC} - 0.2 \text{ V}$, $0 \text{ V} \leq V_{IL} \leq 0.2 \text{ V}$.

HM51W16165A Series, HM51W18165A Series

DC Characteristics

($T_a = 0$ to $+70^\circ\text{C}$, $V_{CC} = 3.3\text{ V} \pm 0.3\text{ V}$, $V_{SS} = 0\text{ V}$) (HM51W18165A Series)

Parameter	Symbol	HM51W18165A						Unit	Test conditions
		-6		-7		-8			
		Min	Max	Min	Max	Min	Max		
Operating current* ^{1, *2}	I_{CC1}	—	170	—	150	—	130	mA	$t_{RC} = \text{min}$
Standby current	I_{CC2}	—	2	—	2	—	2	mA	TTL interface $\overline{\text{RAS}}, \overline{\text{UCAS}}, \overline{\text{LCAS}} = V_{IH}$ Dout = High-Z
		—	1	—	1	—	1	mA	CMOS interface $\overline{\text{RAS}}, \overline{\text{UCAS}},$ $\overline{\text{LCAS}} \geq V_{CC} - 0.2\text{ V}$ Dout = High-Z
Standby current (L-version)	I_{CC2}	—	150	—	150	—	150	μA	CMOS interface $\overline{\text{RAS}}, \overline{\text{UCAS}},$ $\overline{\text{LCAS}} \geq V_{CC} - 0.2\text{ V}$ Dout = High-Z
$\overline{\text{RAS}}$ -only refresh current* ²	I_{CC3}	—	170	—	150	—	130	mA	$t_{RC} = \text{min}$
Standby current* ¹	I_{CC5}	—	5	—	5	—	5	mA	$\overline{\text{RAS}} = V_{IH}$ $\overline{\text{UCAS}}, \overline{\text{LCAS}} = V_{IL}$ Dout = enable
$\overline{\text{CAS}}$ -before- $\overline{\text{RAS}}$ refresh current	I_{CC6}	—	170	—	150	—	130	mA	$t_{RC} = \text{min}$
EDO page mode current* ^{1, *3}	I_{CC7}	—	185	—	165	—	150	mA	$t_{HPC} = \text{min}$
Battery backup current* ⁴ (Standby with CBR refresh) (L-version)	I_{CC10}	—	400	—	400	—	400	μA	CMOS interface Dout = High-Z CBR refresh: $t_{RC} = 125\ \mu\text{s}$ $t_{RAS} \leq 0.3\ \mu\text{s}$
Self refresh mode current (L-version)	I_{CC11}	—	250	—	250	—	250	μA	CMOS interface $\overline{\text{RAS}}, \overline{\text{UCAS}},$ $\overline{\text{LCAS}} \leq 0.2\text{ V}$ Dout = High-Z
Input leakage current	I_{LI}	-10	10	-10	10	-10	10	μA	$0\text{ V} \leq V_{in} \leq 4.6\text{ V}$
Output leakage current	I_{LO}	-10	10	-10	10	-10	10	μA	$0\text{ V} \leq V_{out} \leq 4.6\text{ V}$ Dout = disable
Output high voltage	V_{OH}	2.4	V_{CC}	2.4	V_{CC}	2.4	V_{CC}	V	High Iout = -2 mA
Output low voltage	V_{OL}	0	0.4	0	0.4	0	0.4	V	Low Iout = 2 mA

Notes: 1. I_{CC} depends on output load condition when the device is selected. I_{CC} max is specified at the output open condition.

2. Address can be changed once or less while $\overline{\text{RAS}} = V_{IL}$.

3. Address can be changed once or less while $\overline{\text{UCAS}}$ and $\overline{\text{LCAS}} = V_{IH}$.

4. $V_{IH} \geq V_{CC} - 0.2\text{ V}$, $0\text{ V} \leq V_{IL} \leq 0.2\text{ V}$.

HM51W16165A Series, HM51W18165A Series

Capacitance ($T_a = 25^\circ\text{C}$, $V_{CC} = 3.3\text{ V} \pm 0.3\text{ V}$)

Parameter	Symbol	Typ	Max	Unit	Notes
Input capacitance (Address)	C_{I1}	—	5	pF	1
Input capacitance (Clocks)	C_{I2}	—	7	pF	1
Output capacitance (Data-in, Data-out)	$C_{I/O}$	—	7	pF	1, 2

Notes : 1. Capacitance measured with Boonton Meter or effective capacitance measuring method.

2. $\overline{\text{RAS}}$, $\overline{\text{UCAS}}$ and $\overline{\text{LCAS}} = V_{IH}$ to disable Dout.

HM51W16165A Series, HM51W18165A Series

AC Characteristics ($T_a = 0$ to $+70^\circ\text{C}$, $V_{CC} = 3.3\text{ V} \pm 0.3\text{ V}$, $V_{SS} = 0\text{ V}$)*1. *2. *18. *19. *20

Test Conditions

- Input rise and fall time: 2 ns
- Input levels: 0 V, 3.0 V
- Input timing reference levels: 0.8 V, 2.0 V
- Output timing reference levels: 0.8 V, 2.0 V
- Output load: 1 TTL gate + C_L (100 pF) (Including scope and jig)

Read, Write, Read-Modify-Write and Refresh Cycles (Common parameters)

		HM51W16165A/HM51W18165A							
		-6		-7		-8			
Parameter	Symbol	Min	Max	Min	Max	Min	Max	Unit	Notes
Random read or write cycle time	t_{RC}	104	—	124	—	144	—	ns	
$\overline{\text{RAS}}$ precharge time	t_{RP}	40	—	50	—	60	—	ns	
$\overline{\text{CAS}}$ precharge time	t_{CP}	10	—	13	—	15	—	ns	
$\overline{\text{RAS}}$ pulse width	t_{RAS}	60	10000	70	10000	80	10000	ns	
$\overline{\text{CAS}}$ pulse width	t_{CAS}	10	10000	13	10000	15	10000	ns	
Row address setup time	t_{ASR}	0	—	0	—	0	—	ns	
Row address hold time	t_{RAH}	10	—	10	—	10	—	ns	
Column address setup time	t_{ASC}	0	—	0	—	0	—	ns	21
Column address hold time	t_{CAH}	10	—	13	—	15	—	ns	21
$\overline{\text{RAS}}$ to $\overline{\text{CAS}}$ delay time	t_{RCD}	20	45	20	52	20	60	ns	3
$\overline{\text{RAS}}$ to column address delay time	t_{RAD}	15	30	15	35	15	40	ns	4
$\overline{\text{RAS}}$ hold time	t_{RSH}	15	—	18	—	20	—	ns	
$\overline{\text{CAS}}$ hold time	t_{CSH}	48	—	58	—	68	—	ns	23
$\overline{\text{CAS}}$ to $\overline{\text{RAS}}$ precharge time	t_{CRP}	5	—	5	—	5	—	ns	22
$\overline{\text{OE}}$ to Din delay time	t_{OED}	15	—	18	—	20	—	ns	5
$\overline{\text{OE}}$ delay time from Din	t_{DZO}	0	—	0	—	0	—	ns	6
$\overline{\text{CAS}}$ delay time from Din	t_{DZC}	0	—	0	—	0	—	ns	6
Transition time (rise and fall)	t_T	2	50	2	50	2	50	ns	7

HM51W16165A Series, HM51W18165A Series

Read Cycle

Parameter	Symbol	HM51W16165A/HM51W18165A						Unit	Notes
		-6		-7		-8			
		Min	Max	Min	Max	Min	Max		
Access time from $\overline{\text{RAS}}$	t_{RAC}	—	60	—	70	—	80	ns	8, 9
Access time from $\overline{\text{CAS}}$	t_{CAC}	—	15	—	18	—	20	ns	9, 10, 17
Access time from address	t_{AA}	—	30	—	35	—	40	ns	9, 11, 17
Access time from $\overline{\text{OE}}$	t_{OEA}	—	15	—	18	—	20	ns	9
Read command setup time	t_{RCS}	0	—	0	—	0	—	ns	21
Read command hold time to $\overline{\text{CAS}}$	t_{RCH}	0	—	0	—	0	—	ns	12, 22
Read command hold time from $\overline{\text{RAS}}$	t_{RCHR}	60	—	70	—	80	—	ns	
Read command hold time to $\overline{\text{RAS}}$	t_{RRH}	5	—	5	—	5	—	ns	12
Column address to $\overline{\text{RAS}}$ lead time	t_{RAL}	30	—	35	—	40	—	ns	
Column address to $\overline{\text{CAS}}$ lead time	t_{CAL}	18	—	23	—	28	—	ns	
$\overline{\text{CAS}}$ to output in low-Z	t_{CLZ}	0	—	0	—	0	—	ns	
Output data hold time	t_{OH}	3	—	3	—	3	—	ns	27
Output data hold time from $\overline{\text{OE}}$	t_{OHO}	3	—	3	—	3	—	ns	
Output buffer turn-off time	t_{OFF}	—	15	—	15	—	15	ns	13, 27
Output buffer turn-off to $\overline{\text{OE}}$	t_{OEZ}	—	15	—	15	—	15	ns	13
$\overline{\text{CAS}}$ to Din delay time	t_{CDD}	15	—	18	—	20	—	ns	5
Output data hold time from $\overline{\text{RAS}}$	t_{OHR}	3	—	3	—	3	—	ns	27
Output buffer turn-off to $\overline{\text{RAS}}$	t_{OFR}	—	15	—	15	—	15	ns	27
Output buffer turn-off to $\overline{\text{WE}}$	t_{WEZ}	—	15	—	15	—	15	ns	
$\overline{\text{WE}}$ to Din delay time	t_{WED}	15	—	18	—	20	—	ns	
$\overline{\text{RAS}}$ to Din delay time	t_{RDD}	15	—	18	—	20	—	ns	

HM51W16165A Series, HM51W18165A Series

Write Cycle

		HM51W16165A/HM51W18165A							
		-6		-7		-8			
Parameter	Symbol	Min	Max	Min	Max	Min	Max	Unit	Notes
Write command setup time	t_{WCS}	0	—	0	—	0	—	ns	14, 21
Write command hold time	t_{WCH}	10	—	13	—	15	—	ns	21
Write command pulse width	t_{WP}	10	—	10	—	10	—	ns	
Write command to \overline{RAS} lead time	t_{RWL}	10	—	13	—	15	—	ns	
Write command to \overline{CAS} lead time	t_{CWL}	10	—	13	—	15	—	ns	23
Data-in setup time	t_{DS}	0	—	0	—	0	—	ns	15, 23
Data-in hold time	t_{DH}	10	—	13	—	15	—	ns	15, 23

Read-Modify-Write Cycle

		HM51W16165A/HM51W18165A							
		-6		-7		-8			
Parameter	Symbol	Min	Max	Min	Max	Min	Max	Unit	Notes
Read-modify-write cycle time	t_{RWC}	136	—	161	—	185	—	ns	
\overline{RAS} to \overline{WE} delay time	t_{RWD}	79	—	92	—	104	—	ns	14
\overline{CAS} to \overline{WE} delay time	t_{CWD}	34	—	40	—	44	—	ns	14
Column address to \overline{WE} delay time	t_{AWD}	49	—	57	—	64	—	ns	14
\overline{OE} hold time from \overline{WE}	t_{OEH}	15	—	18	—	20	—	ns	

Refresh Cycle

		HM51W16165A/HM51W18165A							
		-6		-7		-8			
Parameter	Symbol	Min	Max	Min	Max	Min	Max	Unit	Notes
\overline{CAS} setup time (CBR refresh cycle)	t_{CSR}	5	—	5	—	5	—	ns	21
\overline{CAS} hold time (CBR refresh cycle)	t_{CHR}	10	—	10	—	10	—	ns	22
\overline{RAS} precharge to \overline{CAS} hold time	t_{RPC}	0	—	0	—	0	—	ns	21

HM51W16165A Series, HM51W18165A Series

EDO Page Mode Cycle

Parameter	Symbol	HM51W16165A/HM51W18165A						Unit	Notes
		-6		-7		-8			
		Min	Max	Min	Max	Min	Max		
EDO page mode cycle time	t_{HPC}	25	—	30	—	35	—	ns	25
EDO page mode \overline{RAS} pulse width	t_{RASP}	—	100000	—	100000	—	100000	ns	16
Access time from \overline{CAS} precharge	t_{CPA}	—	35	—	40	—	45	ns	9, 17
\overline{RAS} hold time from \overline{CAS} precharge	t_{CPRH}	35	—	40	—	45	—	ns	
Output data hold time from \overline{CAS} low	t_{DOH}	3	—	3	—	3	—	ns	9, 17
\overline{CAS} hold time referred \overline{OE}	t_{COL}	10	—	13	—	15	—	ns	
\overline{CAS} to \overline{OE} setup time	t_{COP}	5	—	5	—	5	—	ns	
Read command hold time from \overline{CAS} precharge	t_{RCHC}	35	—	40	—	45	—	ns	

EDO Page Mode Read-Modify-Write Cycle

Parameter	Symbol	HM51W16165A/HM51W18165A						Unit	Notes
		-6		-7		-8			
		Min	Max	Min	Max	Min	Max		
EDO page mode read-modify-write cycle time	t_{HPRWC}	68	—	79	—	88	—	ns	
\overline{WE} delay time from \overline{CAS} precharge	t_{CPW}	54	—	62	—	69	—	ns	14

Refresh (HM51W16165A Series)

Parameter	Symbol	Max	Unit	Note
Refresh period	t_{REF}	64	ms	4096 cycles
Refresh period (L-version)	t_{REF}	128	ms	4096 cycles

Refresh (HM51W18165A Series)

Parameter	Symbol	Max	Unit	Note
Refresh period	t_{REF}	16	ms	1024 cycles
Refresh period (L-version)	t_{REF}	128	ms	1024 cycles

HM51W16165A Series, HM51W18165A Series

Self Refresh Mode (L-version)

Parameter	Symbol	HM51W16165AL/HM51W18165AL						Unit	Notes
		-6		-7		-8			
		Min	Max	Min	Max	Min	Max		
RAS pulse width (self refresh)	t_{RASS}	100	—	100	—	100	—	μ s	
RAS precharge time (self refresh)	t_{RPS}	110	—	130	—	150	—	ns	
CAS hold time (self refresh)	t_{CHS}	-50	—	-50	—	-50	—	ns	

- Notes:
- AC measurements assume $t_T = 2$ ns.
 - An initial pause of 200 μ s is required after power up followed by a minimum of eight initialization cycles (any combination of cycles containing RAS-only refresh or CAS-before-RAS refresh).
 - Operation with the t_{RCD} (max) limit insures that t_{RAC} (max) can be met, t_{RCD} (max) is specified as a reference point only; if $t_{RCD} \geq t_{RAD}$ (max) + t_{AA} (max) - t_{CAC} (max), then access time is controlled exclusively by t_{CAC} .
 - Operation with the t_{RAD} (max) limit insures that t_{RAC} (max) can be met, t_{RAD} (max) is specified as a reference point only; if t_{RAD} is greater than the specified t_{RAD} (max) limit, then access time is controlled exclusively by t_{AA} .
 - Either t_{OED} or t_{CDD} must be satisfied.
 - Either t_{DZO} or t_{DZC} must be satisfied.
 - V_{IH} (min) and V_{IL} (max) are reference levels for measuring timing of input signals. Also, transition times are measured between V_{IH} (min) and V_{IL} (max).
 - Assumes that $t_{RCD} \leq t_{RCD}$ (max) and $t_{RAD} \leq t_{RAD}$ (max). If t_{RCD} or t_{RAD} is greater than the maximum recommended value shown in this table, t_{RAC} exceeds the value shown.
 - Measured with a load circuit equivalent to 1 TTL loads and 100 pF.
 - Assumes that $t_{RCD} \geq t_{RCD}$ (max) and $t_{RCD} + t_{CAC}$ (max) $\geq t_{RAD} + t_{AA}$ (max).
 - Assumes that $t_{RAD} \geq t_{RAD}$ (max) and $t_{RCD} + t_{CAC}$ (max) $\leq t_{RAD} + t_{AA}$ (max).
 - Either t_{RCH} or t_{RRH} must be satisfied for a read cycles.
 - t_{OFF} (max) and t_{OEZ} (max) define the time at which the outputs achieve the open circuit condition and are not referred to output voltage levels.
 - t_{WCS} , t_{RWD} , t_{CWD} , t_{AWD} and t_{CPW} are not restrictive operating parameters. They are included in the data sheet as electrical characteristics only; if $t_{WCS} \geq t_{WCS}$ (min), the cycle is an early write cycle and the data out pin will remain open circuit (high impedance) throughout the entire cycle; if $t_{RWD} \geq t_{RWD}$ (min), $t_{CWD} \geq t_{CWD}$ (min), and $t_{AWD} \geq t_{AWD}$ (min), or $t_{CWD} \geq t_{CWD}$ (min), $t_{AWD} \geq t_{AWD}$ (min) and $t_{CPW} \geq t_{CPW}$ (min), the cycle is a read-modify-write and the data output will contain data read from the selected cell; if neither of the above sets of conditions is satisfied, the condition of the data out (at access time) is indeterminate.
 - These parameters are referred to UCAS and LCAS leading edge in early write cycles and to WE leading edge in delayed write or read-modify-write cycles.
 - t_{RASP} defines RAS pulse width in EDO page mode cycles.
 - Access time is determined by the longest among t_{AA} , t_{CAC} and t_{CPA} .
 - In delayed write or read-modify-write cycles, OE must disable output buffer prior to applying data to the device. After RAS is reset, if $t_{OEH} \geq t_{CWL}$, the I/O pin will remain open circuit (high impedance); if $t_{OEH} < t_{CWL}$, invalid data will be out at each I/O.
 - When both UCAS and LCAS go low at the same time, all 16-bit data are written into the device. UCAS and LCAS cannot be staggered within the same write/read cycles.
 - All the V_{CC} and V_{SS} pins shall be supplied with the same voltages.

HM51W16165A Series, HM51W18165A Series

21. t_{ASC} , t_{CAH} , t_{RCS} , t_{WCS} , t_{WCH} , t_{CSR} and t_{RPC} are determined by the earlier falling edge of \overline{UCAS} or \overline{LCAS} .
22. t_{CRP} , t_{CHR} , t_{RCH} , t_{CPA} and t_{CPW} are determined by the later rising edge of \overline{UCAS} or \overline{LCAS} .
23. t_{CWL} , t_{DH} , t_{DS} and t_{CHS} should be satisfied by both \overline{UCAS} and \overline{LCAS} .
24. t_{CP} is determined by the time that both \overline{UCAS} and \overline{LCAS} are high.
25. t_{HPC} (min) can be achieved during a series of EDO page mode write cycles or EDO page mode read cycles. If both write and read operation are mixed in a EDO page mode \overline{RAS} cycle (EDO page mode mix cycle (1), (2)), minimum value of \overline{CAS} cycle ($t_{CAS} + t_{CP} + 2 t_T$) becomes greater than the specified t_{HPC} (min) value. The value of \overline{CAS} cycle time of mixed EDO page mode is shown in EDO page mode mix cycle (1) and (2).
26. When output buffers are enabled once, sustain the low impedance state until valid data is obtained. When output buffer is turned on and off within a very short time, generally it causes large V_{CC}/V_{SS} line noise, which causes to degrade V_{IH} min/ V_{IL} max level.
27. Data output turns off and becomes high impedance from later rising edge of \overline{RAS} and \overline{CAS} . Hold time and turn off time are specified by the timing specifications of later rising edge of \overline{RAS} and \overline{CAS} between t_{OHR} and t_{OH} , and between t_{OFR} and t_{OFF} .
28. Please do not use t_{RASS} timing, $10 \mu s \leq t_{RASS} \leq 100 \mu s$. During this period, the device is in transition state from normal operation mode to self refresh mode. If $t_{RASS} \geq 100 \mu s$, then \overline{RAS} precharge time should use t_{RPS} instead of t_{RP} .
29. If you use distributed CBR refresh mode with 15.6 μs interval in normal read/write cycle, CBR refresh should be executed within 15.6 μs immediately after exiting from and before entering into self refresh mode.
30. If you use \overline{RAS} only refresh or CBR burst refresh mode in normal read/write cycle, 4096 or 1024 cycles (4096 cycles: HM51W16165A Series, 1024 cycles: HM51W18165A Series) of distributed CBR refresh with 15.6 μs interval should be executed within 64 or 16 ms (64 ms: HM51W16165A, 16 ms: HM51W18165A) immediately after exiting from and before entering into the self refresh mode.
31. Repetitive self refresh mode without refreshing all memory is not allowed. Once you exit from self refresh mode, all memory cells need to be refreshed before re-entering the self refresh mode again.
32. H or L (H: $V_{IH}(\min) \leq V_{IN} \leq V_{IH}(\max)$, L: $V_{IL}(\min) \leq V_{IN} \leq V_{IL}(\max)$)
 Invalid Dout

HM51W16165A Series, HM51W18165A Series

Notes concerning 2CAS control

Please do not separate the $\overline{UCAS}/\overline{LCAS}$ operation timing intentionally. However skew between $\overline{UCAS}/\overline{LCAS}$ are allowed under the following conditions.

1. Each of the $\overline{UCAS}/\overline{LCAS}$ should satisfy the timing specifications individually.
2. Different operation mode for upper/lower byte is not allowed; such as following.

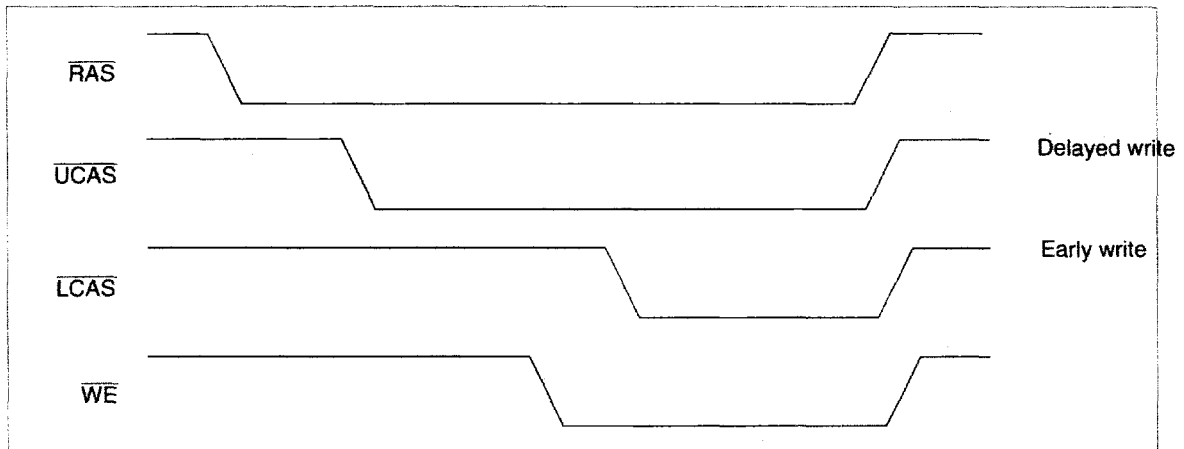

3. Closely separated upper/lower byte control is not allowed. However when the condition ($t_{CP} \leq t_{UL}$) is satisfied, EDO page mode can be performed.

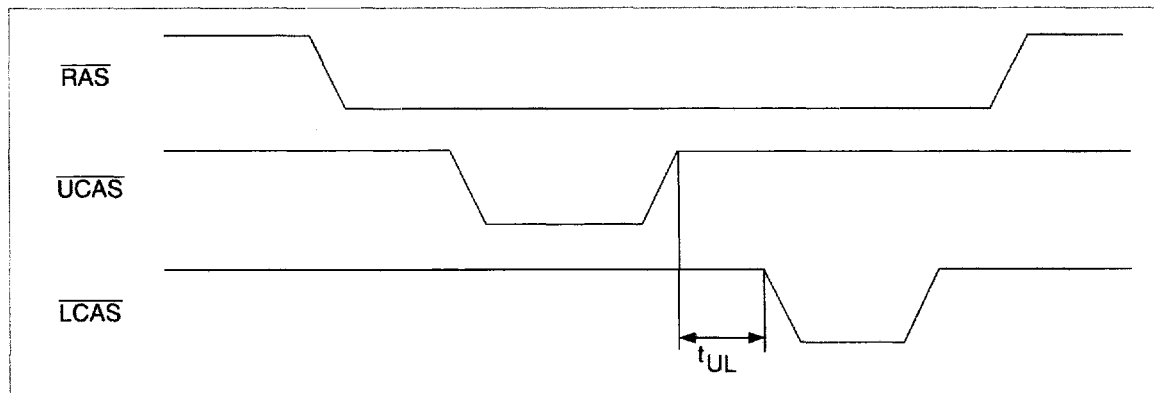

4. Byte control operation by remaining \overline{UCAS} or \overline{LCAS} high is guaranteed.

HM51W16165A Series, HM51W18165A Series

Timing Waveforms*32

Read Cycle

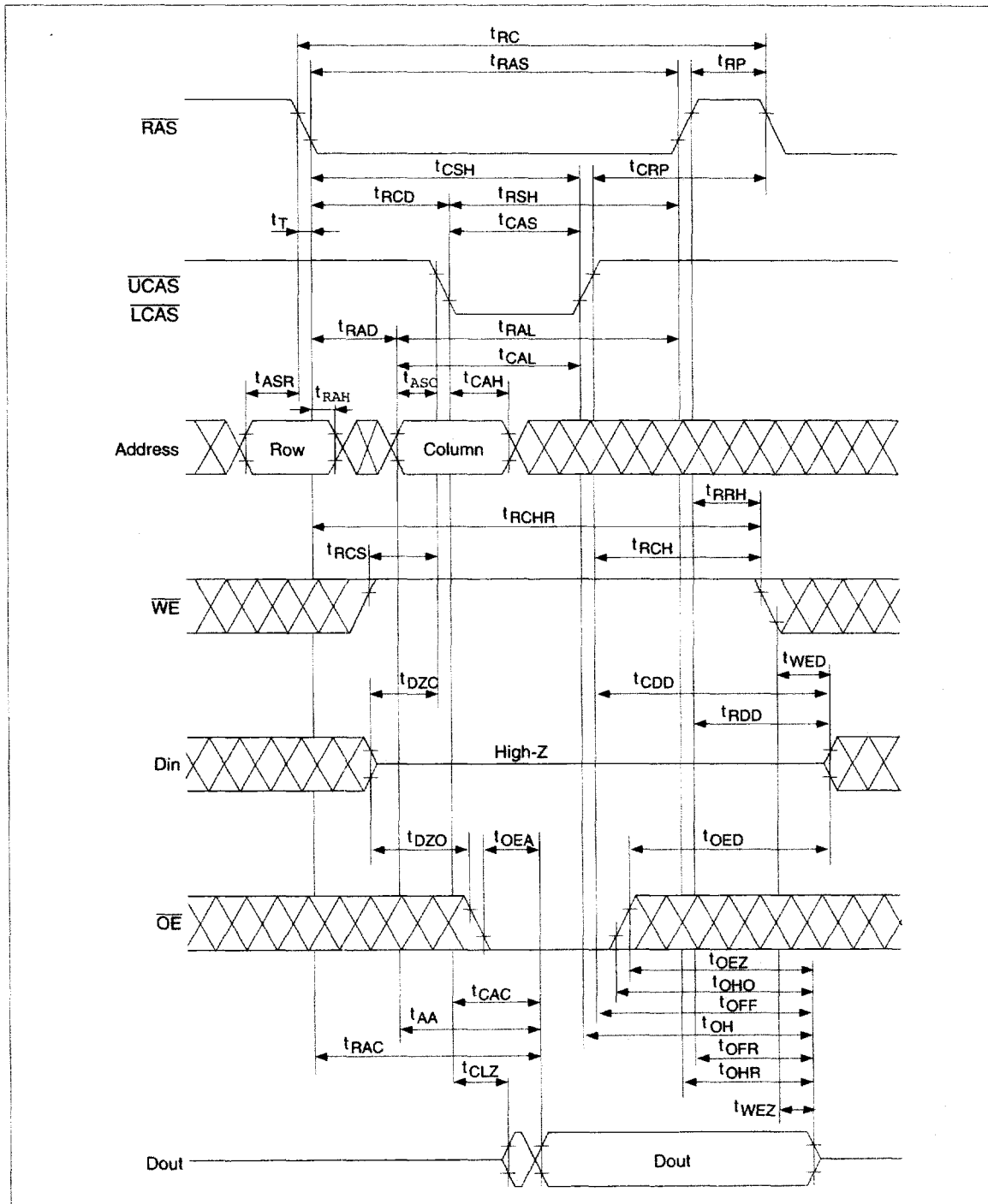

HITACHI

HM51W16165A Series, HM51W18165A Series

Early Write Cycle

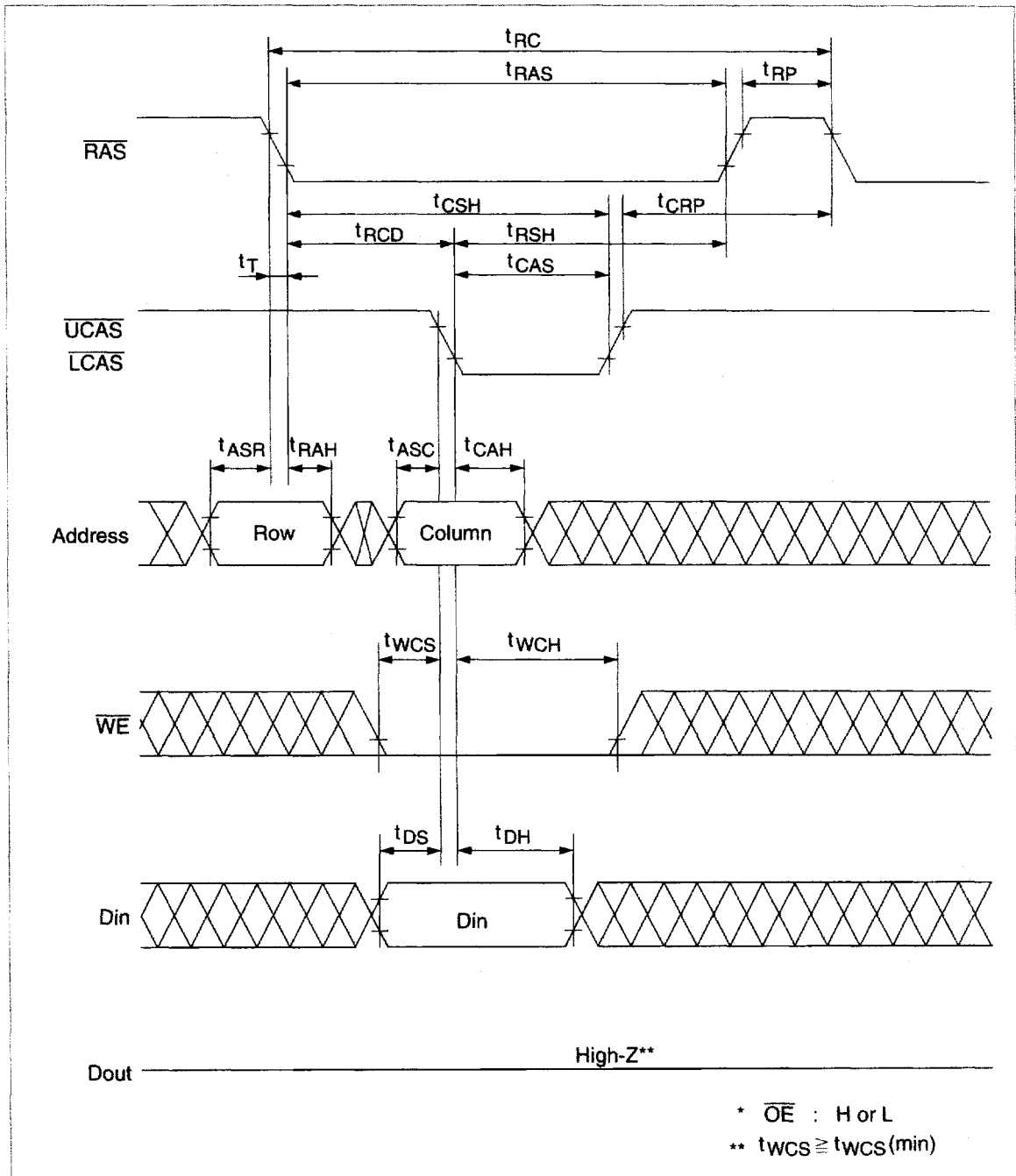

HM51W16165A Series, HM51W18165A Series

Delayed Write Cycle*18

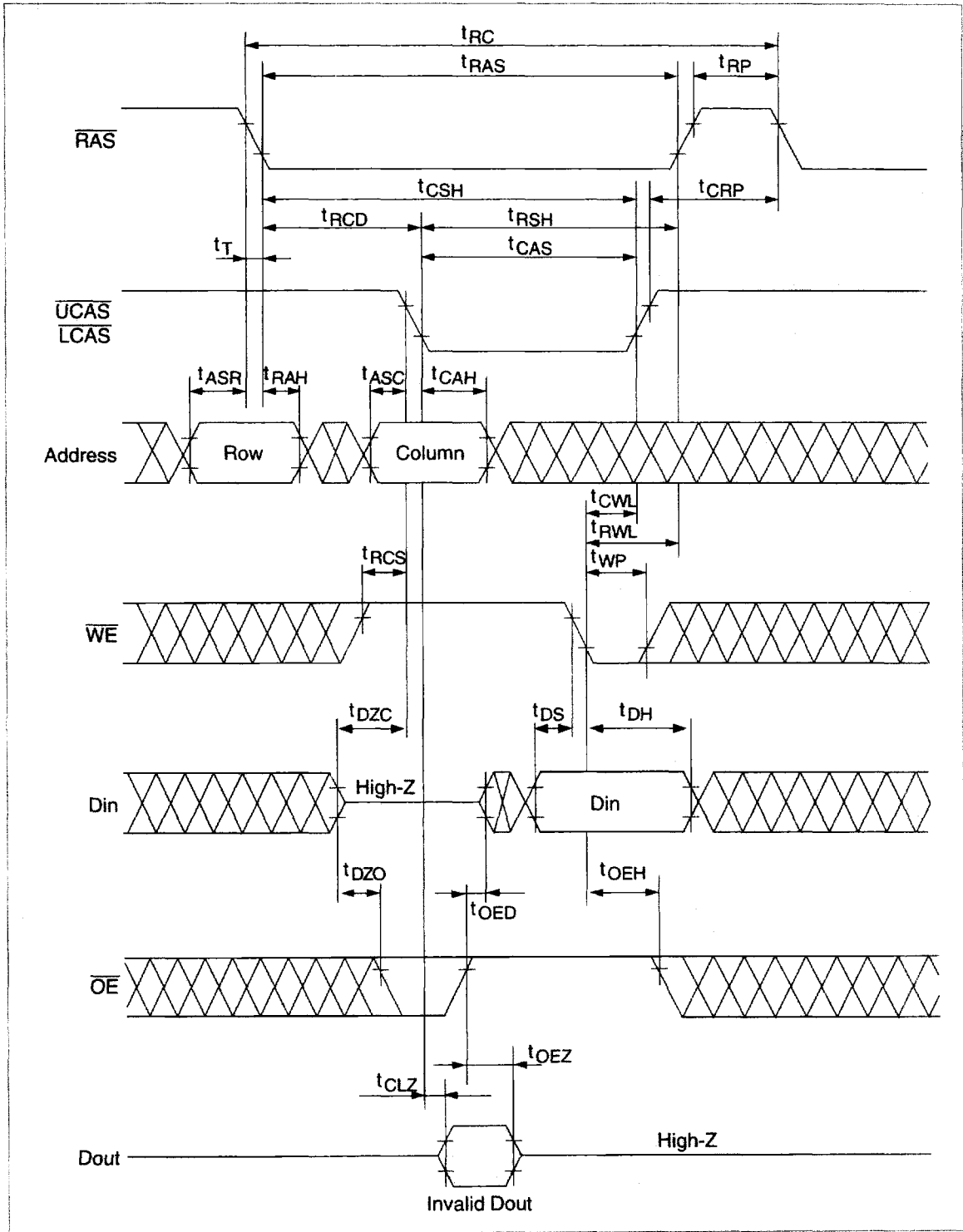

HM51W16165A Series, HM51W18165A Series

Read-Modify-Write Cycle*18

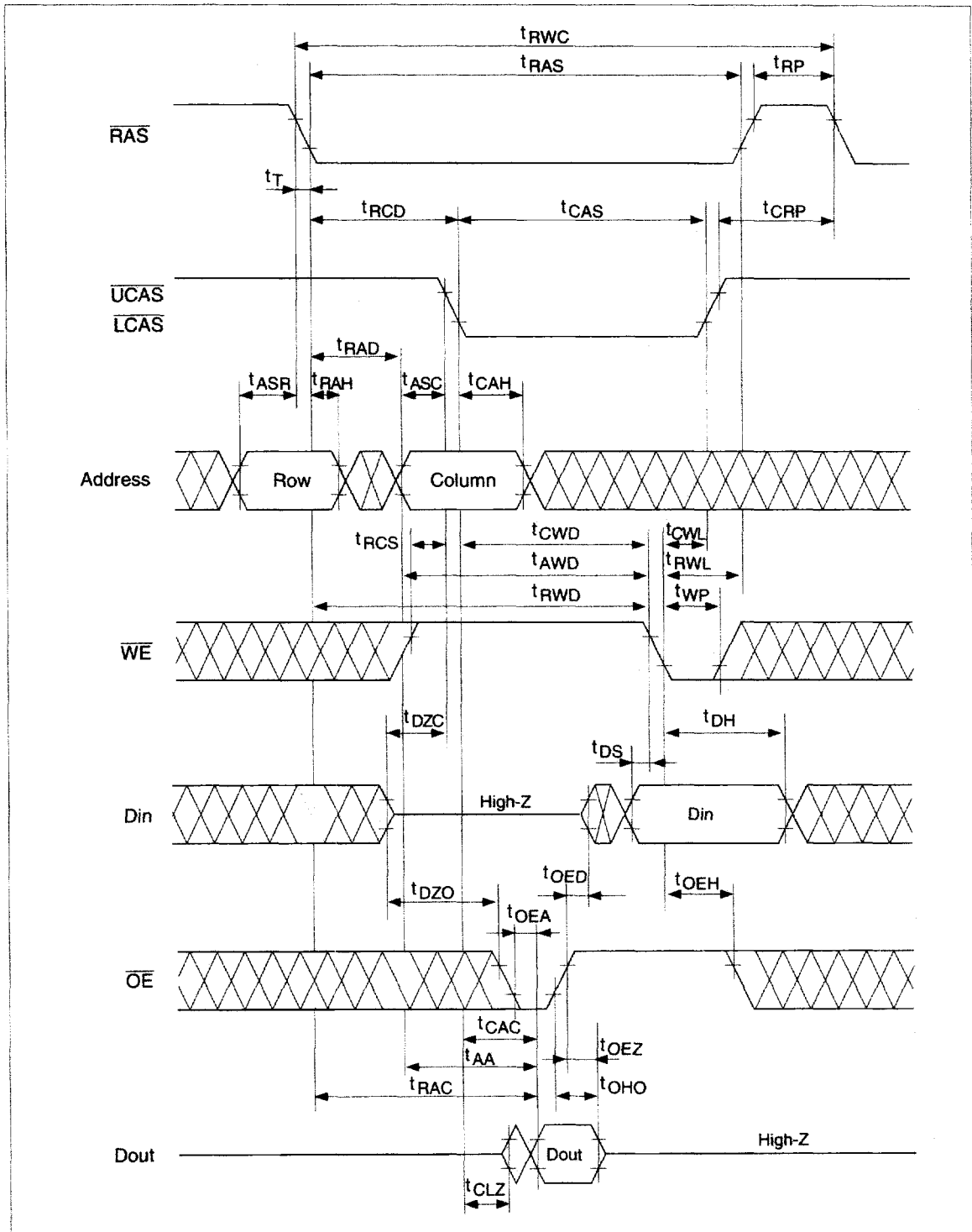

HM51W16165A Series, HM51W18165A Series

$\overline{\text{RAS}}$ -Only Refresh Cycle

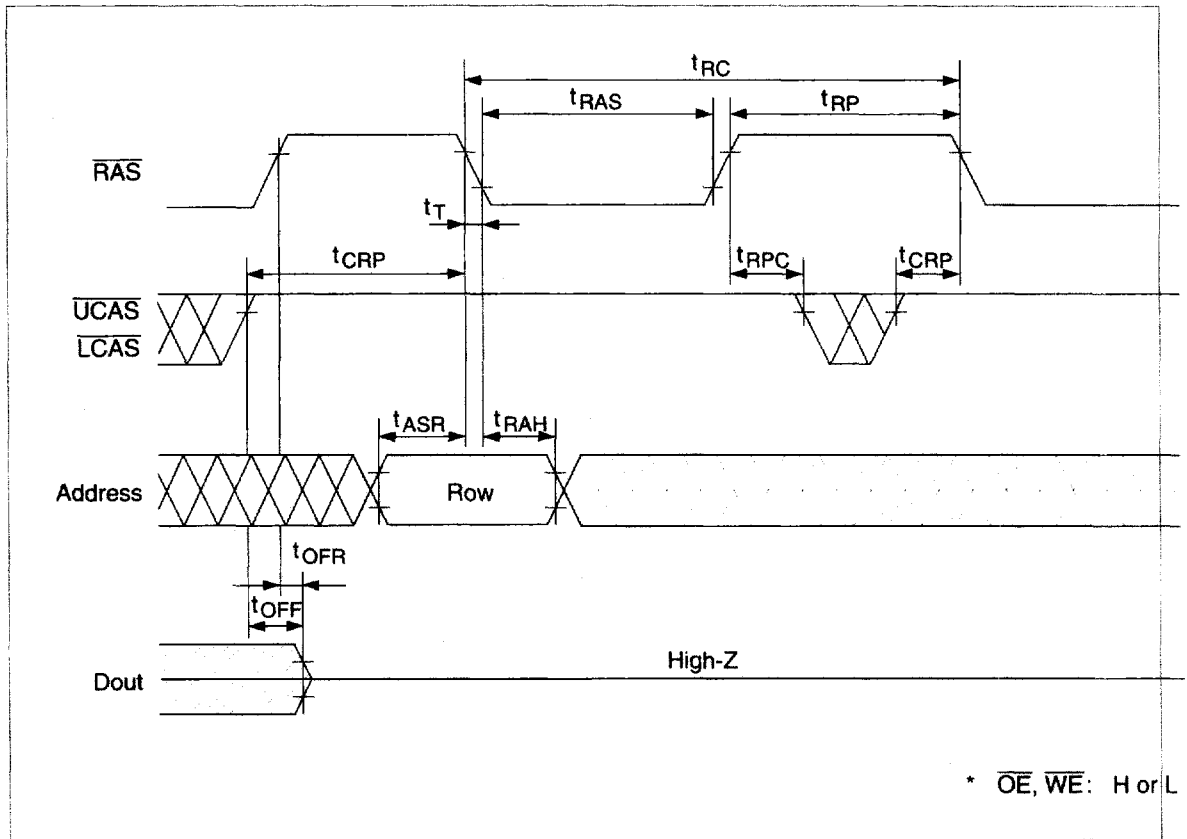

HM51W16165A Series, HM51W18165A Series

CAS-Before-RAS Refresh Cycle

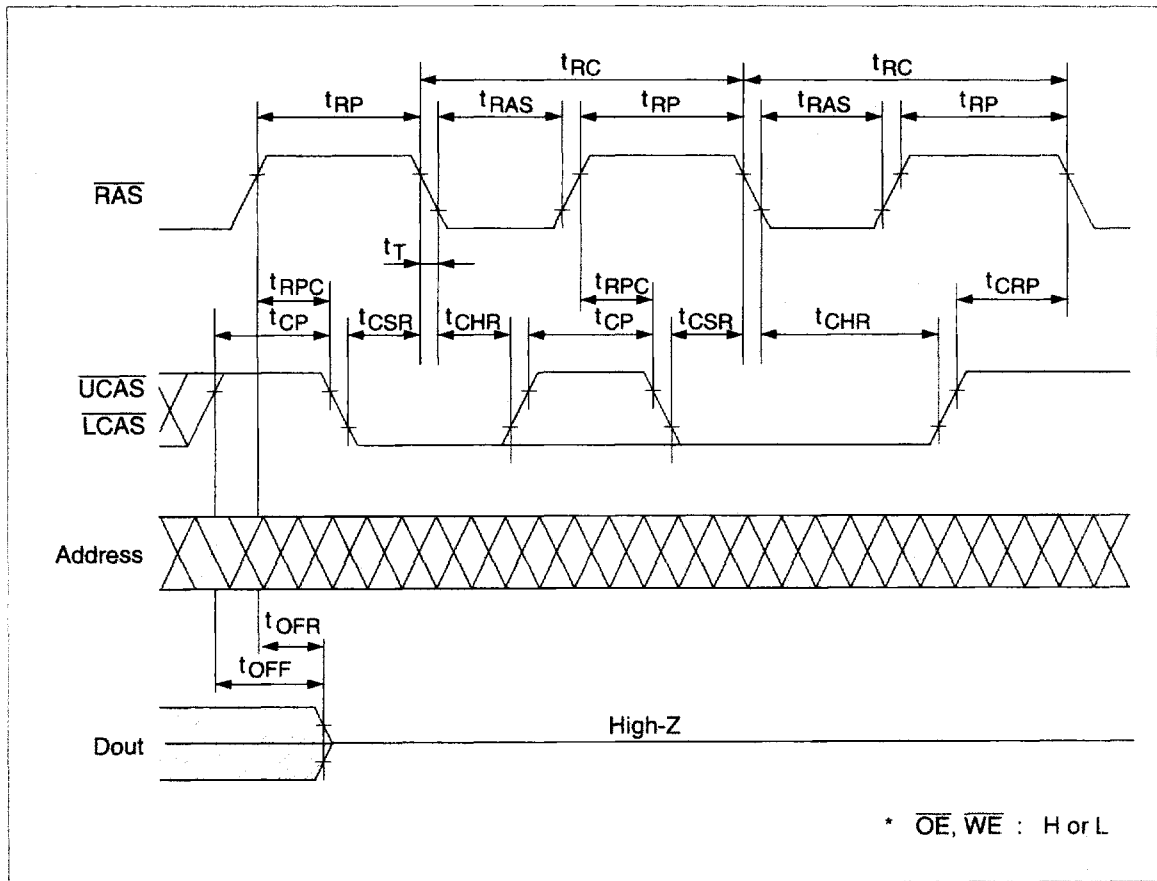

HM51W16165A Series, HM51W18165A Series

Hidden Refresh Cycle

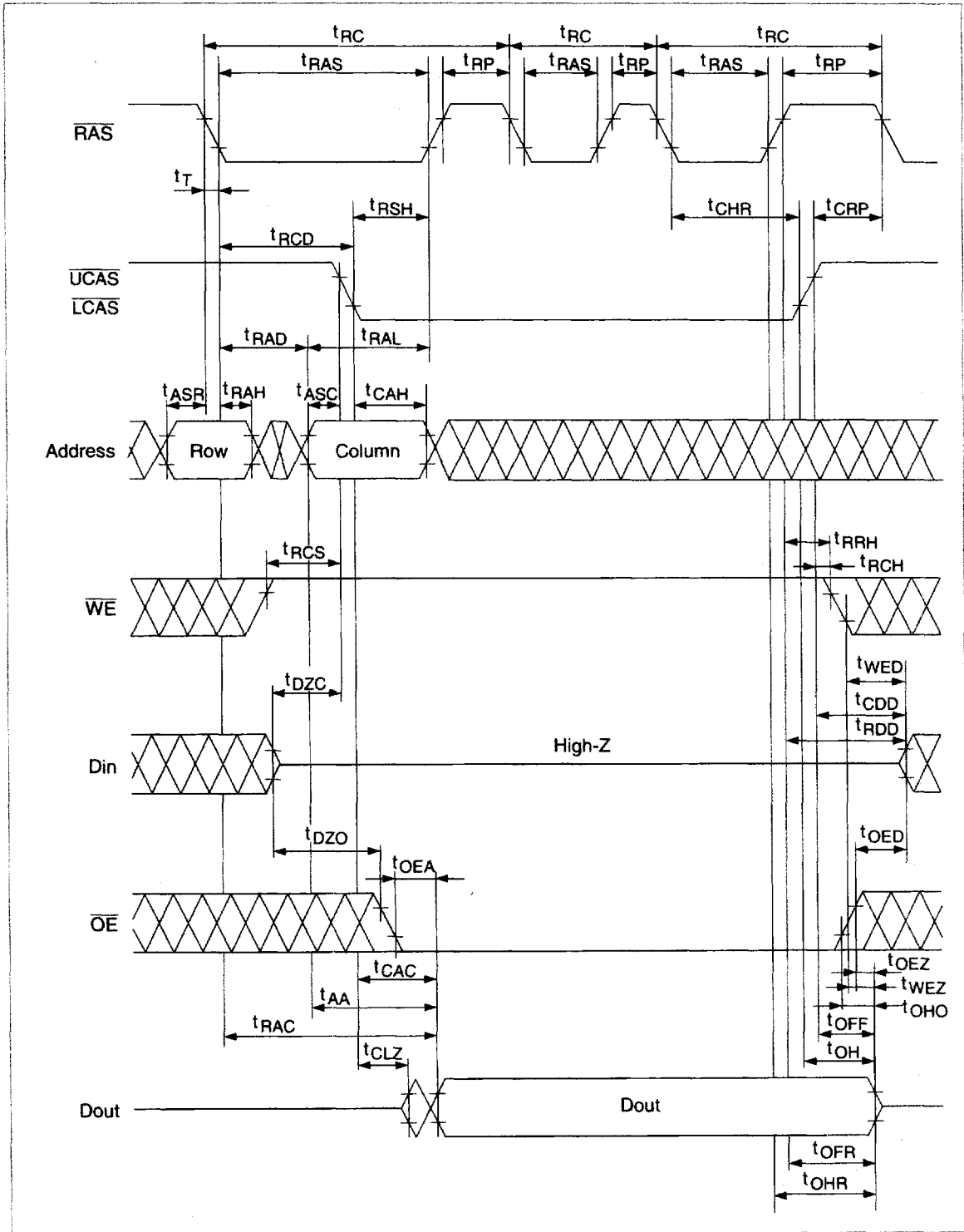

HITACHI

HM51W16165A Series, HM51W18165A Series

EDO Page Mode Read Cycle

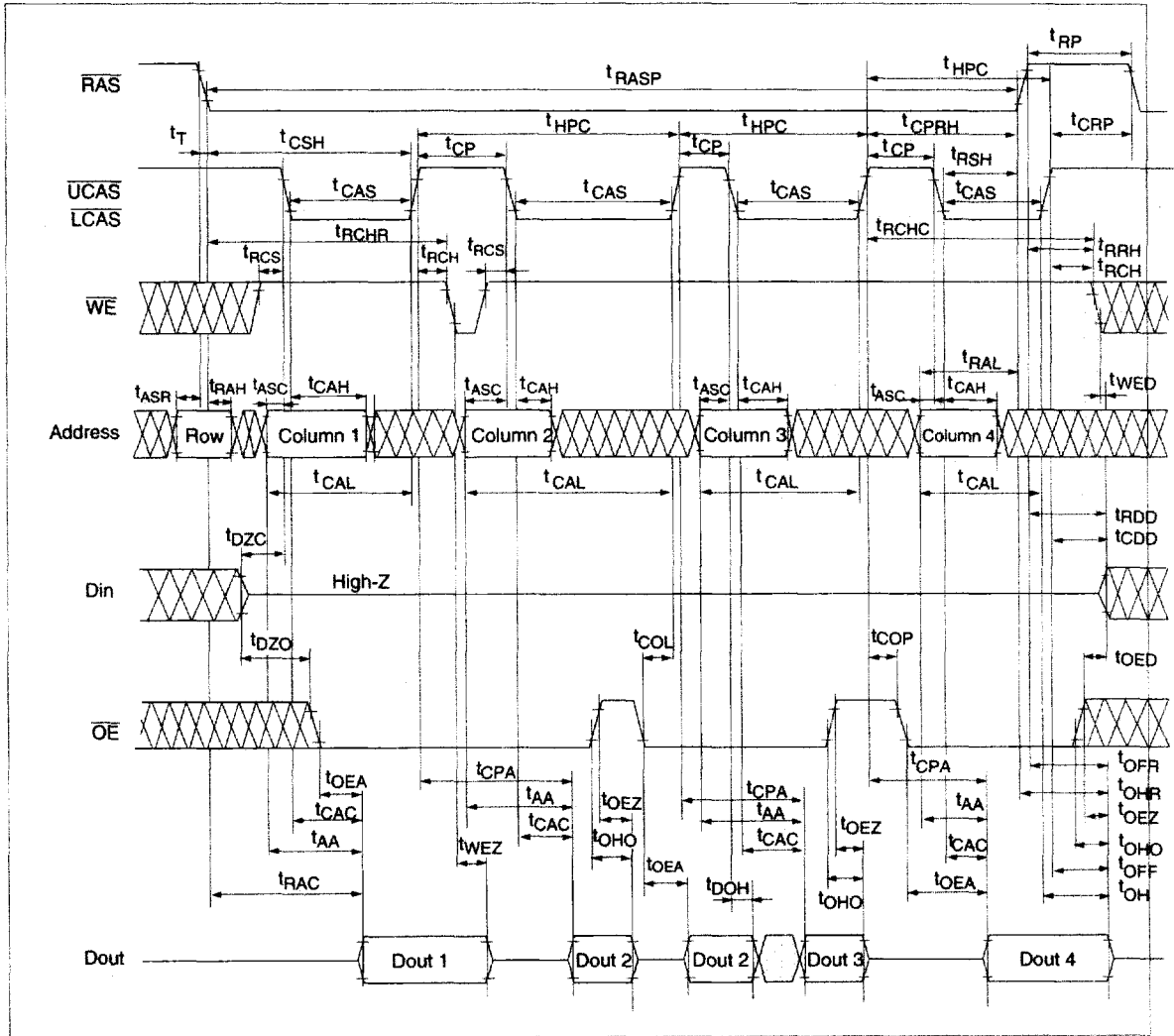

HM51W16165A Series, HM51W18165A Series

EDO Page Mode Read Cycle (2CAS)

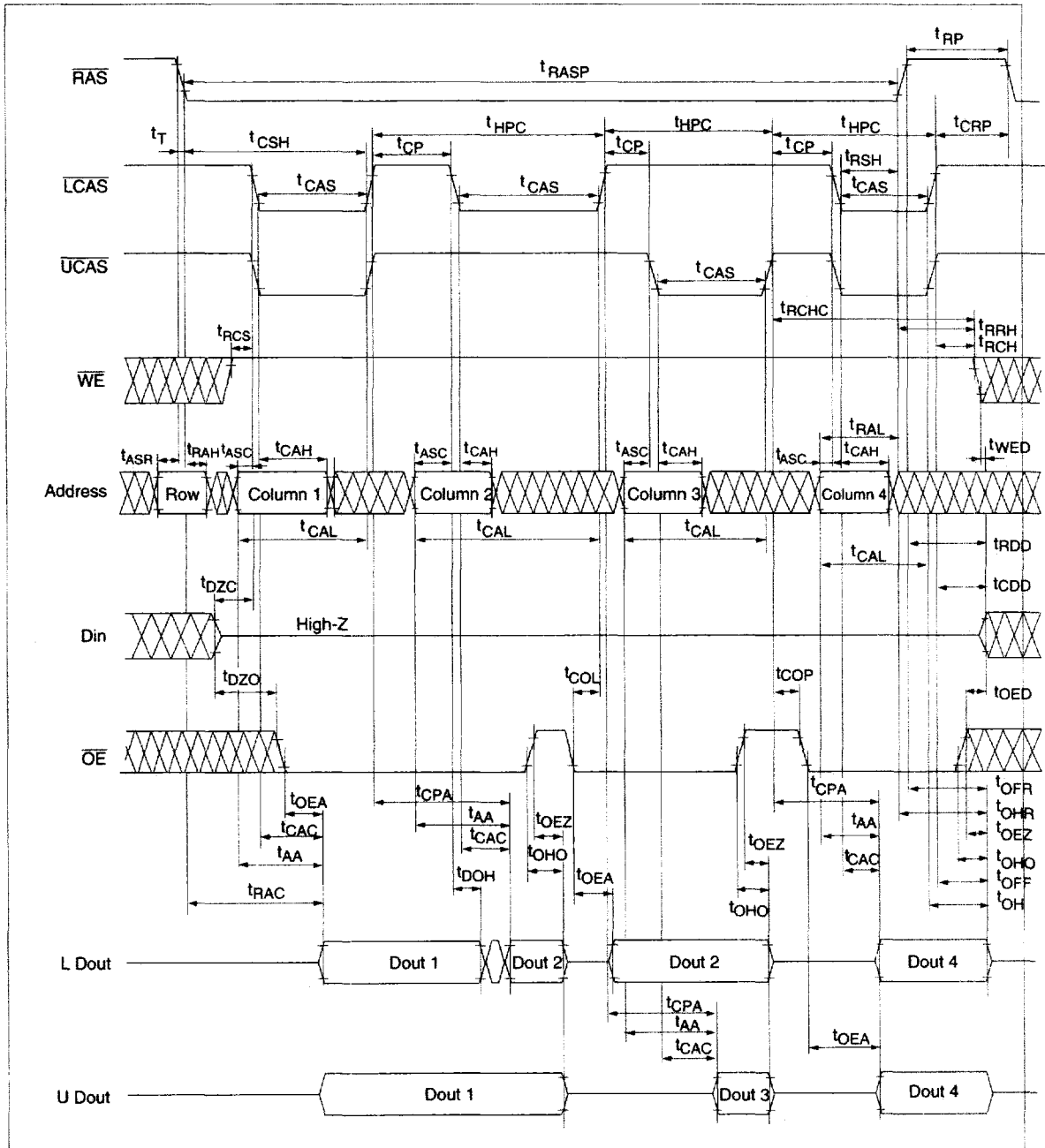

HITACHI

HM51W16165A Series, HM51W18165A Series

EDO Page Mode Early Write Cycle

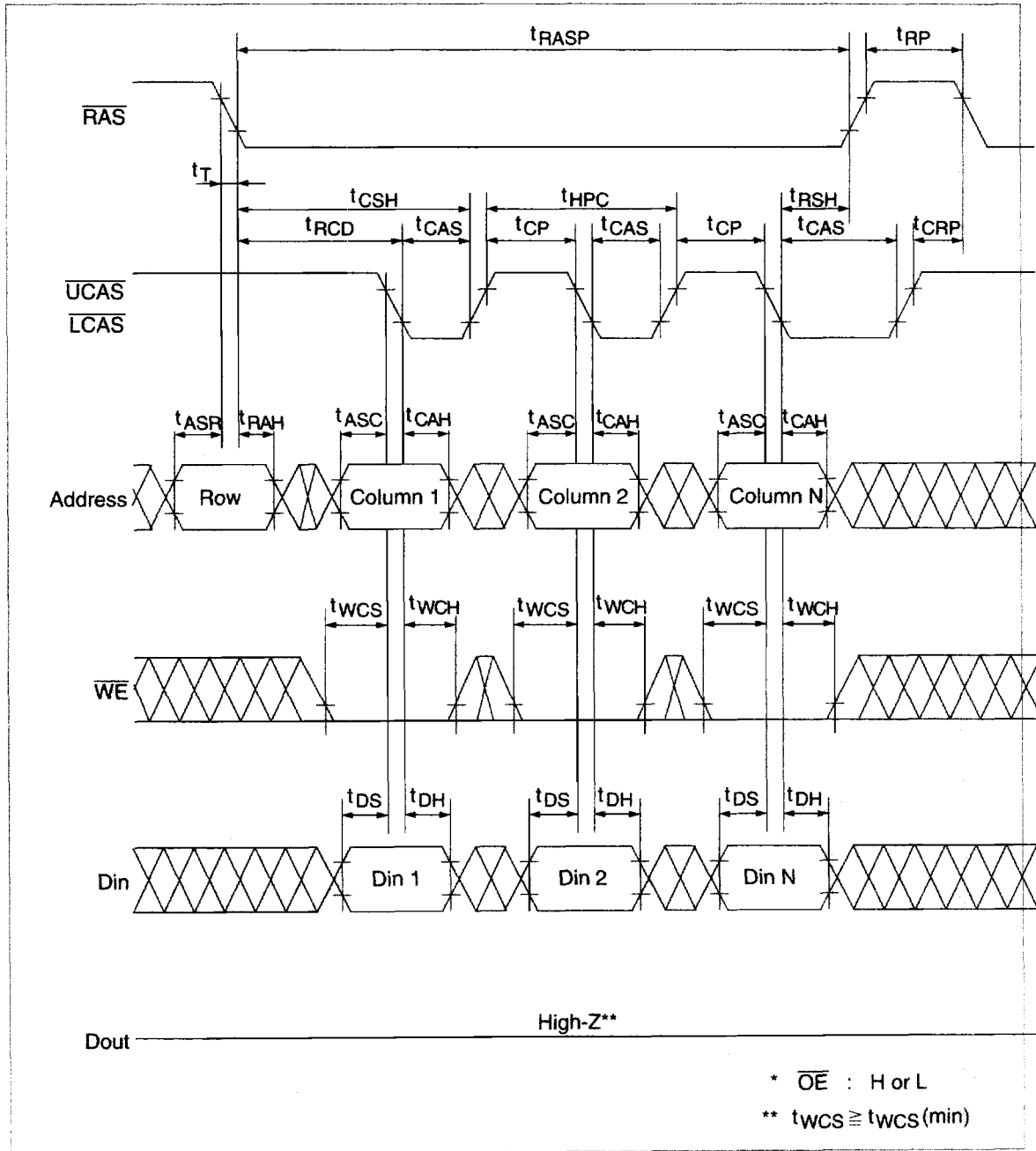

HM51W16165A Series, HM51W18165A Series

EDO Page Mode Delayed Write Cycle*18

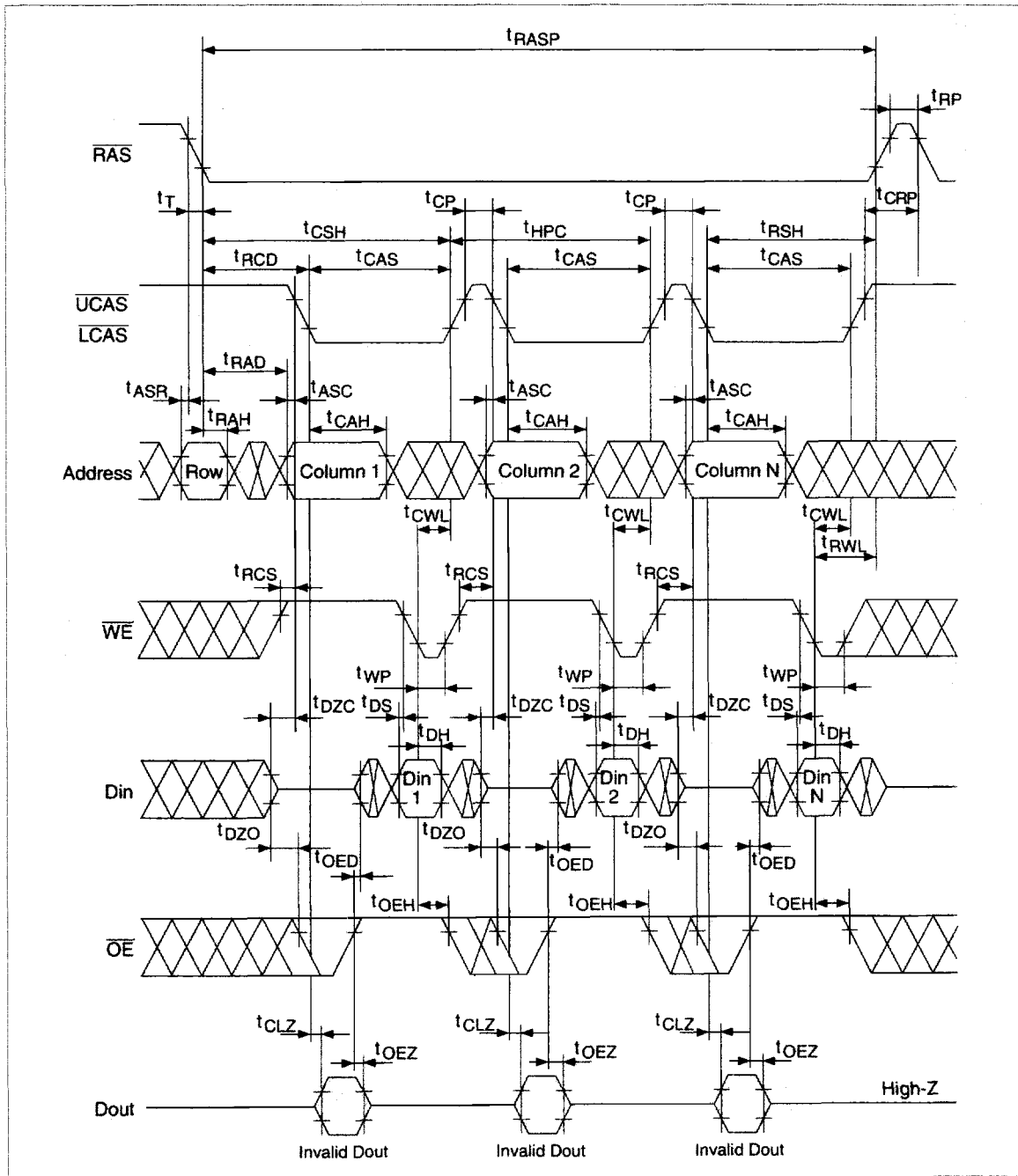

HM51W16165A Series, HM51W18165A Series

EDO Page Mode Read-Modify-Write Cycle*18

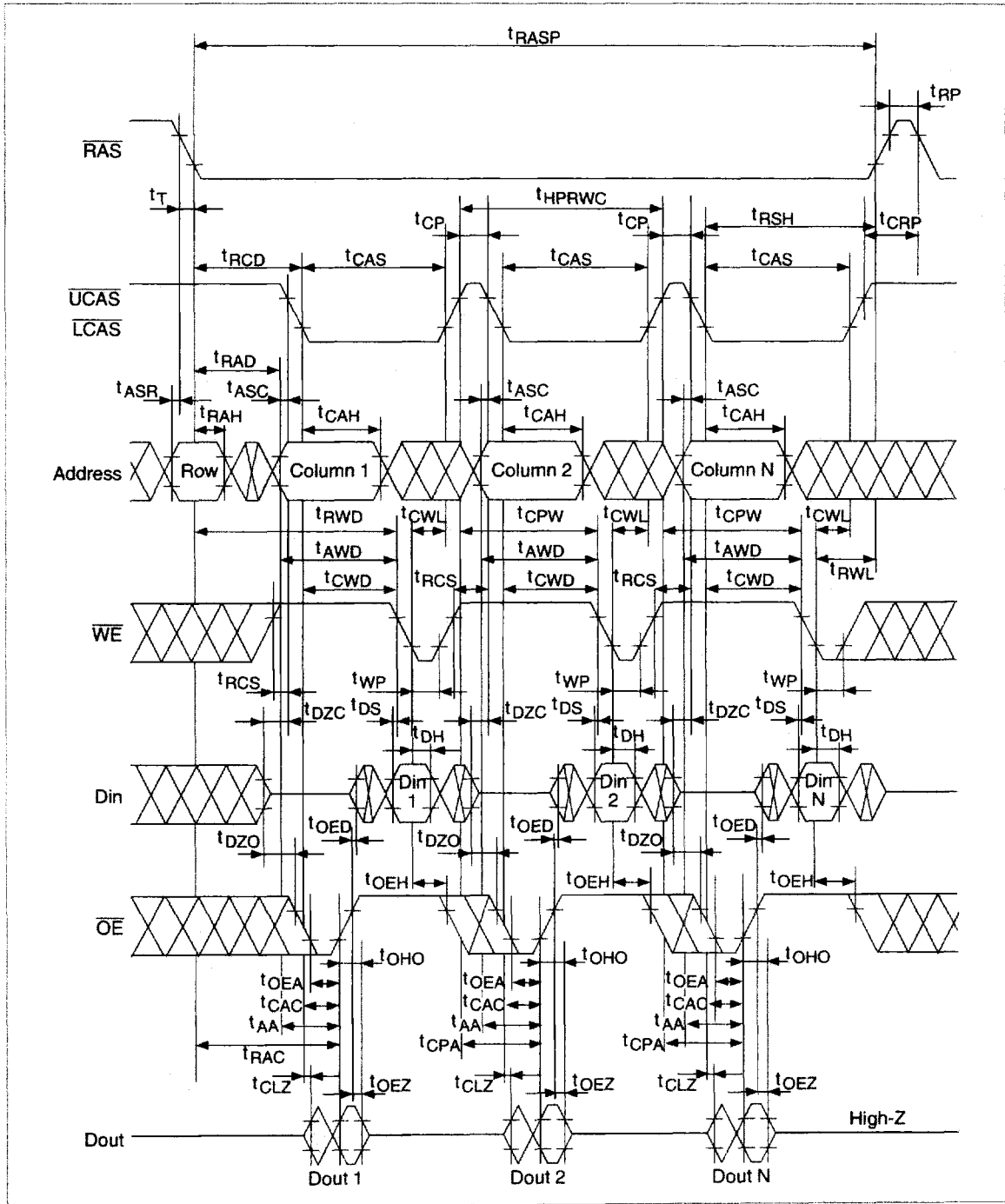

HM51W16165A Series, HM51W18165A Series

EDO Page Mode Mix Cycle (1)

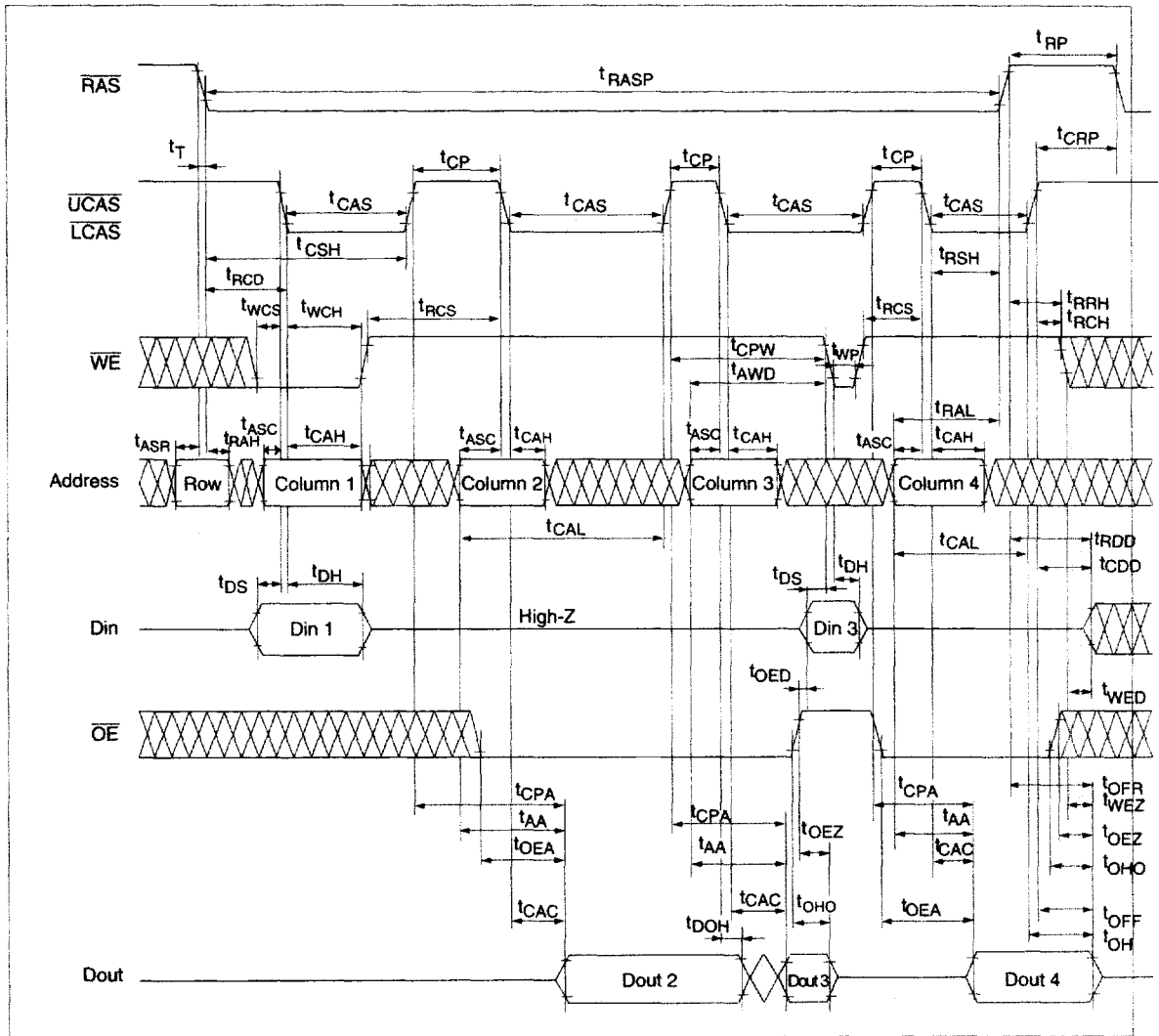

HITACHI

HM51W16165A Series, HM51W18165A Series

EDO Page Mode Mix Cycle (2)

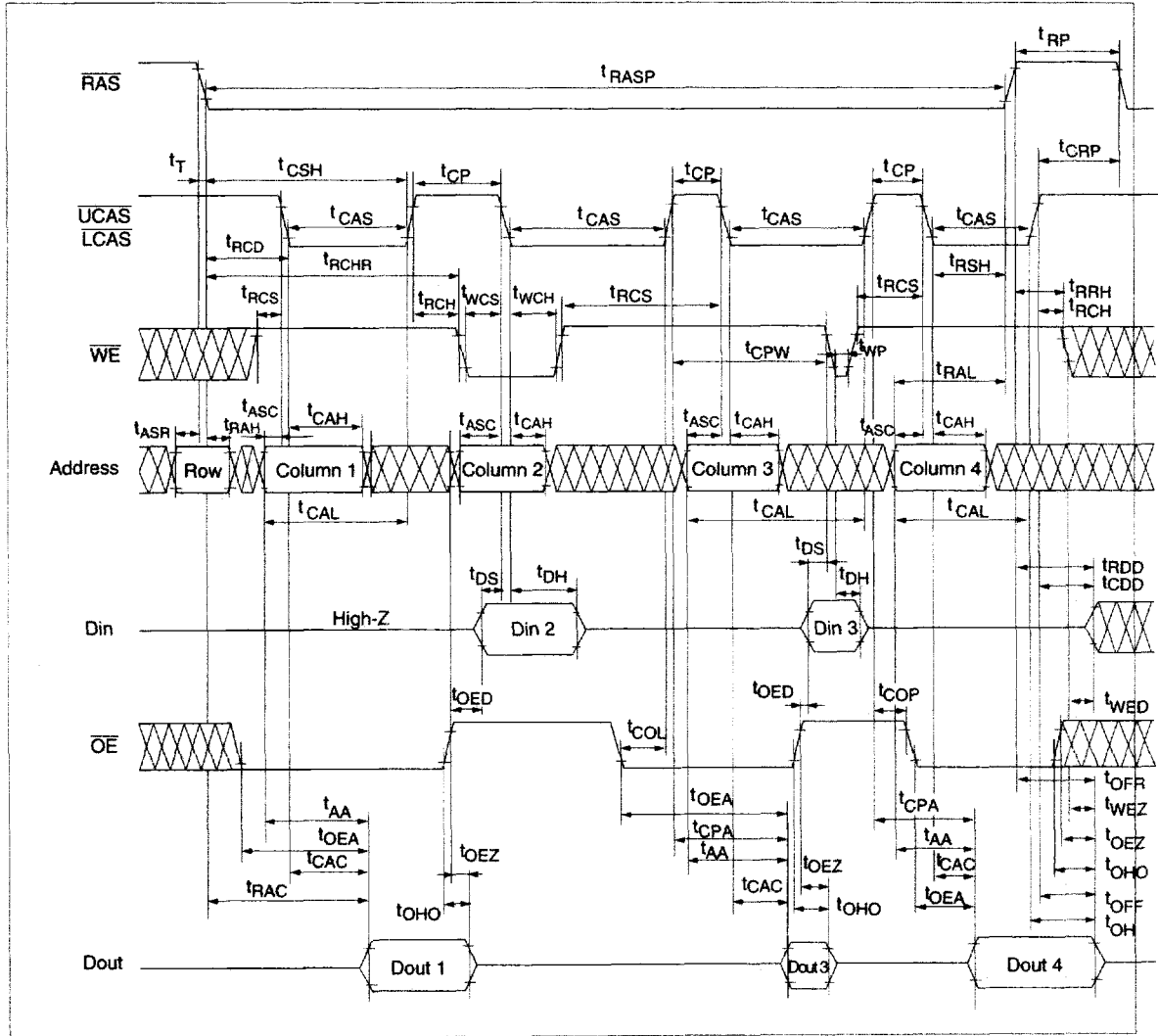

HM51W16165A Series, HM51W18165A Series

Self Refresh Cycle (L-version)*28, 29, 30, 31

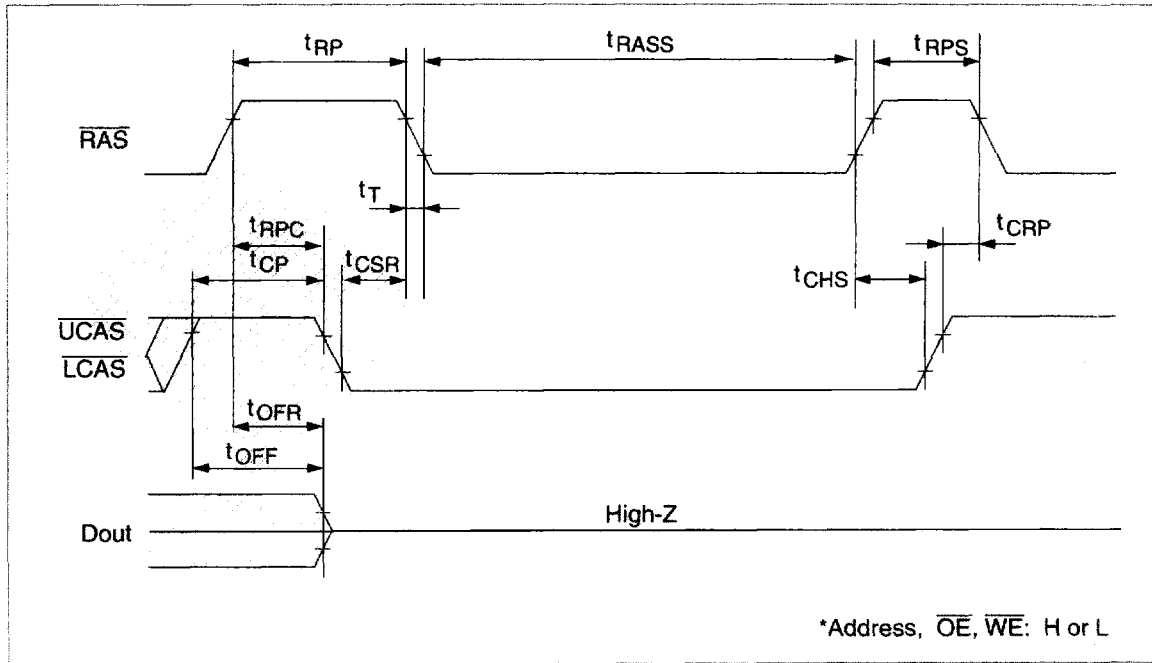

HM51W16165A Series, HM51W18165A Series

Package Dimensions

HM51W16165AJ/ALJ Series

HM51W18165AJ/ALJ Series (CP-42D)

Unit: mm

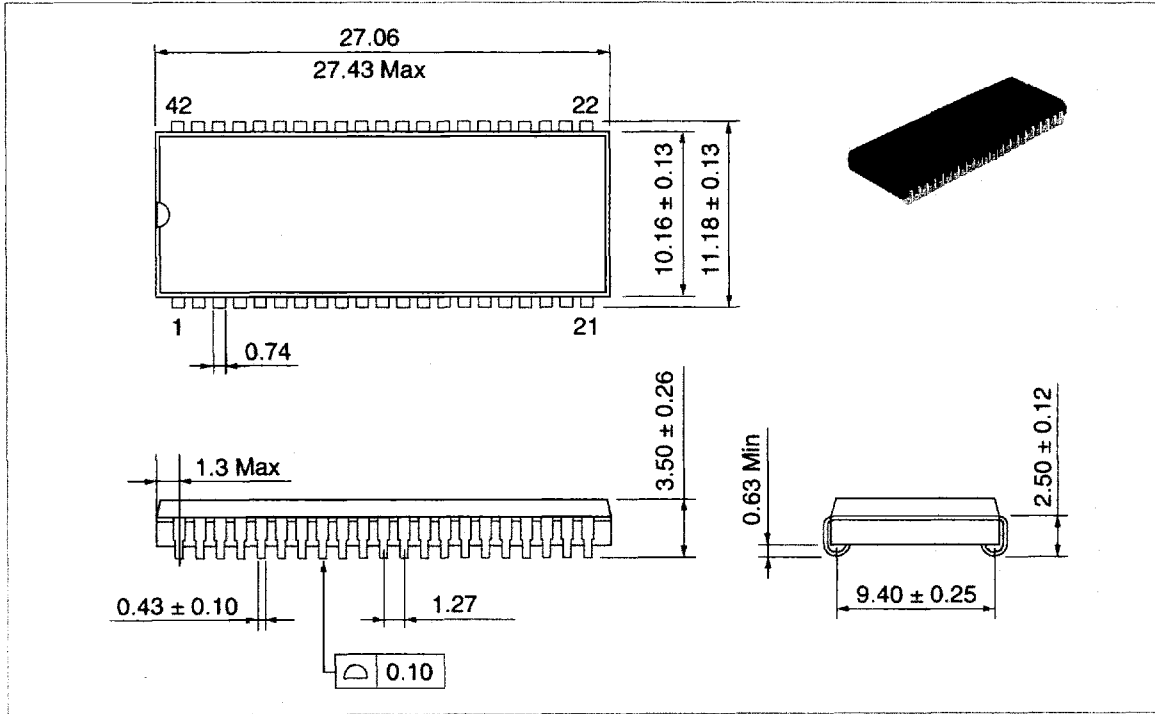

HM51W16165A Series, HM51W18165A Series

HM51W16165ATT/ALTT Series

HM51W18165ATT/ALTT Series (TTP-50/

Unit: mm

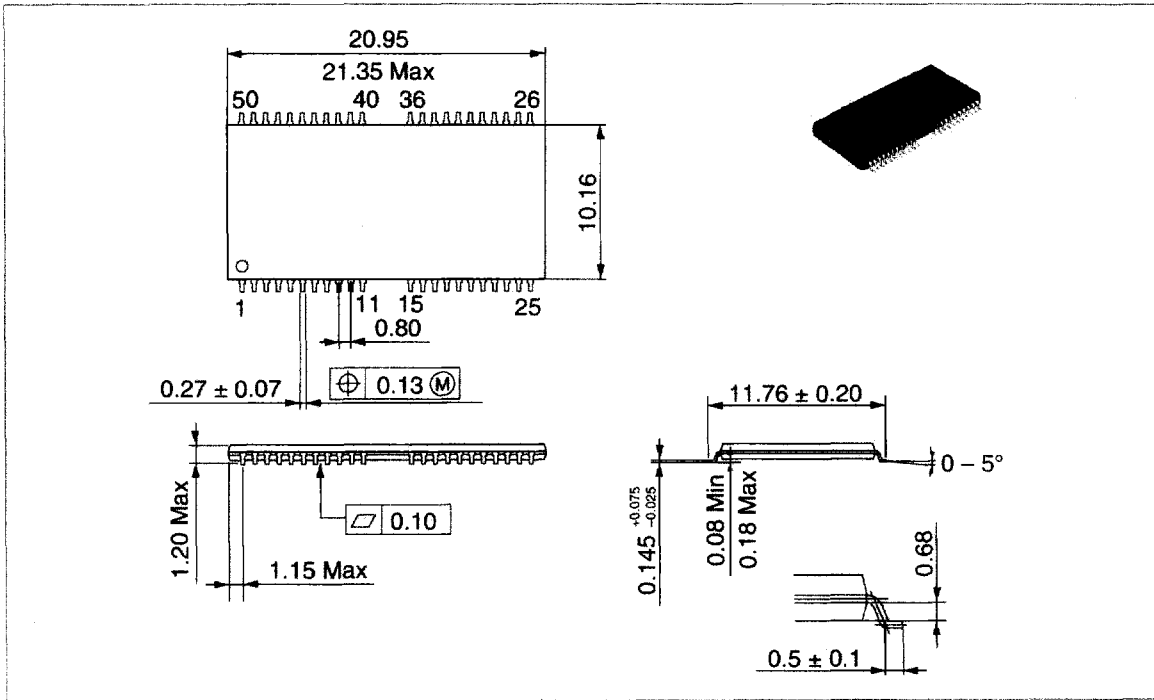

HM51W16165A Series, HM51W18165A Series

When using this document, keep the following in mind:

1. This document may, wholly or partially, be subject to change without notice.
2. All rights are reserved: No one is permitted to reproduce or duplicate, in any form, the whole or part of this document without Hitachi's permission.
3. Hitachi will not be held responsible for any damage to the user that may result from accidents or any other reasons during operation of the user's unit according to this document.
4. Circuitry and other examples described herein are meant merely to indicate the characteristics and performance of Hitachi's semiconductor products. Hitachi assumes no responsibility for any intellectual property claims or other problems that may result from applications based on the examples described herein.
5. No license is granted by implication or otherwise under any patents or other rights of any third party or Hitachi, Ltd.
6. **MEDICAL APPLICATIONS:** Hitachi's products are not authorized for use in **MEDICAL APPLICATIONS** without the written consent of the appropriate officer of Hitachi's sales company. Such use includes, but is not limited to, use in life support systems. Buyers of Hitachi's products are requested to notify the relevant Hitachi sales offices when planning to use the products in **MEDICAL APPLICATIONS**.

HITACHI

Hitachi, Ltd.

Semiconductor & IC Div.
Nippon Bldg., 2-6-2, Ohte-machi, Chiyoda-ku, Tokyo 100, Japan
Tel: Tokyo (03) 3270-2111
Fax: (03) 3270-5109

For further information write to:

Hitachi America, Ltd.
Semiconductor & IC Div.
2000 Sierra Point Parkway
Brisbane, CA. 94005-1835
U S A
Tel: 415-589-8300
Fax: 415-583-4207

Hitachi Europe GmbH
Electronic Components Group
Continental Europe
Dornacher Straße 3
D-85622 Feldkirchen
München
Tel: 089-9 91 80-0
Fax: 089-9 29 30 00

Hitachi Europe Ltd.
Electronic Components Div.
Northern Europe Headquarters
Whitebrook Park
Lower Cookham Road
Maidenhead
Berkshire SL6 8YA
United Kingdom
Tel: 0628-585000
Fax: 0628-778322

Hitachi Asia Pte. Ltd.
16 Collyer Quay #20-00
Hitachi Tower
Singapore 0104
Tel: 535-2100
Fax: 535-1533

Hitachi Asia (Hong Kong) Ltd.
Unit 706, North Tower,
World Finance Centre,
Harbour City, Canton Road
Tsim Sha Tsui, Kowloon
Hong Kong
Tel: 27359218
Fax: 27306071

HM51W16165A Series, HM51W18165A Series

Revision Record

Rev.	Date	Contents of Modification	Drawn by	Approved by
0.0	Jul. 20, 1995	Initial issue	M. Mishima	H. Iijima
1.0	Dec. 15, 1995	Change of format Change of format of truth table Recommended DC Operating condition Addition of note 2 DC Characteristics I_{CC2} (L-version) max: 0.1/0.1/0.1 mA to 150/150/150 μ A I_{CC11} max: 200/200/200 μ A to 250/250/250 μ A Addition of note 4 AC Characteristics t_{RCD} max: 38/45/53 ns to 45/52/60 ns t_{RCH} min: 5/5/5 ns to 0/0/0 ns t_{RRH} min: 0/0/0 ns to 5/5/5 ns t_{RWD} min: 82/95/107 ns to 79/92/104 ns t_{CWD} min: 37/43/47 ns to 34/40/44 ns t_{AWD} min: 52/60/67 ns to 49/57/64 ns t_{DOH} min: 5/5/5 ns to 3/3/3 ns Deletion of note 3 Change of note 10, 11 Timing Waveforms Correct errors Change of Package Dimensions: CP-42D Package overhang max: 1.265 mm to 1.3 mm	M. Mishima	K. Hayakawa
2.0	Jul. 2, 1996	Unification of HM51W16165A and HM51W18165A Series Change format Addition of HM51W18165A-6 Series Pin Descriptions Addition of Row/Refresh address and Column address to address input AC Characteristics t_{RWC} min: 149/175/199 ns to 136/161/185 ns t_{HPRWC} min: 79/90/99 ns to 68/79/88 ns Addition of note 27 Notes concerning $2\overline{CAS}$ control Addition of note 4 Timing waveforms Deletion of note: $t_{OEH} \geq t_{CWE}$ Deletion of notes for RAS-only refresh cycle		