

SN54HC354, SN74HC354

8-LINE TO 1-LINE DATA SELECTORS/MULTIPLEXERS/ TRANSPARENT REGISTERS WITH 3-STATE OUTPUTS

D2684, DECEMBER 1982—REVISED SEPTEMBER 1987

- Transparent Latches on Data Select Inputs
- Transparent Data Registers
- High-Current 3-State Outputs Can Drive Up to 15 LSTTL Loads
- Complementary Outputs
- Package Options: Plastic and Ceramic DIPs, Plastic Small-Outline Packages, and Ceramic Chip Carriers
- Dependable Texas Instruments Quality and Reliability

SN54HC354 . . . J PACKAGE
SN74HC354 . . . DW OR N PACKAGE

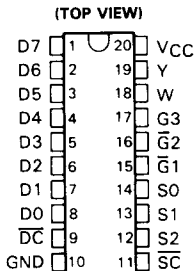

SN54HC354 . . . FK PACKAGE

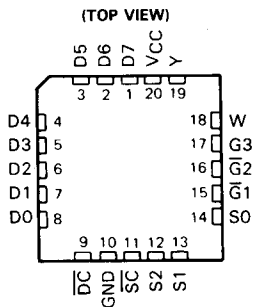

2

HCMOS Devices

description

These monolithic data selectors/multiplexers contain full on-chip binary decoding to select one of eight data sources. The data-select is stored in transparent latches that are enabled by a low level on pin 11, \overline{SC} . A similar enable for data is obtained by a low level on pin 8, \overline{DC} .

The SN54HC354 is characterized for operation over the full military temperature range of -55°C to 125°C . The SN74HC354 is characterized for operation from -40°C to 85°C .

logic symbol†

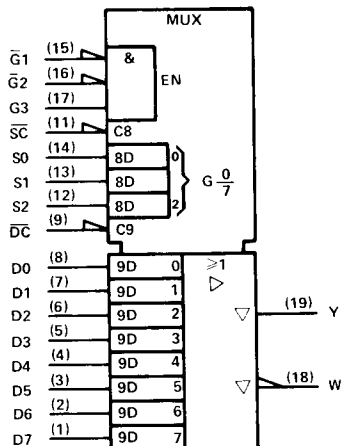

† This symbol is in accordance with ANSI/IEEE Std 91-1984 and IEC Publication 617-12.

SN54HC354, SN74HC354
**8-LINE TO 1-LINE DATA SELECTORS/MULTIPLEXERS/
 TRANSPARENT REGISTERS WITH 3-STATE OUTPUTS**

logic diagram (positive logic)

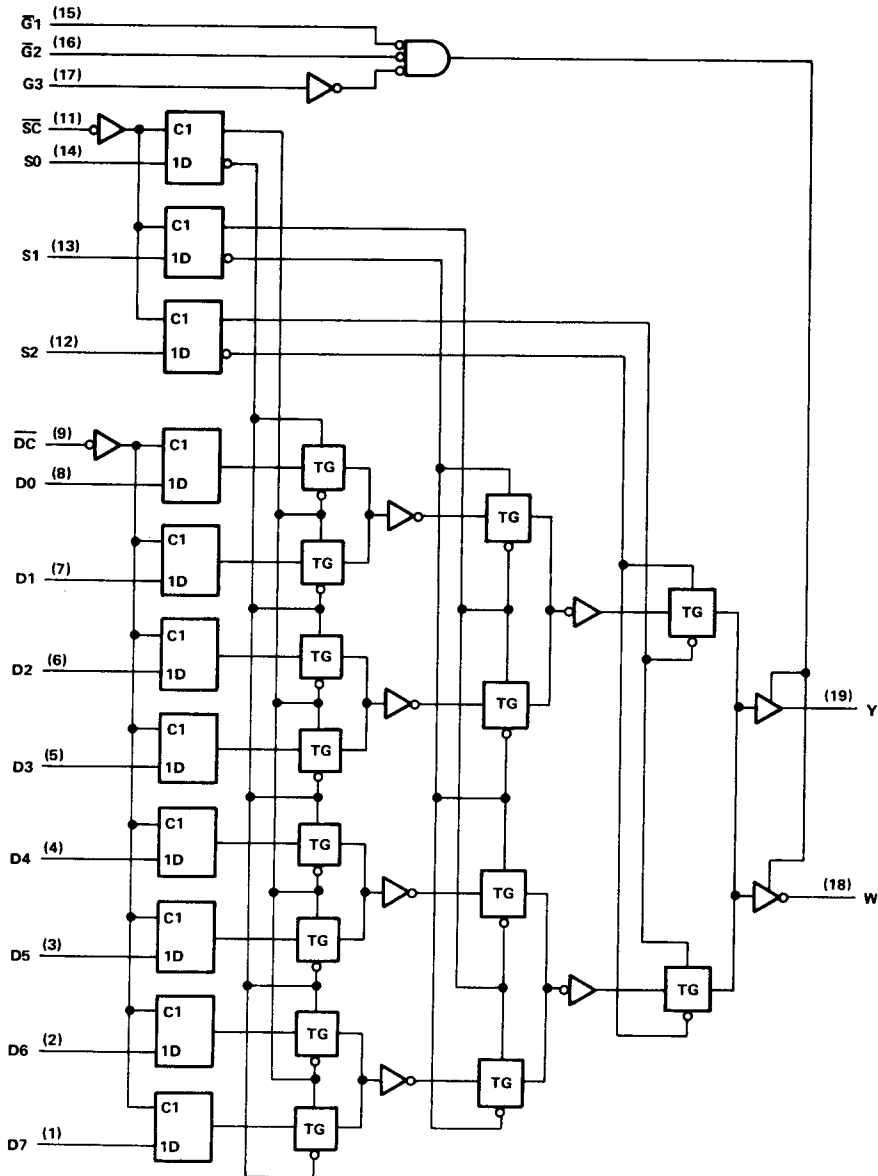

2

HCMOS Devices

SN54HC354, SN74HC354
8-LINE TO 1-LINE DATA SELECTORS/MULTIPLEXERS/
TRANSPARENT REGISTERS WITH 3-STATE OUTPUTS

FUNCTION TABLE

SELECT†			INPUTS				OUTPUTS	
			DATA CONTROL	OUTPUT ENABLES				
S2	S1	S0	\overline{DC}	$\overline{G1}$	$\overline{G2}$	G3	W	Y
X	X	X	X	H	X	X	Z	Z
X	X	X	X	X	H	X	Z	Z
X	X	X	X	X	X	L	Z	Z
L	L	L	L	L	L	H	$\overline{D0}$	D0
L	L	L	H	L	L	H	$\overline{D0_n}$	D0 _n
L	L	H	L	L	L	H	$\overline{D1}$	D1
L	L	H	H	L	L	H	$\overline{D1_n}$	D1 _n
L	H	L	L	L	L	H	$\overline{D2}$	D2
L	H	L	H	L	L	H	$\overline{D2_n}$	D2 _n
L	H	H	L	L	L	H	$\overline{D3}$	D3
L	H	H	H	L	L	H	$\overline{D3_n}$	D3 _n
H	L	L	L	L	L	H	$\overline{D4}$	D4
H	L	L	H	L	L	H	$\overline{D4_n}$	D4 _n
H	L	H	L	L	L	H	$\overline{D5}$	D5
H	L	H	H	L	L	H	$\overline{D5_n}$	D5 _n
H	H	L	L	L	L	H	$\overline{D6}$	D6
H	H	L	H	L	L	H	$\overline{D6_n}$	D6 _n
H	H	H	L	L	L	H	$\overline{D7}$	D7
H	H	H	H	L	L	H	$\overline{D7_n}$	D7 _n

H = high level (steady state)

L = low level (steady state)

X = irrelevant (any input, including transitions)

Z = high-impedance state (off state)

† = transition from low to high level

D0 . . . D7 = the level of steady-state inputs at inputs D0 through D7, respectively

D0_n . . . D7_n = the level of steady state inputs at inputs D0 through D7, respectively, before the most recent low-to-high transition of data control

† This column shows the input address setup with \overline{SC} low.

SN54HC354, SN74HC354

8-LINE TO 1-LINE DATA SELECTORS/MULTIPLEXERS/ TRANSPARENT REGISTERS WITH 3-STATE OUTPUTS

absolute maximum ratings over operating free-air temperature range†

Supply voltage, V_{CC}	-0.5 V to 7 V
Input clamp current, I_{IK} ($V_I < 0$ or $V_I > V_{CC}$)	± 20 mA
Output clamp current, I_{OK} ($V_O < 0$ or $V_O > V_{CC}$)	± 20 mA
Continuous output current, I_O ($V_O = 0$ to V_{CC})	± 35 mA
Continuous current through V_{CC} or GND pins	± 70 mA
Lead temperature 1,6 mm (1/16 in) from case for 60 s: FK or J package	300°C
Lead temperature 1,6 mm (1/16 in) from case for 10 s: DW or N package	260°C
Storage temperature range	-65°C to 150°C

†Stresses beyond those listed under "absolute maximum ratings" may cause permanent damage to the device. These are stress ratings only, and functional operation of the device at these or any other conditions beyond those indicated under "recommended operating conditions" is not implied. Exposure to absolute-maximum-rated conditions for extended periods may affect device reliability.

recommended operating conditions

		SN54HC354			SN74HC354			UNIT
		MIN	NOM	MAX	MIN	NOM	MAX	
V_{CC}	Supply voltage	2	5	6	2	5	6	V
V_{IH}	High-level input voltage	$V_{CC} = 2$ V	1.5		1.5		V	
		$V_{CC} = 4.5$ V	3.15		3.15			
		$V_{CC} = 6$ V	4.2		4.2			
V_{IL}	Low-level input voltage	$V_{CC} = 2$ V	0	0.3	0	0.3	V	
		$V_{CC} = 4.5$ V	0	0.9	0	0.9		
		$V_{CC} = 6$ V	0	1.2	0	1.2		
V_I	Input voltage	0	V_{CC}		0	V_{CC}		V
V_O	Output voltage	0	V_{CC}		0	V_{CC}		V
t_t	Input transition (rise and fall) times	$V_{CC} = 2$ V	0	1000	0	1000	ns	
		$V_{CC} = 4.5$ V	0	500	0	500		
		$V_{CC} = 6$ V	0	400	0	400		
T_A	Operating free-air temperature	-55	125		-40	85		°C

electrical characteristics over recommended operating free-air temperature range (unless otherwise noted)

PARAMETER	TEST CONDITIONS	V_{CC}	$T_A = 25^\circ\text{C}$			SN54HC354		SN74HC354		UNIT
			MIN	TYP	MAX	MIN	MAX	MIN	MAX	
V_{OH}	$V_I = V_{IH}$ or V_{IL} , $I_{OH} = -20 \mu\text{A}$	2 V	1.9	1.998		1.9	1.9	V		
		4.5 V	4.4	4.499		4.4	4.4			
		6 V	5.9	5.999		5.9	5.9			
	4.5 V	3.98	4.30		3.7	3.84				
V_{OL}	$V_I = V_{IH}$ or V_{IL} , $I_{OH} = -6 \text{ mA}$	6 V	5.48	5.80		5.2	5.34	V		
		2 V	0.002	0.1		0.1	0.1			
		4.5 V	0.001	0.1		0.1	0.1			
	6 V	0.001	0.1		0.1	0.1				
V_{OL}	$V_I = V_{IH}$ or V_{IL} , $I_{OL} = 20 \mu\text{A}$	4.5 V	0.17	0.26		0.4	0.33			
		6 V	0.15	0.26		0.4	0.33			
I_I	$V_I = V_{CC}$ or 0	6 V	± 0.1	± 100		± 1000	± 1000	nA		
I_{OZ}	$V_O = V_{CC}$ or 0	6 V	± 0.01	± 0.5		± 10	± 5	μA		
I_{CC}	$V_I = V_{CC}$ or 0, $I_O = 0$	6 V	8			160	80	μA		
C_i		2 to 6 V	3	10		10	10	pF		

SN54HC354, SN74HC354 8-LINE TO 1-LINE DATA SELECTORS/MULTIPLEXERS/ TRANSPARENT REGISTERS WITH 3-STATE OUTPUTS

timing requirements over recommended operating free-air temperature range (unless otherwise noted)

		VCC	T _A = 25°C			SN54HC354		SN74HC354		UNIT
			MIN	MAX		MIN	MAX	MIN	MAX	
t _w	Pulse duration	2 V	80		120		100		ns	
		4.5 V	16		24		20			
		6 V	14		20		17			
	$\overline{\text{DC}}$ low	2 V	80		120		100			
		4.5 V	16		24		20			
		6 V	14		20		17			
t _{su}	Data before $\overline{\text{DC}}\dagger$	2 V	75		110		95		ns	
		4.5 V	15		22		19			
		6 V	13		19		16			
	S0 thru S2 before $\overline{\text{SC}}\dagger$	2 V	75		110		95			
		4.5 V	15		22		19			
		6 V	13		19		16			
t _h	Data after $\overline{\text{DC}}\dagger$	2 V	5		5		5		ns	
		4.5 V	5		5		5			
		6 V	5		5		5			
	S0 thru S2 after $\overline{\text{SC}}\dagger$	2 V	5		5		5			
		4.5 V	5		5		5			
		6 V	5		5		5			

2

HCMOS Devices

switching characteristics over recommended operating free-air temperature range (unless otherwise noted), C_L = 50 pF (see Note 1)

PARAMETER	FROM (INPUT)	TO (OUTPUT)	VCC	T _A = 25°C			SN54HC354		SN74HC354		UNIT
				MIN	TYP	MAX	MIN	MAX	MIN	MAX	
t _{pd}	Any D	W or Y	2 V		90	235	352		295		ns
			4.5 V		29	47	71		59		
			6 V		25	40	60		50		
t _{pd}	$\overline{\text{DC}}$	W or Y	2 V		115	270	405		337		ns
			4.5 V		40	54	81		68		
			6 V		32	46	69		58		
t _{pd}	S0, S1, or S2	W or Y	2 V		120	285	427		355		ns
			4.5 V		42	57	86		71		
			6 V		34	48	72		60		
t _{pd}	$\overline{\text{SC}}$	W or Y	2 V		120	300	450		375		ns
			4.5 V		45	60	90		75		
			6 V		36	51	77		64		
t _{en}	$\overline{\text{G}}1, \overline{\text{G}}2, \text{ or } \overline{\text{G}}3$	W or Y	2 V		50	125	188		155		ns
			4.5 V		18	25	38		31		
			6 V		15	21	32		26		
t _{dis}	$\overline{\text{G}}1, \overline{\text{G}}2, \text{ or } \overline{\text{G}}3$	W or Y	2 V		68	165	248		205		ns
			4.5 V		24	33	50		41		
			6 V		20	28	43		35		
t _t		W or Y	2 V		28	60	90		75		ns
			4.5 V		8	12	18		15		
			6 V		6	10	15		13		

C _{pd}	Power dissipation capacitance	No load, T _A = 25°C	100 pF typ
-----------------	-------------------------------	--------------------------------	------------

NOTE 1: Load circuits and voltage waveforms are shown in Section 1.

SN54HC354, SN74HC354
8-LINE TO 1-LINE DATA SELECTORS/MULTIPLEXERS/
TRANSPARENT REGISTERS WITH 3-STATE OUTPUTS

switching characteristics over recommended operating free-air temperature range (unless otherwise noted), $C_L = 150$ pF (see Note 1)

PARAMETER	FROM (INPUT)	TO (OUTPUT)	V _{CC}	T _A = 25°C			SN54HC354		SN74HC354		UNIT
				MIN	TYP	MAX	MIN	MAX	MIN	MAX	
t _{pd}	Any D	W or Y	2 V	100	275		412		344	ns	
			4.5 V	40	55		83		69		
			6 V	32	46		69		59		
t _{pd}	\overline{DC}	W or Y	2 V	125	310		465		387	ns	
			4.5 V	46	62		93		78		
			6 V	38	52		78		66		
t _{pd}	S0, S1, or S2	W or Y	2 V	130	325		488		405	ns	
			4.5 V	50	65		98		81		
			6 V	40	55		82		69		
t _{pd}	\overline{SC}	W or Y	2 V	110	340		510		425	ns	
			4.5 V	52	68		102		85		
			6 V	42	58		87		72		
t _{en}	$\overline{G1}, \overline{G2},$ or G3	W or Y	2 V	60	165		248		205	ns	
			4.5 V	25	33		50		41		
			6 V	21	28		42		35		
t _t		W or Y	2 V	37	210		315		265	ns	
			4.5 V	12	42		63		53		
			6 V	10	36		53		45		

NOTE 1: Load circuits and voltage waveforms are shown in Section 1.

2

HCMOS Devices