

# 412/D-SUB HD 5.34mm Type

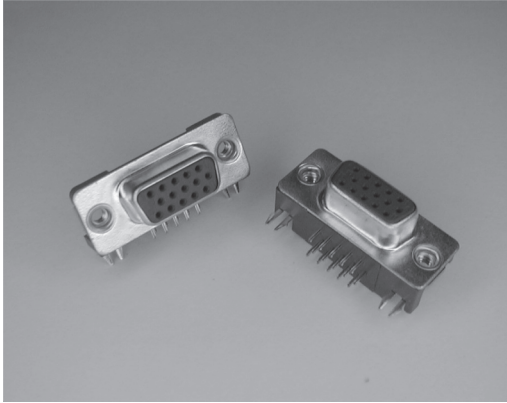

## MATERIAL:

1. INSULATOR : PBT + 30% GLASS FIBER (UL 94V-0).
2. CONTACT : BRASS.
3. CONTACT PLATED : GOLD-FLASH OVER NICKEL.
4. DIP AREA PLATED : TIN.
5. SHELL : STEEL WITH NICKEL PLATED.

## SPECIFICATION:

1. DIELECTRIC STRENGTH : 1000V FOR ONE MINUTE.
2. INSULATION RESISTANCE : 1000 MEGOHMS MIN. AT 500V DC.
3. CONTACT RESISTANCE : 20 MILLIOHMS MAX.
4. TEMPERATURE : -55°C TO +105°C.
5. RATED CURRENT : 5 AMPS.

## NOTE :

1. PC99 PANTONE COLOR CODE : BLUE : 661C.

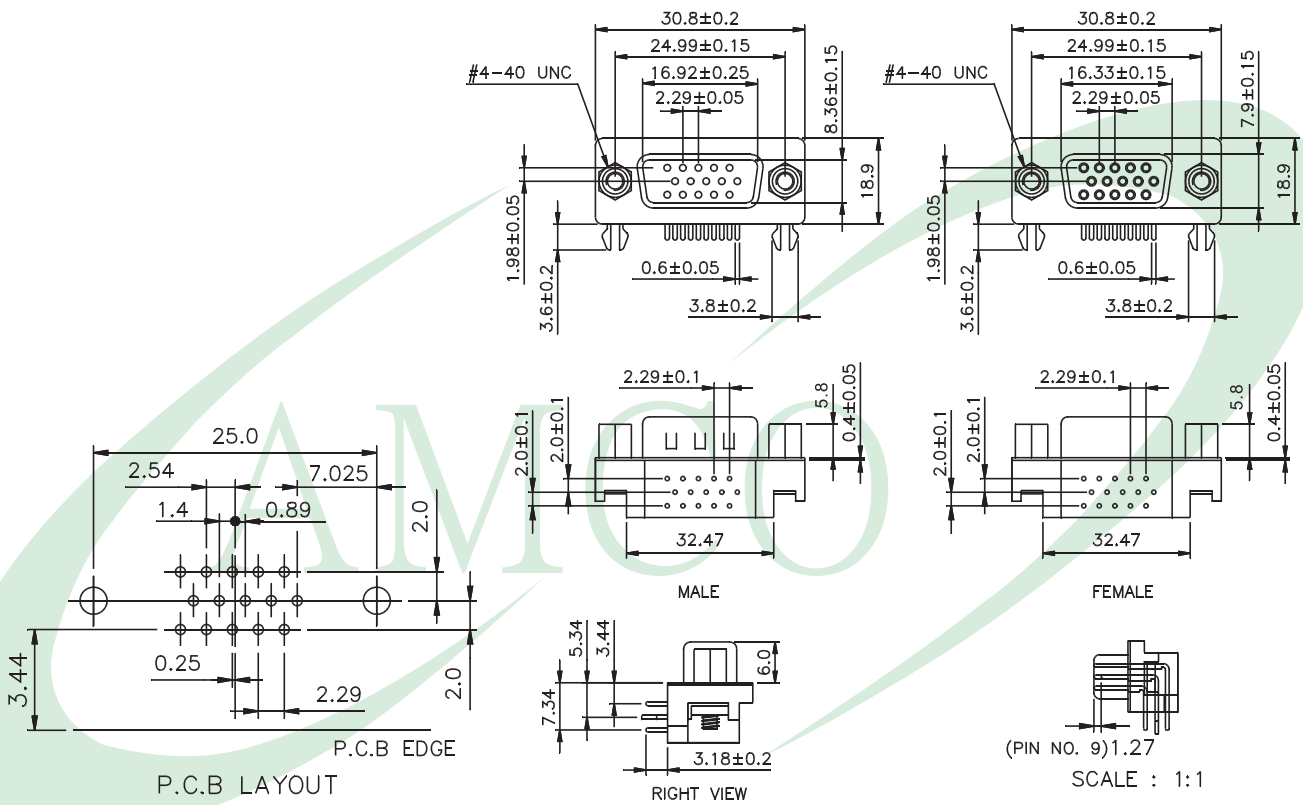

## 412. D-SUB

Series No.

1	2	3	4
<b>4</b>	<b>1</b>	<b>2</b>	

HIGH DENSITY R/A TYPE  
5.34mm FOOT PRINT

No. of Contacts

5	6
<b>1</b>	<b>5</b>

15

26

44

62

Contact MOUNTING

Type Type

7	8
<b>M</b>	<b>C</b>

M: MALE A: Rivet

F: FEMALE Type

B: With Jack

C: Rivet With

Jack Screw

D: Rivet Add

Jack Screw

Shell

Plated

9
<b>N</b>

N: NICKEL

T: TIN

Z: ZINC

Contact Plated

10	11
<b>S</b>	<b>1</b>

T1: TIN

G1: Gold Flash

G2: 3u" Gold

G3: 5u" Gold

G4: 10u" Gold

G5: 15u" Gold

G6: 30u" Gold

(G: Full Gold)(S: Selective Gold)

Plastic

Color

12
<b>U</b>

B: Black

U: Blue

S4: 10u" Gold

S5: 15u" Gold

S6: 30u" Gold

(G: Full Gold)(S: Selective Gold)

Branding

13
<b>A</b>

A: Amco Mark

N: No Mark