

# SN54HC139, SN74HC139 DUAL 2-LINE TO 4-LINE DECODERS/DEMULTIPLEXERS

D2684, DECEMBER 1982 - REVISED SEPTEMBER 1987

- Designed Specifically for High-Speed Memory Decoders and Data Transmission Systems
- Incorporates 2 Enable Inputs to Simplify Cascading and/or Data Reception
- Package Options Include Plastic "Small Outline" Packages, Ceramic Chip Carriers, and Standard Plastic and Ceramic 300-mil DIPs
- Dependable Texas Instruments Quality and Reliability

## description

The 'HC139 circuit is designed to be used in high-performance memory-decoding or data-routing applications requiring very short propagation delay times. In high-performance memory systems, this decoder can be used to minimize the effects of system decoding. When employed with high-speed memories utilizing a fast enable circuit, the delay times of this decoder and the enable time of the memory are usually less than the typical access time of the memory. This means that the effective system delay introduced by the decoder is negligible.

The 'HC139 is comprised of two individual two-line to four-line decoders in a single package. The active-low enable input can be used as a data line in demultiplexing applications. These decoders/demultiplexers feature fully buffered outputs, each of which represents only one normalized load to its driving circuit.

The SN54HC139 is characterized for operation over the full military temperature range of -55°C to 125°C. The SN74HC139 is characterized for operation from -40°C to 85°C.

SN54HC139 . . . J PACKAGE  
SN74HC139 . . . DW OR N PACKAGE  
(TOP VIEW)

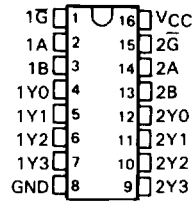

SN54HC139 . . . FK PACKAGE  
(TOP VIEW)

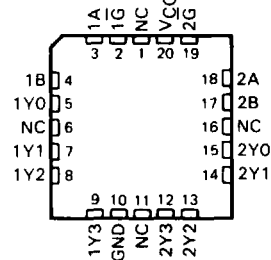

NC - No internal connection

FUNCTION TABLE

INPUTS		OUTPUTS			
ENABLE	SELECT	Y0	Y1	Y2	Y3
$\bar{G}$	B A				
H	X X	H	H	H	H
L	L L	L	H	H	H
L	L H	H	L	H	H
L	H L	H	H	L	H
L	H H	H	H	H	L

2

HCMOS Devices

PRODUCTION DATA documents contain information current as of publication date. Products conform to specifications per the terms of Texas Instruments standard warranty. Production processing does not necessarily include testing of all parameters.

**TEXAS INSTRUMENTS**

POST OFFICE BOX 655012 • DALLAS, TEXAS 75265

Copyright © 1982, Texas Instruments Incorporated

2-183

**SN54HC139, SN74HC139**  
**DUAL 2-LINE TO 4-LINE DECODERS/DEMULTIPLEXERS**

**logic symbols (alternatives)†**

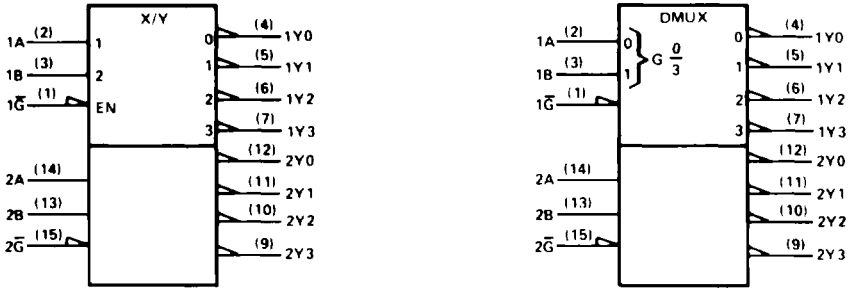

† These symbols are in accordance with ANSI/IEEE Std 91-1984 and IEC Publication 617-12.

**logic diagram (positive logic)**

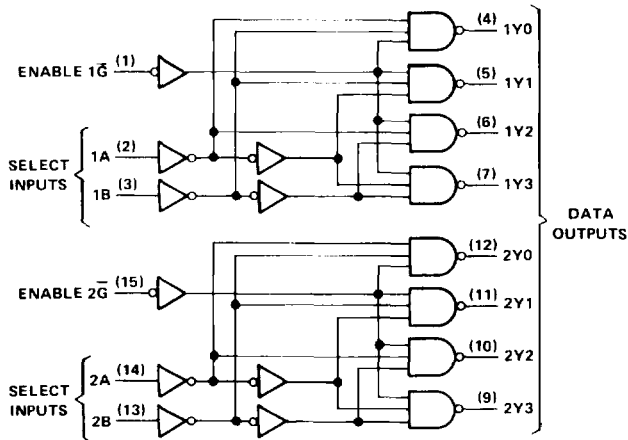

Pin numbers shown are for DW, J, and N packages.

**2**  
**HC MOS Devices**

# SN54HC139, SN74HC139 DUAL 2-LINE TO 4-LINE DECODERS/DEMULTIPLEXERS

## absolute maximum ratings over operating free-air temperature†

Supply voltage, $V_{CC}$ .....	-0.5 V to 7 V
Input clamp current, $I_{IK}$ ( $V_I < 0$ or $V_I > V_{CC}$ ) .....	$\pm 20$ mA
Output clamp current, $I_{OK}$ ( $V_O < 0$ or $V_O > V_{CC}$ ) .....	$\pm 20$ mA
Continuous output current, $I_O$ ( $V_O = 0$ to $V_{CC}$ ) .....	$\pm 25$ mA
Continuous current through $V_{CC}$ or GND pins .....	$\pm 50$ mA
Lead temperature 1,6 mm (1/16 in) from case for 60 s: FK or J package .....	300°C
Lead temperature 1,6 mm (1/16 in) from case for 10 s: D or N package .....	260°C
Storage temperature range .....	-65°C to 150°C

† Stresses beyond those listed under "absolute maximum ratings" may cause permanent damage to the device. These are stress ratings only, and functional operation of the device at these or any other conditions beyond those indicated under "recommended operating conditions" is not implied. Exposure to absolute-maximum-rated conditions for extended periods may affect device reliability.

## recommended operating conditions

		SN54HC139			SN74HC139			UNIT
		MIN	NOM	MAX	MIN	NOM	MAX	
$V_{CC}$ Supply voltage		2	5	6	2	5	6	V
$V_{IH}$ High-level input voltage	$V_{CC} = 2$ V	1.5			1.5			V
	$V_{CC} = 4.5$ V	3.15			3.15			
	$V_{CC} = 6$ V	4.2			4.2			
$V_{IL}$ Low-level input voltage	$V_{CC} = 2$ V	0	0.3		0	0.3		V
	$V_{CC} = 4.5$ V	0	0.9		0	0.9		
	$V_{CC} = 6$ V	0	1.2		0	1.2		
$V_I$ Input voltage		0	$V_{CC}$		0	$V_{CC}$		V
$V_O$ Output voltage		0	$V_{CC}$		0	$V_{CC}$		V
$t_t$ Input transition (rise and fall) times	$V_{CC} = 2$ V	0	1000		0	1000		ns
	$V_{CC} = 4.5$ V	0	500		0	500		
	$V_{CC} = 6$ V	0	400		0	400		
$T_A$ Operating free-air temperature		-55	125		-40	85		°C

## electrical characteristics over recommended operating free-air temperature range (unless otherwise noted)

PARAMETER	TEST CONDITIONS	$V_{CC}$	$T_A = 25^\circ\text{C}$			SN54HC139		SN74HC139		UNIT
			MIN	TYP	MAX	MIN	MAX	MIN	MAX	
$V_{OH}$	$V_I = V_{IH}$ or $V_{IL}$ , $I_{OH} = 20 \mu\text{A}$	2 V	1.9	1.998		1.9	1.9		V	
		4.5 V	4.4	4.499		4.4	4.4			
		6 V	5.9	5.999		5.9	5.9			
	4.5 V	3.98	4.30		3.7	3.84				
	$V_I = V_{IH}$ or $V_{IL}$ , $I_{OH} = 5.2 \text{ mA}$	6 V	5.48	5.80		5.2	5.34			
$V_{OL}$	$V_I = V_{IH}$ or $V_{IL}$ , $I_{OL} = 20 \mu\text{A}$	2 V		0.002	0.1		0.1	0.1	V	
		4.5 V		0.001	0.1		0.1	0.1		
		6 V		0.001	0.1		0.1	0.1		
	4.5 V		0.17	0.26		0.4	0.33			
	$V_I = V_{IH}$ or $V_{IL}$ , $I_{OL} = 5.2 \text{ mA}$	6 V		0.15	0.26		0.4	0.33		
$I_I$	$V_I = V_{CC}$ or 0	6 V		$\pm 0.1$	$\pm 100$		$\pm 1000$	$\pm 1000$	nA	
$I_{CC}$	$V_I = V_{CC}$ or 0, $I_O = 0$	6 V			8		160	80	$\mu\text{A}$	
$C_i$		2 to 6 V		3	10		10	10	pF	

**SN54HC139, SN74HC139**  
**DUAL 2-LINE TO 4-LINE DECODERS/DEMULTIPLEXERS**

switching characteristics over recommended operating free-air temperature range (unless otherwise noted),  $C_L = 50$  pF (see Note 1)

PARAMETER	FROM (INPUT)	TO (OUTPUT)	VCC	T <sub>A</sub> = 25°C			SN54HC139		SN74HC139		UNIT
				MIN	TYP	MAX	MIN	MAX	MIN	MAX	
t <sub>pd</sub>	A or B	Y	2 V		47	175	255		220		ns
			4.5 V		14	35	51		44		
			6 V		12	30	44		38		
t <sub>pd</sub>	$\bar{G}$	Y	2 V		39	175	255		220		ns
			4.5 V		11	35	51		44		
			6 V		10	30	44		38		
t <sub>t</sub>		Y	2 V		38	75	110		95		ns
			4.5 V		8	15	22		19		
			6 V		6	13	19		16		

C <sub>pd</sub>	Power dissipation capacitance per decoder	No load, T <sub>A</sub> = 25°C	25 pF typ
-----------------	---	--------------------------------	-----------

NOTE 1: Load circuit and voltage waveforms are shown in Section 1.