

7A / 4.6A / 3A, FAST RESPONSE, LOW DROPOUT POSITIVE LINEAR VOLTAGE REGULATORS

FEATURES

- Fixed and Adjustable Voltages 1.5V and 3.3V
- Optimized for Low Voltage Applications
- Output Current Capability 7A / 4.6A / 3A
- Guaranteed Dropout Voltage up to Full Rated Output
- Integrated Thermal and Short-Circuit Protection
- Compact 3-Pin Surface-Mount and Thru-Hole Standard Power Packages
- V_{REF} Accuracy
 - TCL1585A 1.0%
 - TCL158x 2.0%
- Load Regulation 0.05%

APPLICATIONS

- Pentium™, PentiumPro™ CPU Power Supplies
- PowerPC™ CPU Power Supplies
- PentiumPro™ System GTL+ Bus Terminators
- Low-Voltage, High Speed Microprocessors
- Post-Regulator for Switch-Mode Power Supplies

PIN CONFIGURATIONS

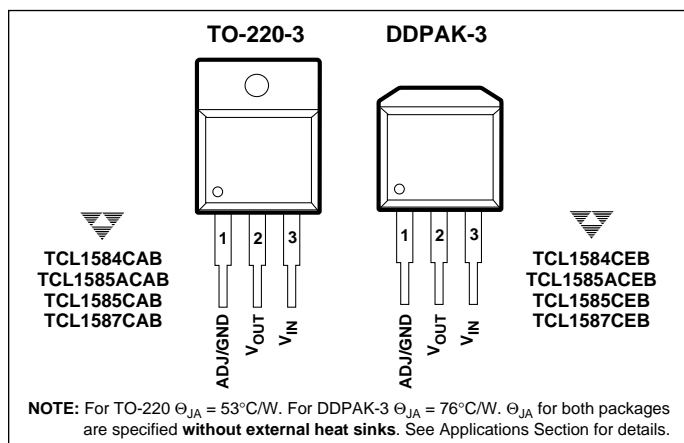

GENERAL DESCRIPTION

The TCL1584/1585/1587 are low dropout, positive linear voltage regulators. They have a maximum current output specification of 7A, 4.6A and 3A respectively. The TCL1585A has improved performance specifications over the standard versions. All three devices are supplied in fixed and adjustable output voltage versions.

Good transient load response combined with low dropout voltage makes these devices ideal for the latest low voltage microprocessor power supplies. Additionally, short-circuit, thermal and safe operating area (SOA), protection is provided internally to ensure reliable operation.

The TCL1587, TCL1585 and TCL1584 are available in a 3-pin TO-220 tabbed power package and in a 3-pin surface mount DDPak-3 package.

ORDERING INFORMATION

Part Number*	Package	Temp. Range
TCL1584CAB xx	TO-220-3	0°C to + 70°C
TCL1584CEB xx	DDPAK-3	0°C to + 70°C
TCL1585ACAB xx	TO-220-3	0°C to + 70°C
TCL1585ACEB xx	DDPAK-3	0°C to + 70°C
TCL1585CAB xx	TO-220-3	0°C to + 70°C
TCL1585CEB xx	DDPAK-3	0°C to + 70°C
TCL1587CAB xx	TO-220-3	0°C to + 70°C
TCL1587CEB xx	DDPAK-3	0°C to + 70°C

NOTE: **xx" denotes output voltage version. Ex: TCL1587CEB-3.3 is for the 3.3V TCL1587 in a DDPak-3 package. No numeric suffix indicates adjustable version. TCL1584/1585 are not available in a 1.5V version.

TYPICAL OPERATING CIRCUIT

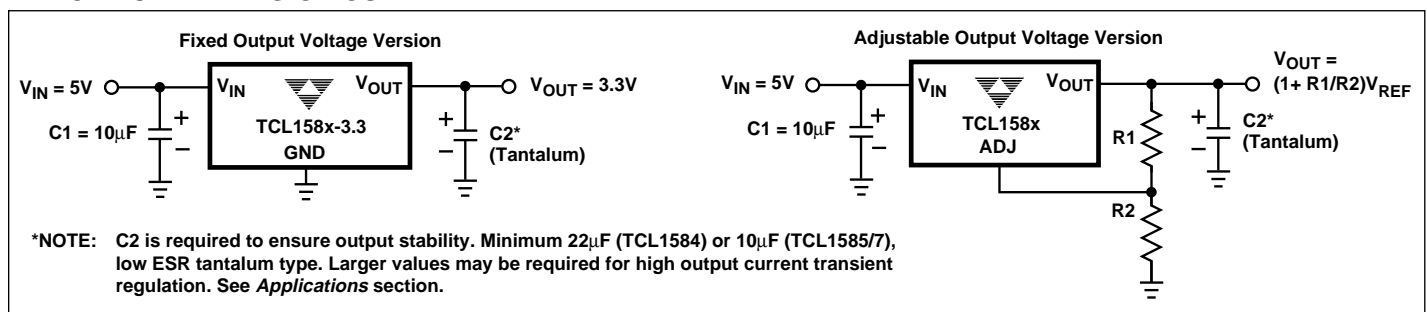

*All Trademarks and Trade Names are the property of their respective owners.

TCL1584
TCL1585
TCL1585A
TCL1587

ABSOLUTE MAXIMUM RATINGS*

Input Voltage (V_{IN} to GND) 7V
 Operating Junction Temperature Range
 Control Circuitry 0°C to +125°C
 Output Transistor 0°C to +150°C
 Power Dissipation See *Applications* Section
 Storage Temperature (unbiased) – 65°C to +150°C
 Lead Temperature (Soldering, 10 sec) +300°C

*This is a stress rating only, and functional operation of the device at these or any other conditions beyond those indicated in the operation section of the specifications is not implied. Exposure to absolute maximum ratings conditions for extended periods of time may affect device reliability.

ELECTRICAL CHARACTERISTICS: T_A = Operating Temperature Range, unless otherwise specified.

Parameter	Device	Test Conditions	TCL1585A			TCL158x			Unit
			Min	Typ	Max	Min	Typ	Max	
Reference Voltage	TCL1584	$1.5V \leq (V_{IN} - V_{OUT}) \leq 3V, 10mA \leq I_{OUT} \leq 7A$	—	—	—	1.225	1.250	1.275	V
	TCL1585	$1.5V \leq (V_{IN} - V_{OUT}) \leq 5.75V, 10mA \leq I_{OUT} \leq 4.6A, T_J \geq 25^\circ C$							
		$1.5V \leq (V_{IN} - V_{OUT}) \leq 5.75V, 10mA \leq I_{OUT} \leq 4A, T_J < 25^\circ C$							
	TCL1587	$1.5V \leq (V_{IN} - V_{OUT}) \leq 5.75V, 10mA \leq I_{OUT} \leq 3A$							
	TCL1585A	$1.5V \leq (V_{IN} - V_{OUT}) \leq 5.75V, 10mA \leq I_{OUT} \leq 5A, T_J = 25^\circ C$	1.238	1.250	1.262	—	—	—	V
	TCL1585A	$1.5V \leq (V_{IN} - V_{OUT}) \leq 5.75V, 10mA \leq I_{OUT} \leq 5A$	1.225	1.250	1.275	—	—	—	V
Output Voltage	TCL1587-1.5	$4.75V \leq V_{IN} \leq 7V, 0mA \leq I_{OUT} \leq 3A$	—	—	—	1.350	1.500	1.650	V
	TCL1584-3.3	$4.75V \leq V_{IN} \leq 6.3V, 0mA \leq I_{OUT} \leq 7A$	—	—	—	3.235	3.300	3.365	V
	TCL1585-3.3	$4.75V \leq V_{IN} \leq 7V, 0mA \leq I_{OUT} \leq 4.6A, T_J \geq 25^\circ C$							
		$4.75V \leq V_{IN} \leq 7V, 0mA \leq I_{OUT} \leq 4A, T_J < 25^\circ C$							
	TCL1587-3.3	$4.75V \leq V_{IN} \leq 7V, 0mA \leq I_{OUT} \leq 3A$							
Line Regulation (Notes 1, 2)	TCL1584/5/7	$2.75V \leq V_{IN} \leq 7V, I_{OUT} = 10mA$	—	0.005	0.2	—	0.005	0.2	%
	TCL1587-1.5	$4.75V \leq V_{IN} \leq 7V, I_{OUT} = 0mA$							
	TCL1584/5/7-3.3	$4.75V \leq V_{IN} \leq 7V, I_{OUT} = 0mA$							
Load Regulation (Notes 1, 2, 3)	TCL1584/5/7	$(V_{IN} - V_{OUT}) = 3V, T_J = 25^\circ C, 10mA \leq I_{OUT} \leq I_{FULL\ LOAD}$	—	0.005	0.3	—	0.005	0.3	%
	TCL1587-1.5	$V_{IN} = 5V, T_J = 25^\circ C, 0mA \leq I_{OUT} \leq I_{FULL\ LOAD}$							
	TCL1584/5/7-3.3	$V_{IN} = 5V, T_J = 25^\circ C, 0mA \leq I_{OUT} \leq I_{FULL\ LOAD}$							
Dropout Voltage	TCL1585A	$\Delta V_{REF} = 1\%, I_{OUT} = 5A$ $\Delta V_{REF} = 1\%, I_{OUT} = 3A$	—	—	1.400	—	—	—	V
			—	—	1.300				
	TCL1585/7	$\Delta V_{REF} = 1\%, I_{OUT} = 3A$	—	—	—	—	1.150	1.300	V
	TCL1587-1.5	$\Delta V_{OUT} = 1\%, I_{OUT} = 3A$							
	TCL1585/7-3.3	$\Delta V_{OUT} = 1\%, I_{OUT} = 3A$							
	TCL1585	$\Delta V_{REF} = 1\%, I_{OUT} = 4.6A, T_J \geq 25^\circ C$ $\Delta V_{REF} = 1\%, I_{OUT} = 4A, T_J < 25^\circ C$	—	—	—	—	1.200	1.400	V
	TCL1585-3.3	$\Delta V_{OUT} = 1\%, I_{OUT} = 4.6A, T_J \geq 25^\circ C$ $\Delta V_{OUT} = 1\%, I_{OUT} = 4A, T_J < 25^\circ C$							
	TCL1584	$\Delta V_{REF} = 1\%, I_{OUT} = 6A$	—	—	—	—	1.200	1.300	V
	TCL1584-3.3	$\Delta V_{OUT} = 1\%, I_{OUT} = 6A$							
	TCL1584	$\Delta V_{REF} = 1\%, I_{OUT} = 7A$	—	—	—	—	1.250	1.400	V
	TCL1584-3.3	$\Delta V_{OUT} = 1\%, I_{OUT} = 7A$							

7A / 4.6A / 3A, FAST RESPONSE, LOW DROPOUT POSITIVE LINEAR VOLTAGE REGULATORS

PRELIMINARY INFORMATION

TCL1584
TCL1585
TCL1585A
TCL1587

ELECTRICAL CHARACTERISTICS (Cont.): T_A = Operating Temperature Range, unless otherwise specified.

Parameter	Device	Test Conditions	TCL1585A			TCL158x			Unit
			Min	Typ	Max	Min	Typ	Max	
Current Limit (Note 3)	TCL1585A	$(V_{IN} - V_{OUT}) = 5.5V$	5.000	—	—	—	—	—	A
	TCL1584 TCL1584-3.3	$(V_{IN} - V_{OUT}) = 3V$ $(V_{IN} - V_{OUT}) = 3V$	—	—	—	7.100	8.250	—	A
	TCL1585 TCL1585-3.3	$(V_{IN} - V_{OUT}) = 5.5V$ $(V_{IN} - V_{OUT}) = 5.5V$ $T_J \geq 25^\circ C$ $T_J < 25^\circ C$	—	—	—	4.600	5.25	—	A
	TCL1587 TCL1587-1.5 TCL1587-3.3	$(V_{IN} - V_{OUT}) = 5.5V$ $(V_{IN} - V_{OUT}) = 5.5V$ $(V_{IN} - V_{OUT}) = 5.5V$	—	—	—	3.100	3.750	—	A
Temperature Coefficient	TBD	TBD							
ADJ Pin Current	TCL1584/5/7		—	55	120	—	55	120	μA
ADJ Pin Current Change (Note 3)	TCL1584 TCL1585/7	$1.5V \leq (V_{IN} - V_{OUT}) \leq 3V$, $10mA \leq I_{OUT} \leq I_{FULL\ LOAD}$ $1.5V \leq (V_{IN} - V_{OUT}) \leq 5.75V$, $10mA \leq I_{OUT} \leq I_{FULL\ LOAD}$	—	0.2	5	—	0.2	5	μA
Minimum Load Current	TCL1584/5/7	$1.5V \leq (V_{IN} - V_{OUT}) \leq 5.75V$	—	2	10	—	2	10	mA
Quiescent Current	TCL1587-1.5 TCL1584/5/7-3.3	$V_{IN} = 5V$ $V_{IN} = 5V$	—	8	13	—	8	13	mA
Ripple Rejection	TCL1584 TCL1584-3.3 TCL1585 TCL1585-3.3 TCL1587 TCL1587-1.5 TCL1587-3.3 TCL1585A	$f = 120Hz$, $C_{OUT} = 25\mu F$ Tant., $(V_{IN} - V_{OUT}) = 2.5V$, $I_{OUT} = 7A$ $f = 120Hz$, $C_{OUT} = 25\mu F$ Tant., $V_{IN} = 5.8V$, $I_{OUT} = 7A$ $f = 120Hz$, $C_{OUT} = 25\mu F$ Tant., $(V_{IN} - V_{OUT}) = 3V$, $I_{OUT} = 4.6A$, $T_J \geq 25^\circ C$ $f = 120Hz$, $C_{OUT} = 25\mu F$ Tant., $(V_{IN} - V_{OUT}) = 3V$, $I_{OUT} = 4A$, $T_J < 25^\circ C$ $f = 120Hz$, $C_{OUT} = 25\mu F$ Tant., $V_{IN} = 6.3V$, $I_{OUT} = 4.6A$, $T_J \geq 25^\circ C$ $f = 120Hz$, $C_{OUT} = 25\mu F$ Tant., $V_{IN} = 6.3V$, $I_{OUT} = 4A$, $T_J < 25^\circ C$ $f = 120Hz$, $C_{OUT} = 25\mu F$ Tant., $(V_{IN} - V_{OUT}) = 3V$, $I_{OUT} = 3A$ $f = 120Hz$, $C_{OUT} = 25\mu F$ Tant., $V_{IN} = 5.0V$, $I_{OUT} = 3A$ $f = 120Hz$, $C_{OUT} = 25\mu F$ Tant., $V_{IN} = 6.3V$, $I_{OUT} = 3A$ $f = 120Hz$, $C_{OUT} = 25\mu F$ Tant., $(V_{IN} - V_{OUT}) = 3.0V$, $I_{OUT} = 5A$	—	—	—	60	72	—	dB
Thermal Regulation	TCL1584/5/7 TCL1587-1.5 TCL1584/5/7-3.3	$T_A = 25^\circ C$, 30msec Pulse $T_A = 25^\circ C$, 30msec Pulse $T_A = 25^\circ C$, 30msec Pulse	—	0.004	0.02	—	0.004	0.02	%/W
Temperature Stability		$V_{IN} = 5V$, $I_{OUT} = 0.5A$	—	0.5	—	—	0.5	—	%

ELECTRICAL CHARACTERISTICS (Cont.): T_A = Operating Temperature Range, unless otherwise specified.

Parameter	Device	Test Conditions	TCL1585A			TCL158x			Unit
			Min	Typ	Max	Min	Typ	Max	
Long Term Stability		$T_A = 125^\circ\text{C}$, 1000Hrs.	—	0.03	1.0	—	0.03	1.0	%
RMS Output Noise (% of V_{OUT})		$T_A = 25^\circ\text{C}$, $10\text{Hz} \leq f \leq 10\text{kHz}$	—	0.003	—	—	0.003	—	%
Thermal Resistance (Junction to Case, θ_{JA})	TCL1584	"A" pkg. (TO-220): Control Circuitry/Power Transistor	—	—	0.65/2.7	—	—	0.65/2.7	$^\circ\text{C/W}$
	TCL1585	"A" pkg. (TO-220): Control Circuitry/Power Transistor	—	—	0.7/3.0	—	—	0.7/3.0	
	TCL1585	"E" pkg. (DDPAK-3): Control Circuitry/Power Transistor	—	—	0.7/3.0	—	—	0.7/3.0	
	TCL1587	"A" pkg. (TO-220): Control Circuitry/Power Transistor	—	—	0.7/3.0	—	—	0.7/3.0	
	TCL1587	"E" pkg. (DDPAK-3): Control Circuitry/Power Transistor	—	—	0.7/3.0	—	—	0.7/3.0	

- NOTE:**
1. See thermal regulation specifications for changes in output voltage due to heating effects. Load and line regulation are measured at a constant junction temperature by low duty cycle pulse testing.
 2. Load and line regulation are guaranteed up to the maximum power dissipation (25W for the TCL1584 in "A" pkg., 26.5W for the TCL1585 in "A" pkg., 18W for the TCL1587 in "A" pkg.). Power dissipation is determined by input/output voltage differential and output current. Guaranteed maximum output current/power will not be available over full input/output voltage range.
 3. $I_{FULL\ LOAD}$ is defined as the maximum value of output load current as a function of input-to-output voltage. $I_{FULL\ LOAD}$ is a nominal 7A for TCL1584, decreasing to approximately 3A as $V_{IN} - V_{OUT}$ increases from 3V to 7V. For the TCL1585/1585-3.3, $I_{FULL\ LOAD}$ is 4.6A for $T_J \geq 25^\circ\text{C}$ and 4A for $T_J < 25^\circ\text{C}$. For all other fixed voltage TCL1585's, $I_{FULL\ LOAD}$ is 4A. For the TCL1587, $I_{FULL\ LOAD}$ is 3A. The TCL1585 and 1587 have constant current limit with respect to V_{IN} and V_{OUT} .

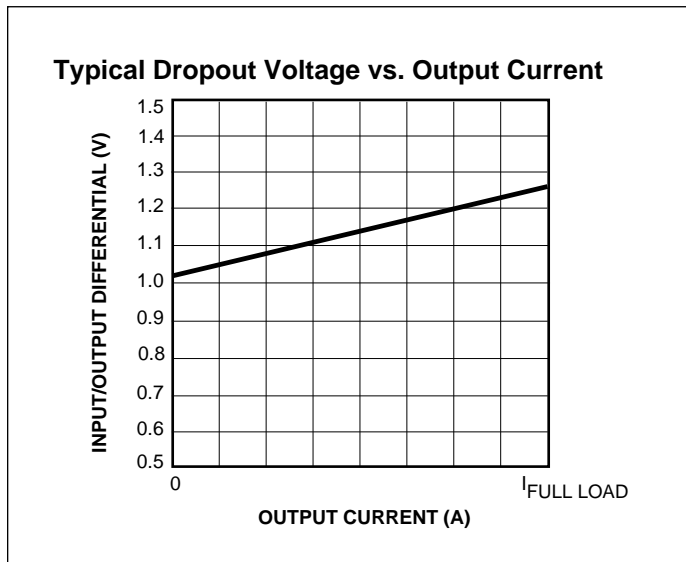

SIMPLIFIED SCHEMATIC

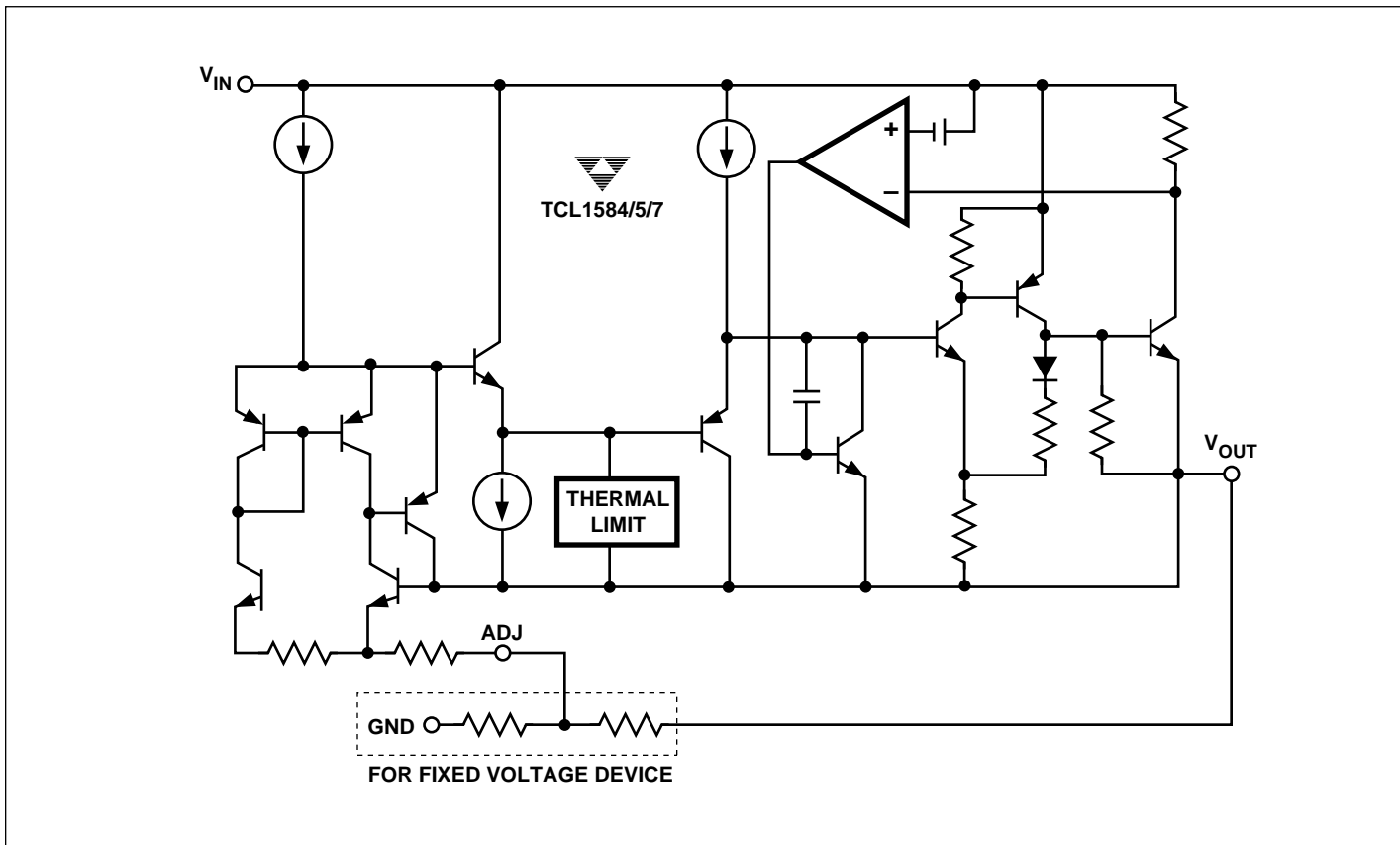

APPLICATIONS

General

The TCL158x family of devices combine high current output (up to 7A) with low dropout voltage and built-in fault protection in a traditional three-terminal LDO format. All three device types are available in fixed output voltage and adjustable output versions. Fault protection includes short-circuit current limit, over-temperature limit, and safe-operating-area (SOA) governing.

These devices are pin-compatible upgrades for the 1083/1084/1085 family of LDO's. However, the TCL158x family delivers lower dropout voltage, faster load transient response and improved internal frequency compensation. Maximum supply voltage rating is 7.0V.

Modern processors cycle load current from near zero to several amps in a time period measured in tens of nanoseconds. Load step response requirements are worsened by tighter output voltage tolerances. The TCL1584/85/85A/87 family of regulators meets these stringent requirements without an obnoxious amount of output capacitance, saving both board space and cost.

Stability and Transient Response

Like most low dropout voltage regulators, the TCL158x devices require the use of output capacitors to maintain stability. Normally a 22μF solid tantalum or a 100μF aluminum electrolytic unit will ensure stability over all operating conditions. Keep in mind that commercially available capacitors can have significant non-ideal effects such as capacitance value tolerance, temperature coefficient, ESR, ESL. The TCL158x devices are optimized for use with low ESR (<1Ω) capacitors.

On the adjustable voltage versions, bypassing the ADJ pin will improve ripple rejection and transient response. This is discussed in the *Ripple Rejection* section. This bypassing increases the required output capacitance value. The previously suggested minimum values (22μF and 100μF) take this into account. If no bypassing is used, lower values of output capacitance may be used.

Transient regulation is directly related to output capacitance value. For applications which require large load current step changes, it is recommended that large output capacitors (>100μF) be used. The value of the output capacitor can be increased without limit and will only improve transient regulation.

In a typical high-performance microprocessor application, the sudden transients can be so fast that the output decoupling network must handle the sudden current demand until the internal voltage regulator is able to respond. In this case the non-ideal effects of the output capacitor are critical in determining the regulator's response. Output voltage response to step load current change is illustrated in Figure 1. The capacitor's ESR and ESL cause immediate step changes in the output voltage. These are calculated as follows:

$$\Delta V_{ESR} = \Delta I \times ESR$$

$$DV_{ESL} = DI/Dt \times ESL$$

To reduce the initial voltage droop, one should select low ESR and ESL capacitors. It should also be noted that the ESR effect is multiplied by absolute change in load current while the ESL effect is multiplied by the *rate of change* in load current. After the initial voltage drop, the capacitor value dominates the rate of change in voltage. This rate is calculated as follows:

$$\Delta V = \Delta t \times \Delta I/C$$

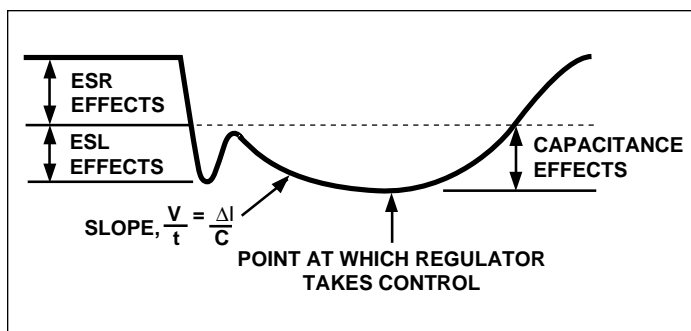

Figure 1. Transient Load Voltage Response

Typically high quality ceramic and tantalum capacitors must be used in combination to minimize ESR and maximize C. This decoupling network must also be placed close to the microprocessor to reduce ESL (parasitic board trace inductance). If possible, the capacitors should be placed *inside* the microprocessor socket cavity. Of course, robust power and ground planes will also improve performance by reducing parasitic voltage drops.

The TCL1584 has an adaptive current limiting scheme where to ensure SOA for the output transistor, the current limit is reduced for increasing input to output differential. This means that the TCL1584 exhibits a *negative resistance characteristic* under certain conditions. This is a common technique in LDO design to ensure SOA - especially LDO's with high maximum input voltage ratings. This negative resistance can interact with the external capacitance and

inductance and cause oscillations during current limit. This effect is highly dependent on system parameters and is difficult to predict. However this oscillation, if it occurs, will not damage the regulator and can be ignored if the system parameters will allow it. Typically, increasing the output capacitance helps reduce the oscillation. NOTE: The TCL1585 and TCL1584 have fixed current limit over the entire voltage range and are not susceptible to this phenomenon.

Protection Diodes

The TCL158x family of devices do not normally require any external current limiting circuitry such as protection diodes, frequently used with older LDO regulators. A diode is internally present between the output and input which is capable of handling short-duration surge currents of up to 100A. This capability typically ensures safe operation except for the case where output capacitance is exceedingly large (>1000μF) and the input is suddenly shorted to ground. This situation can produce excessive reverse current in the device - enough to cause damage. An external high current diode should be used as shown in Figure 2.

The ADJ pin does not normally need protection diodes either. It can handle ±7V without any performance degradation or device damage. Current at this pin is internally limited by a series resistor so the bypass capacitors do not present any danger. Of course, exceeding 7V differential between any two pins will cause catastrophic junction breakdowns and possible damage to the device.

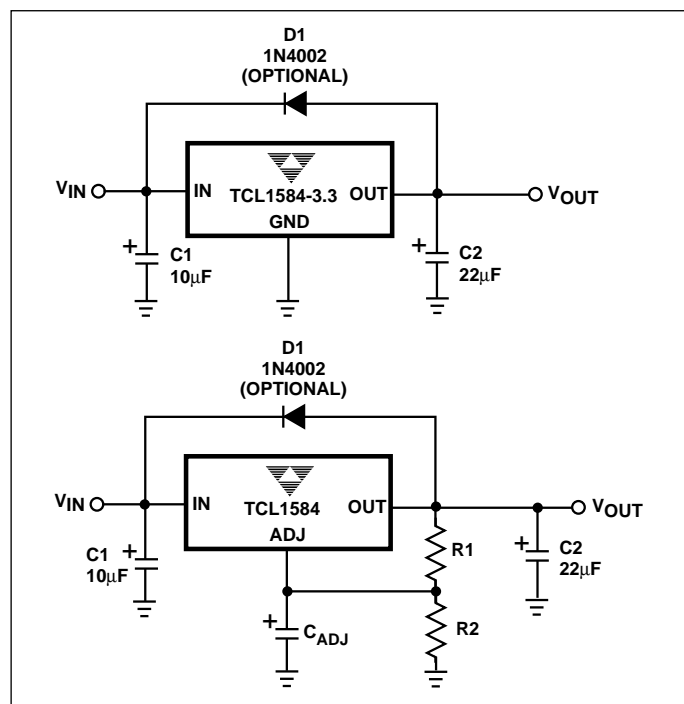

Figure 2. Protection Diodes and C_{ADJ}

Overload Recovery

The built-in Short Circuit and Safe-Operating-Area (SOA) protection function of the TCL158x family can cause secondary effects which must be considered for robust system design. The behavior of the regulator under heavy loads (short circuit) at start-up is such that the output voltage will remain low while sourcing maximum current until the load is removed or reduced. Normally, the output voltage will rise as the load is reduced and trace a line I-V relationship according to the SOA limit. If the load line intersects this output curve at two points the output voltage may not recover from the heavy load/short-circuit condition. This condition is illustrated in Figure 3. The current limit constraint does not allow any load point above it and the load line is defined absolutely by the I-V characteristics of the load (a resistor, in this case). Under these conditions it may be necessary to cycle the power supply off and then on again. This phenomenon is common for LDO's with fold-back current limiting schemes. NOTE: Overload recovery is *always* guaranteed on the TCL1585 and TCL1587 because of the constant current limit characteristic.

Ripple Rejection

A typical ripple rejection curve for the fixed output voltage devices is shown in Figure 3. It is possible to obtain improved performance in ripple rejection by using the adjustable output TC158x with a bypass capacitor (C_{ADJ}) shown in Figure 2. This capacitor should be chosen to have a value such that its impedance at the ripple frequency is less than R_1 (see Figure 2.). Usually this is on the order of 100Ω . Example: If $R_1 = 100\Omega$ and $f_{RIPPLE} = 120\text{Hz}$, the bypass capacitor should be chosen to be $22\mu\text{F}$ or greater. If these conditions are met the ripple rejection will be improved by a factor of $V_{OUT}/1.25$ when compared to the performance of the fixed output devices.

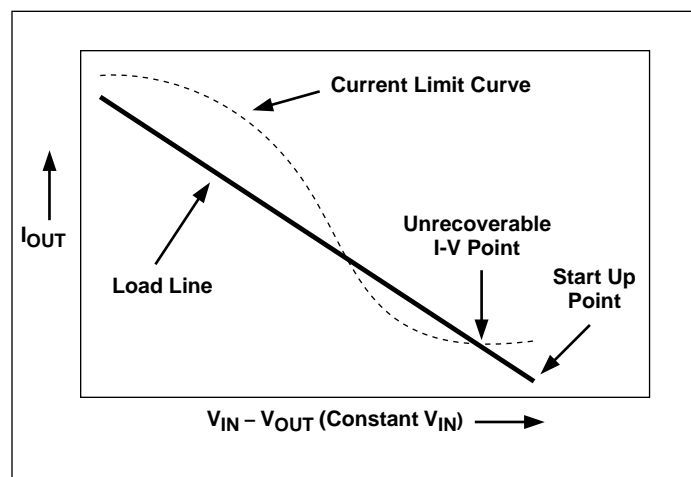

Figure 3. Overload Recovery

Output Voltage

The output voltage for the fixed output versions of the TCL158x is set internally and cannot be adjusted. For the adjustable output versions, the output voltage is set by two external resistors: R_1 and R_2 (see Figure 3). A 1.25V reference voltage is maintained between the OUTPUT pin and the ADJ pin. NOTE: the ADJ pin typically will source $55\mu\text{A}$. R_1 should be chosen to conduct at least the specified minimum load current of 10mA (i.e. at most 125Ω). Now R_2 will determine the total output voltage according to the equation below:

$$V_{OUT} = V_{REF}(1 + R_2/R_1) + R_2(I_{ADJ})$$

The contribution due to the I_{ADJ} term is relatively small as I_{ADJ} is only $55\mu\text{A}$ compared to 10mA for the total current in the adjust circuit.

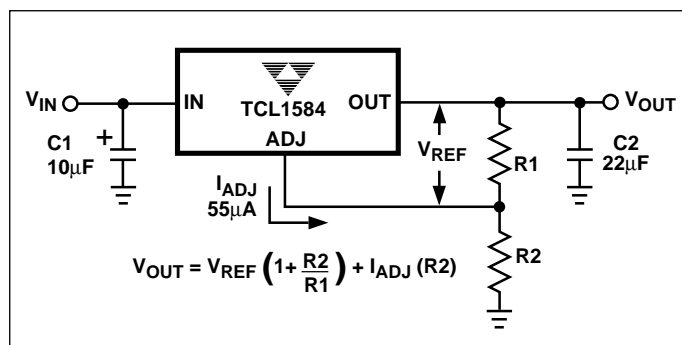

Figure 4. Adjustable Voltage Regulator

Load Regulation

Because the TCL158x family are three terminal devices, it is not possible to perform true Kelvin load voltage sensing. Therefore load regulation is limited somewhat by parasitic trace resistance. The load regulation specifications are measured *directly* at the TCL158x package. To minimize degradation in load regulation performance the following guidelines should be used.

For fixed voltage devices, the GND pin should be connected directly to the negative side of the load instead of to a common ground bus. This provides Kelvin sensing at the negative side while the positive side is still limited by R_P (See Figure 5).

For adjustable output devices, the bottom of R_2 connects to the negative side of the load. For the positive side, best regulation is obtained when the top of R_1 is connected directly to the TCL158x and not to the load (See Figure 6). If R_1 connects to the load the effective resistance between the output and the load is:

$$R_P \times (1 + R_2/R_1)$$

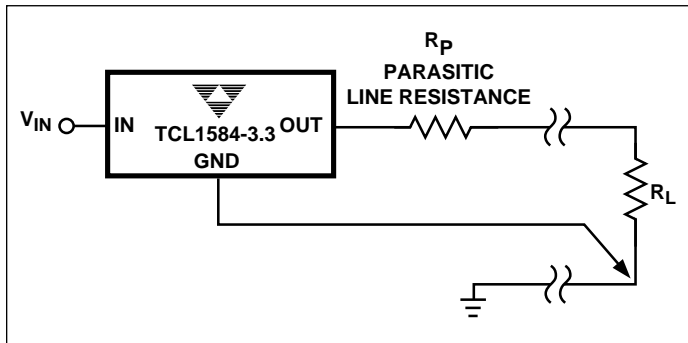

Figure 5. Connection for Best Load Regulation

In both cases, because the effect of parasitic trace resistance (R_p) cannot be completely eliminated, it is important to keep the positive output lead as short as possible. Otherwise, at high output currents, the load regulation will degrade appreciably. Example:

$$R_p = 5\text{m}\Omega$$

$$I_{OUT} = 3\text{A}$$

$$V_{DROP} = (0.005) \times (3) = 15\text{mV}$$

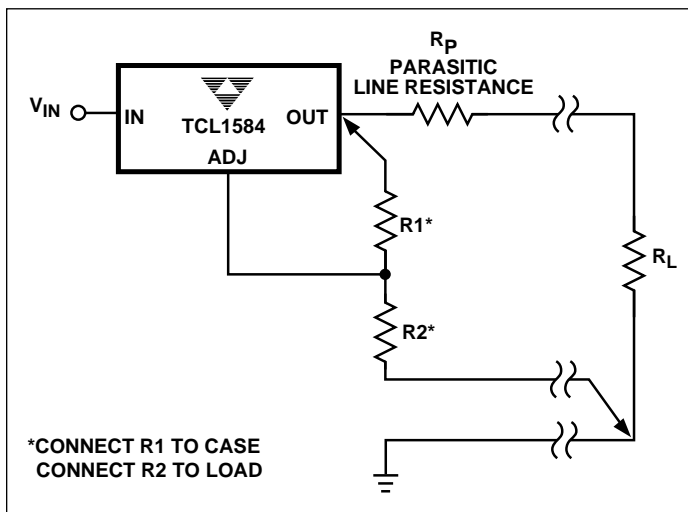

Figure 6. Connection for Best Load Regulation

Thermal Considerations

The TCL158x family includes built-in thermal overload protection. However, maximum operating junction temperature *must not be exceeded* for any condition. Since these devices are capable of dissipating up to 25W or more under some conditions, careful thermal design is required for reliable, continuous operation. In most cases, external heat sinking will be required.

When generating the overall thermal design, it is important to consider all sources of thermal resistance between the silicon die and ambient - junction-to-case (Θ_{JC}), case-to-

heat sink (Θ_{CH}), heat sink-to-ambient (Θ_{HA}). NOTE: there are two separate Θ_{JC} specifications for the power transistor and the control circuitry. Both junction temperatures must be calculated and kept under each respective maximum limit to ensure proper operation. This Θ_{JC} is for the physical path between the die and the bottom metal portion of the case (both TO-220 and DDPK-3. Heat flow will be greatest through this path. It is important that good thermal coupling is made between the case and heat sink. If electrical isolation from the heat sink is not required, it is recommended that thermally conductive compound be used. Otherwise, use a thermally conductive dielectric spacer. The following is a thermal design example:

Using a TCL1585-3.3 in a TO-220 package:

Assumptions:

$$T_A = +70^\circ\text{C}$$

$$V_{IN} = 5.25\text{V} (5\text{V} + 5\%)$$

$$V_{OUT} = 3.30\text{V}$$

$$I_{OUT} = 4.6\text{A}$$

$$\Theta_{HA} = 3.5^\circ\text{C/W} (\text{heat sink-to-ambient})$$

$$\Theta_{CH} = 1.5^\circ\text{C/W} (\text{case-to-heat sink})$$

$$\Theta_{JC} = 3^\circ\text{C/W} (\text{power transistor})$$

$$\Theta_{JC} = 0.7^\circ\text{C/W} (\text{control circuitry})$$

Power dissipation:

$$P_D = (V_{IN} - V_{OUT})(I_{OUT}) = (5.25 - 3.3)(4.6) = 8.97\text{W}$$

Junction Temperatures:

$$T_J = T_A + P_D(\Theta_{HA} + \Theta_{CH} + \Theta_{JC})$$

Control Circuitry:

$$T_J = 70 + 8.97(3.5 + 1.5 + 0.7) = 121.1^\circ\text{C}$$

Power Transistor:

$$T_J = 70 + 8.97(3.5 + 1.5 + 3) = 141.8^\circ\text{C}$$

These values for T_J fall within the maximum allowed junction temperature for each die section indicating adequate heat sinking with some margin.

NOTE: Without heat sinking, the thermal resistance for the TO-220 and DDPK-3 packages are 53°C/W and 76°C/W respectively.

TYPICAL APPLICATIONS

Typical Intel™ 486x4 Microprocessor Application

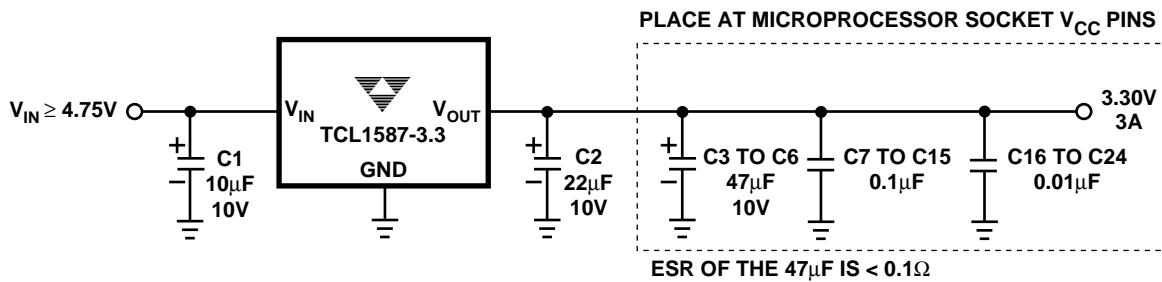

Intel™ 90MHz Pentium™ Power Supply

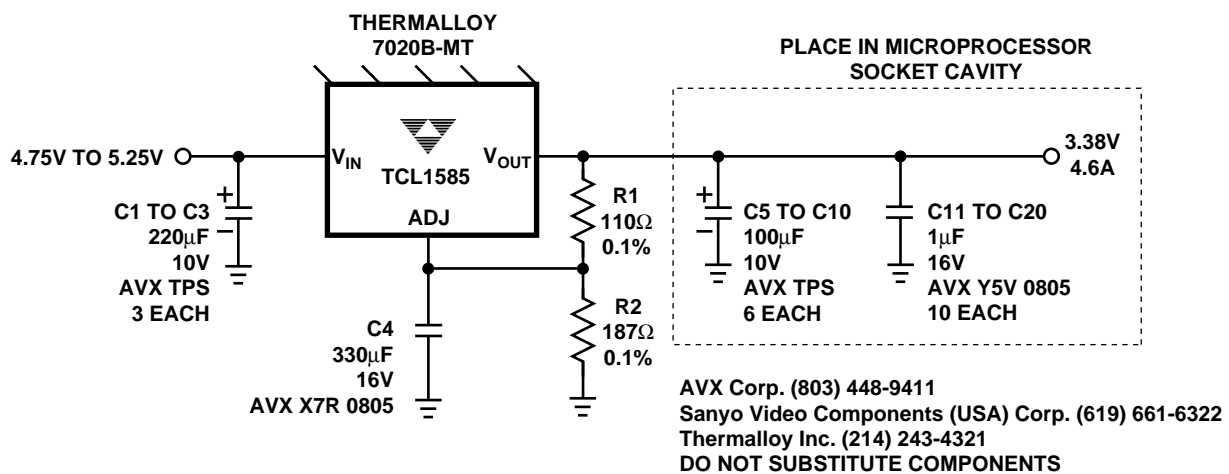

Transient Response for 3.8A Load Current Step*

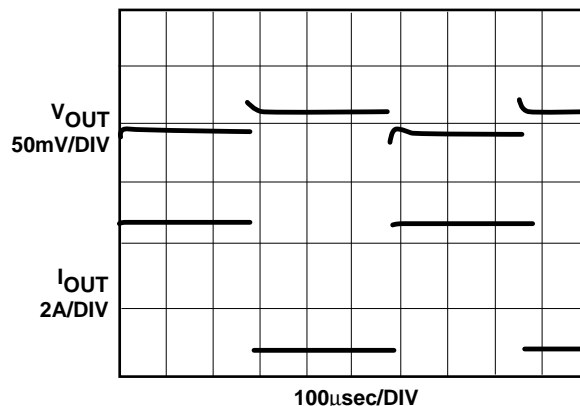

*TRANSIENT RESPONSE MEASURED WITH AN INTEL POWER VALIDATOR™. V_{OUT} IS MEASURED AT THE POWER VALIDATOR.

All Trademarks and Trade Names are the property of their respective owners.

TYPICAL APPLICATIONS (Cont.)

Typical Intel™ Pentium™ Pro GTL+ Bus Terminator Application Using TCL1587-1.5

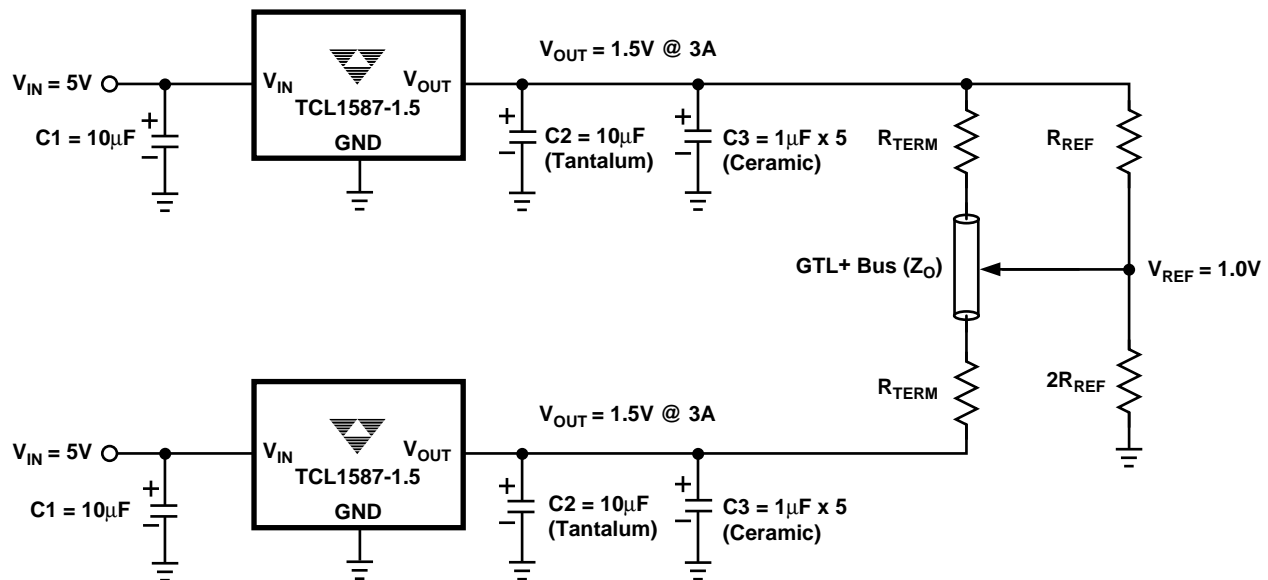

- NOTES:**
1. It is recommended that the GTL+ bus be terminated at each end by a separate regulator to avoid power distribution losses.
 2. The GTL+ bus transmission line symbol will consist of all the components (chip set IC's) on the GTL+ bus.
 3. R_{REF} and $2R_{REF}$ should be chosen such that V_{REF} loading does not appreciably degrade V_{REF} regulation. Values <100 ohms should suffice for most applications.
 4. R_{TERM} will be determined by individual bus physical/electrical parameters. See CPU manufacturer documentation for application information.

*All Trademarks and Trade Names are the property of their respective owners.

7A / 4.6A / 3A, FAST RESPONSE, LOW DROPOUT POSITIVE LINEAR VOLTAGE REGULATORS

PRELIMINARY INFORMATION

TCL1584
TCL1585
TCL1585A
TCL1587

TYPICAL CHARACTERISTICS

TCL1584 Dropout Voltage vs. Output Current

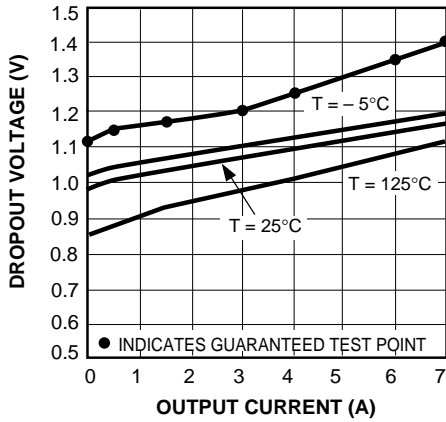

TCL1584 Short Circuit Current vs. Input/Output Differential

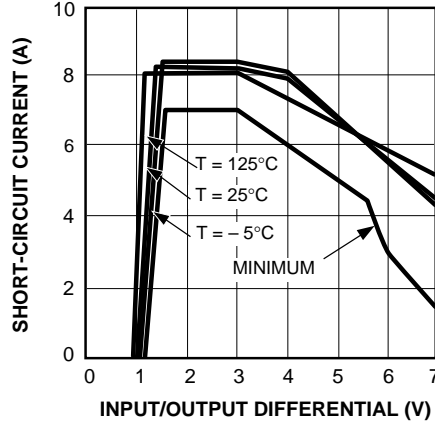

TCL1584 Load Regulation vs. Temperature

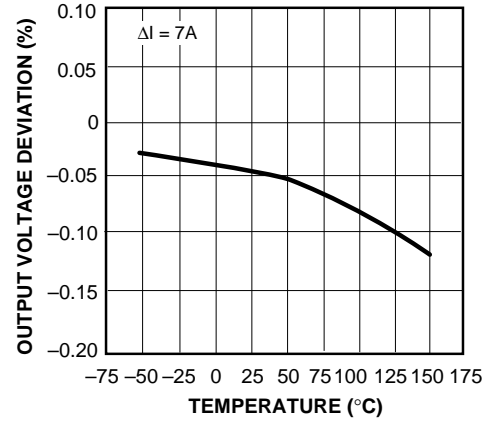

TCL1585 Dropout Voltage vs. Output Current

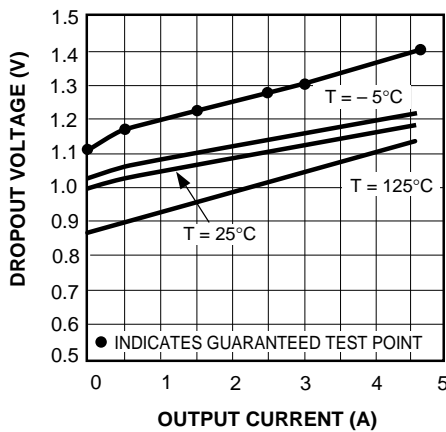

TCL1585 Short-Circuit Current vs. Temperature

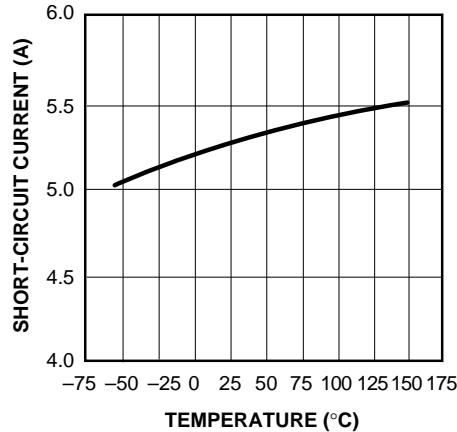

TCL1585 Load Regulation vs. Temperature

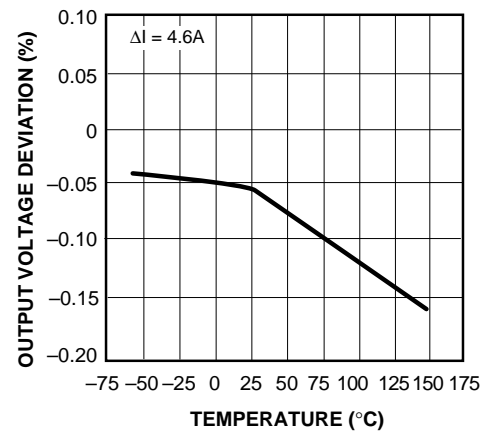

TCL1587 Dropout Voltage vs. Output Current

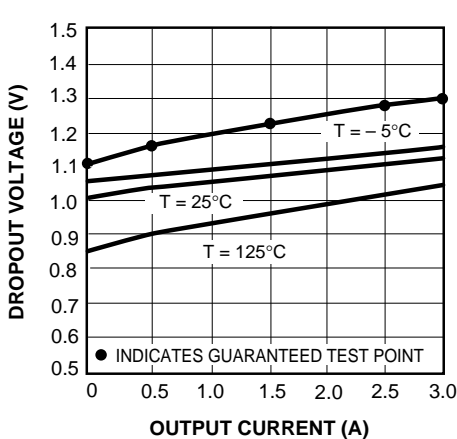

TCL1587 Short-Circuit Current vs. Temperature

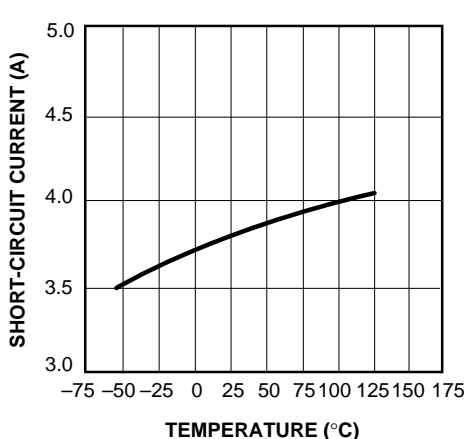

TCL1587 Load Regulation vs. Temperature

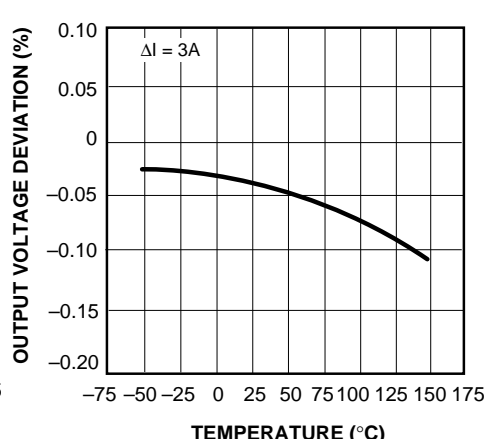

TYPICAL CHARACTERISTICS (Cont.)

TCL1584/5/7 Reference Voltage vs. Temperature

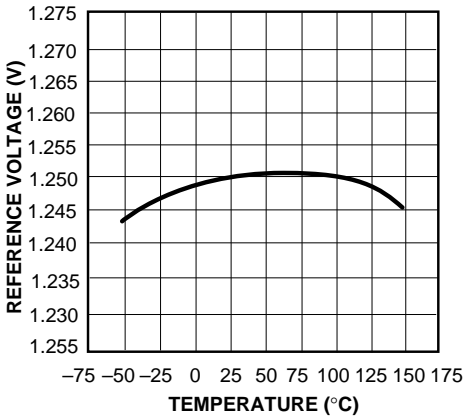

Output Voltage vs Temperature Using Adjustable TCL1584/5/7

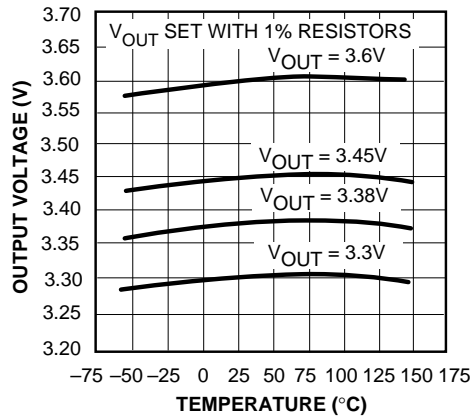

TCL1584/5/7-3.3 Output Voltage vs. Temperature

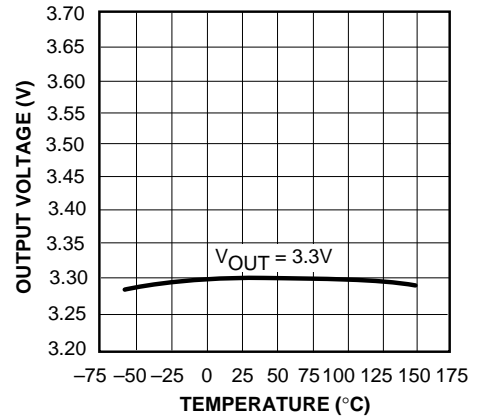

TCL1584/5/7 Minimum Load Current vs. Temperature

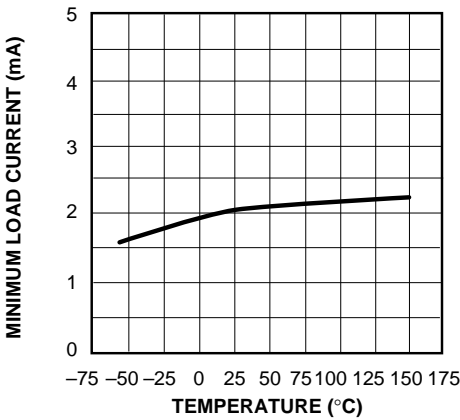

TCL1584/5/7 Adjust Pin Current vs. Temperature

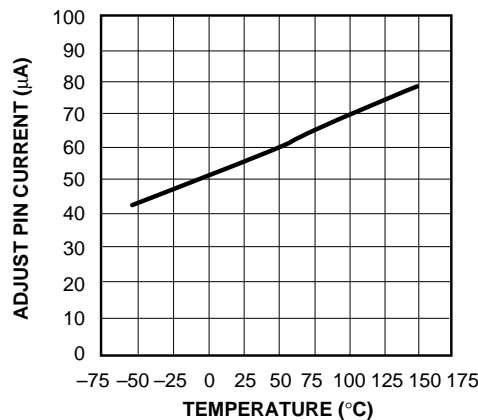

TCL1584/5/7-3.xx Quiescent Current vs. Temperature

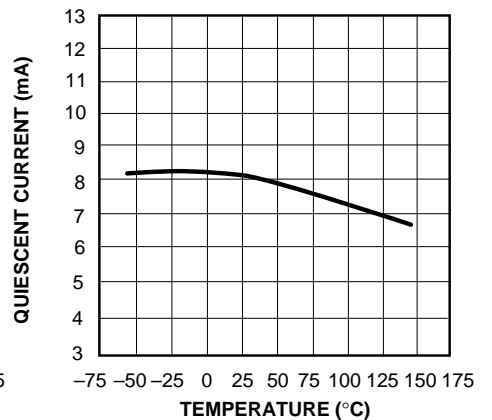

TCL1584/5/7 Ripple Rejection vs. Frequency

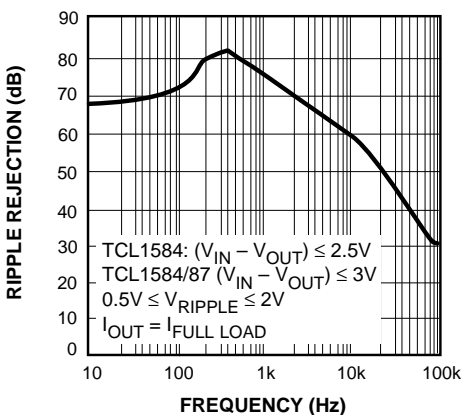

TCL1585/7 Maximum Power Dissipation*

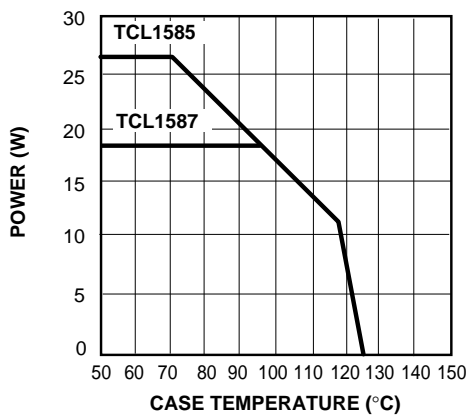

TCL1584 Maximum Power Dissipation*

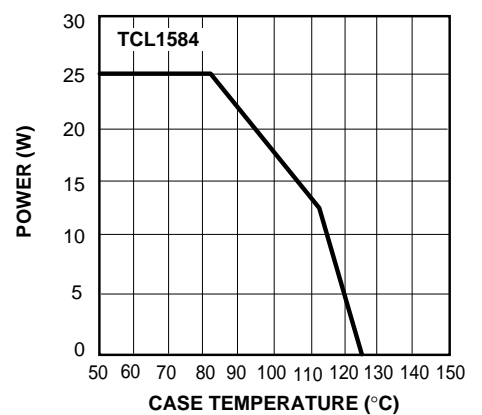

*AS LIMITED BY MAXIMUM JUNCTION TEMPERATURE

*AS LIMITED BY MAXIMUM JUNCTION TEMPERATURE

**7A / 4.6A / 3A, FAST RESPONSE,
LOW DROPOUT POSITIVE LINEAR
VOLTAGE REGULATORS**

PRELIMINARY INFORMATION

**TCL1584
TCL1585
TCL1585A
TCL1587**

PACKAGE DIMENSIONS

DDPAK-3

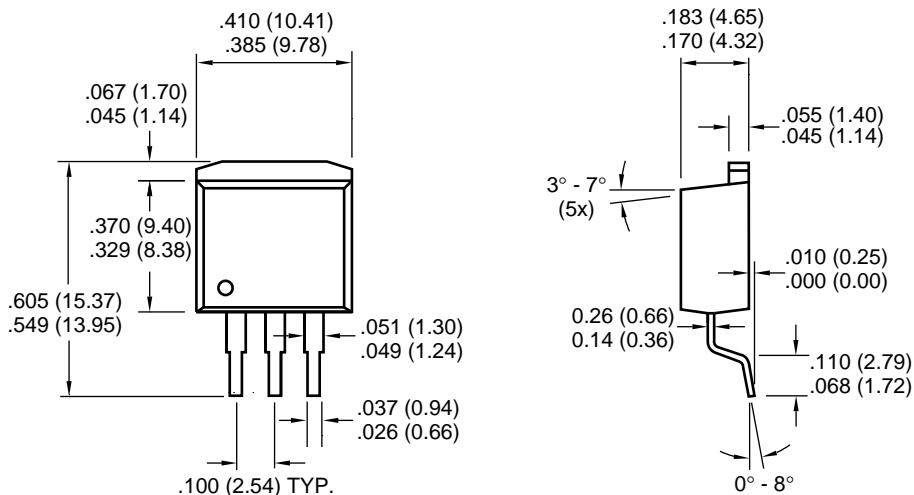

TO-220-3

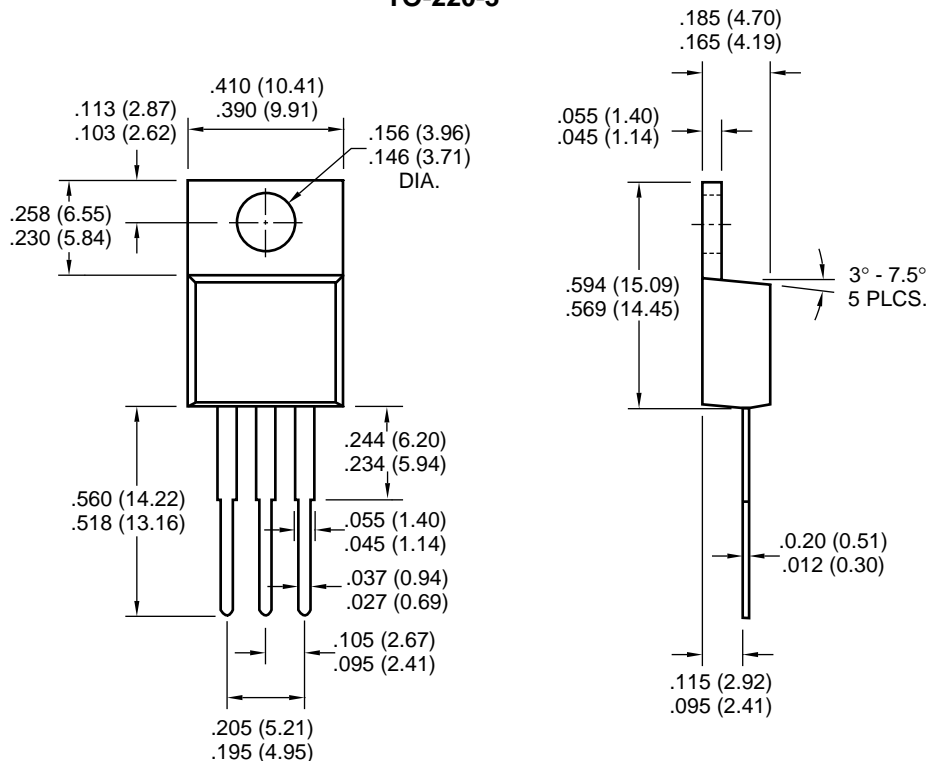

Dimensions: inches (mm)

Sales Offices

TelCom Semiconductor
1300 Terra Bella Avenue
P.O. Box 7267
Mountain View, CA 94039-7267
TEL: 415-968-9241
FAX: 415-967-1590
E-Mail: liter@c2smtp.telcom-semi.com

TelCom Semiconductor
Austin Product Center
9101 Burnet Rd. Suite 214
Austin, TX 78758
TEL: 512-873-7100
FAX: 512-873-8236

TelCom Semiconductor H.K. Ltd.
10 Sam Chuk Street, Ground Floor
San Po Kong, Kowloon
Hong Kong
TEL: 852-2324-0122
FAX: 852-2354-9957