

LMP8272

*LMP8272 High Common Mode, Gain of 14, Precision Voltage Difference
Amplifier*



Literature Number: SNOSAP7E

High Common Mode, Gain of 14, Precision Voltage Difference Amplifier

General Description

The LMP8272 is a fixed gain differential amplifier with a -2V to 16V input common mode voltage range and a supply voltage range of 4.75V to 5.5V. The LMP8272 is part of the LMP® precision amplifier family which will detect, amplify, and filter small differential signals in the presence of high common mode voltages. The gain is fixed at 14 and is adequate to drive an ADC to full scale in most cases. This fixed gain is achieved in two separate stages, a pre-amplifier with gain of +7 and a second stage amplifier with a gain of +2. The internal signal path between these two stages is brought out on two pins that provide a connection for a filter network.

The LMP8272 will function over an extended common mode input voltage range making the device suitable for applications with load dump events such as automotive systems.

Features

Typical Values, $T_A = 25^\circ\text{C}$

- Input offset voltage ±1 mV max
- TCV_{OS} ±15 $\mu\text{V}/^\circ\text{C}$ max
- CMRR 80 dB min
- Output voltage swing Rail-to-rail
- Bandwidth 80 kHz
- Operating temperature range (ambient) -40°C to 125°C
- Supply voltage 4.75V to 5.5V
- Supply current 1 mA

Applications

- Fuel injection control
- High and low side driver configuration current sensing
- Power management systems

Typical Application

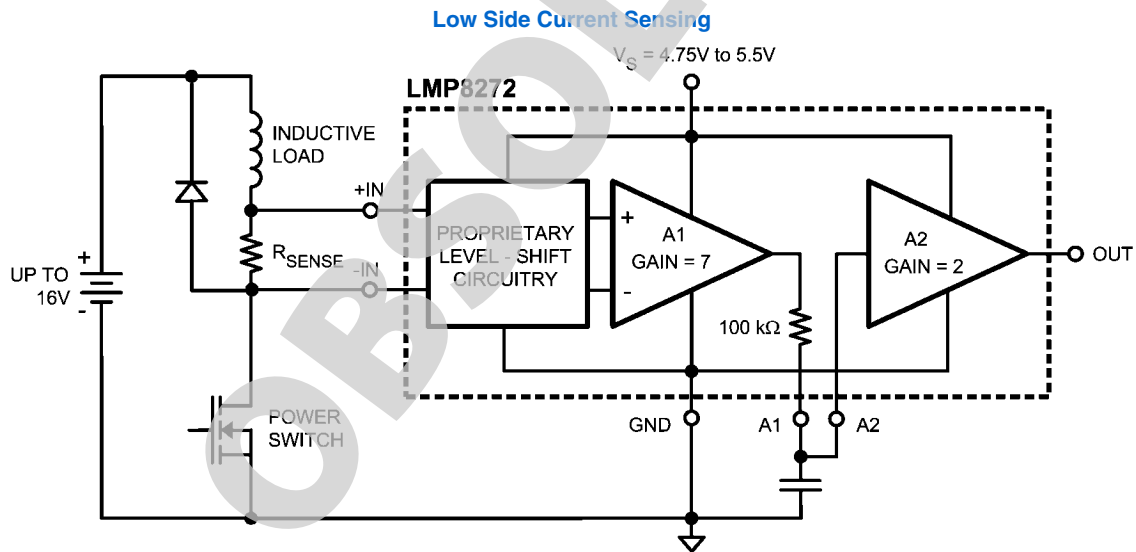

20150701

Absolute Maximum Ratings (Note 1)

If Military/Aerospace specified devices are required, please contact the National Semiconductor Sales Office/Distributors for availability and specifications.

ESD Tolerance (Note 2)

Human Body Model

For input pins only

±4000V

For All other pins

±2000V

Machine Model

200V

Supply Voltage (V_S - GND)

5.75V

Common Mode Voltage on +IN and -IN

Transient (400 ms)

-7V to 45V

Storage Temperature Range

-65°C to +150°C

Junction Temperature (Note 3)

+150°C max

Soldering Information

Infrared or Convection (20 sec)

235°C

Wave Soldering Lead Temp. (10 sec)

260°C

Operating Ratings (Note 1)

Temperature Range

Packaged Devices (Note 3)

-40°C to +125°C

Supply Voltage (V_S - GND)

4.75V to 5.5V

Package Thermal Resistance (θ_{JA} (Note 3))

8-Pin SOIC

190°C/W

5V Electrical Characteristics (Note 4)

Unless otherwise specified, all limits are guaranteed for $T_A = 25^\circ\text{C}$, $V_S = 5\text{V}$, $\text{GND} = 0$, $-2\text{V} \leq V_{CM} \leq 16\text{V}$, $R_L = \text{Open}$. **Boldface** limits apply at the temperature extremes.

Symbol	Parameter	Conditions		Min	Typ (Note 5)	Max	Units
V_{OS}	Input Offset Voltage	$V_{CM} = V_S/2$ (Note 6)			±0.25	±1.0	mV
$TC V_{OS}$	Input Offset Voltage Drift	$V_{CM} = V_S/2$	$25^\circ\text{C} \leq T_A \leq 125^\circ\text{C}$		±6	±15	$\mu\text{V}/^\circ\text{C}$
			$-40^\circ\text{C} \leq T_A \leq 25^\circ\text{C}$		±6	±20	
$A2 I_B$	Input Bias Current of A2	(Note 7)				±20	nA
I_S	Supply Current				1.0	1.2 1.4	mA
R_{CM}	Input Impedance Common Mode			160	200	240	$\text{k}\Omega$
R_{DM}	Input Impedance Differential Mode			320	400	480	$\text{k}\Omega$
CMVR	Input Common-Mode Voltage Range	Continuous		-2		+16	V
DC CMRR	DC Common Mode Rejection Ratio	$0^\circ\text{C} \leq T_A \leq 125^\circ\text{C}$	$-2\text{V} \leq V_{CM} \leq 16\text{V}$	80	97		dB
		$-40^\circ\text{C} \leq T_A \leq 0^\circ\text{C}$	$-2\text{V} \leq V_{CM} \leq 16\text{V}$	77			
AC CMRR	AC Common Mode Rejection Ratio (Note 8)	$-2\text{V} \leq V_{CM} \leq 16\text{V}$	$f = 1\text{ kHz}$	80	95		dB
			$f = 10\text{ kHz}$		78		
PSRR	Power Supply Rejection Ratio	$4.75\text{V} \leq V_S \leq 5.5\text{V}$		70	80		dB
R_{F-INT}	Filter Resistor			97	100	103	$\text{k}\Omega$
TCR_{F-INT}	Filter Resistor Drift				20		$\text{ppm}/^\circ\text{C}$
A_V	Total Gain			13.86	14	14.14	V/V
	Gain Drift				±2	±25	$\text{ppm}/^\circ\text{C}$
A_{V1}	A1 Gain			6.93	7	7.07	V/V
A_{V2}	A2 Gain			1.98	2	2.02	V/V
$A1 V_{OUT}$	A1 Output Voltage Swing	VOL			0.004	0.01	V
		VOH		4.80	4.95		
$A2 V_{OUT}$	A2 Output Voltage Swing (Note 9, Note 10)	$R_L = 100\text{ k}\Omega$ on Output	VOL		0.007	0.02	V
			VOH	4.80	4.99		
		$R_L = 10\text{ k}\Omega$ on Output	VOL		0.003		V
			VOH		4.95		
SR	Slew Rate (Note 11)				0.7		$\text{V}/\mu\text{s}$
BW	Bandwidth				80		kHz
Noise	0.1 Hz to 10 Hz				3.82		μV_{PP}
	Spectral Density	$f = 1\text{ kHz}$			486		$\text{nV}/\sqrt{\text{Hz}}$

Note 1: Absolute Maximum Ratings indicate limits beyond which damage to the device may occur. Operating Ratings indicate conditions for which the device is intended to be functional, but specific performance is not guaranteed. For guaranteed specifications and the test conditions, see the Electrical Characteristics Tables.

Note 2: Human Body Model is 1.5 k Ω in series with 100 pF. Machine Model is 0 Ω in series with 200 pF.

Note 3: The maximum power dissipation is a function of $T_{J(MAX)}$, θ_{JA} , and T_A . The maximum allowable power dissipation at any ambient temperature is $P_D = (T_{J(MAX)} - T_A) / \theta_{JA}$. All numbers apply for packages soldered directly onto a PC board.

Note 4: Electrical table values apply only for factory testing conditions at the temperature indicated. Factory testing conditions result in very limited self-heating of the device.

Note 5: Typical values represent the parametric norm at the time of characterization.

Note 6: The V_{OS} maximum limit indicated does not include effect of lifetime drift, see Application Note.

Note 7: Positive current corresponds to current flowing into the device.

Note 8: AC Common Mode Signal is a 16 V_{PP} sine-wave (0V to 16V) at the given frequency.

Note 9: For VOL, R_L is connected to V_S and for VOH, R_L is connected to GND.

Note 10: For this test input is driven from A1 stage.

Note 11: Slew rate is the average of the rising and falling slew rates.

Connection Diagram

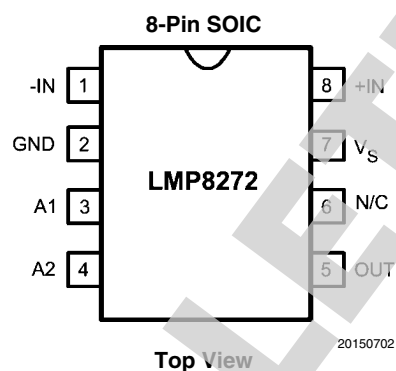

Ordering Information

Package	Part Number	Package Marking	Transport Media	NSC Drawing
SOIC-8	LMP8272MA	LMP8272MA	95 Units/Rail	M08A
	LMP8271MAX		2.5k Units Tape and Reel	

Typical Performance Characteristics

Unless otherwise specified: $T_A = 25^\circ\text{C}$, $V_S = 5\text{V}$, $V_{CM} = V_S/2$

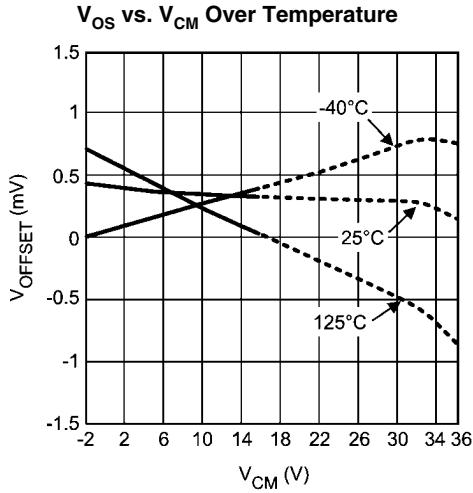

20150715

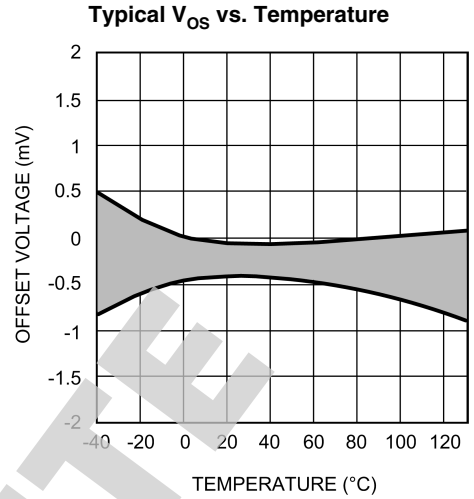

20150721

Input Bias Current Over Temperature (A1 Inputs)

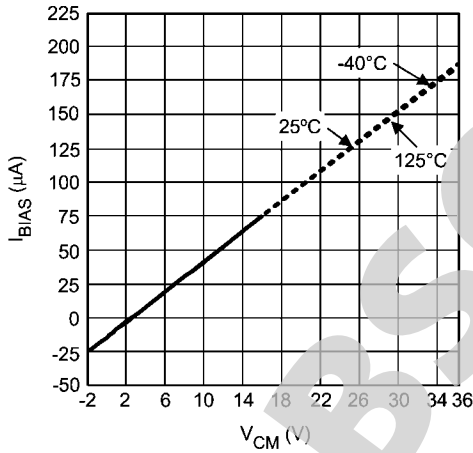

20150719

Input Bias Current Over Temperature (A2 Inputs)

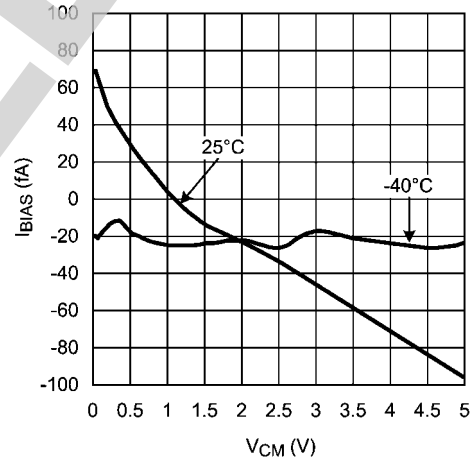

20150718

Input Bias Current Over Temperature (A2 Inputs)

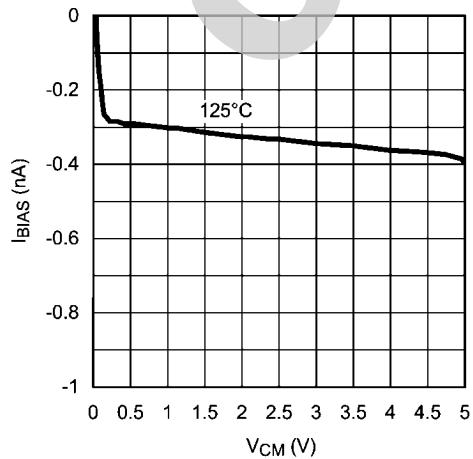

20150720

Input Referred Voltage Noise vs. Frequency

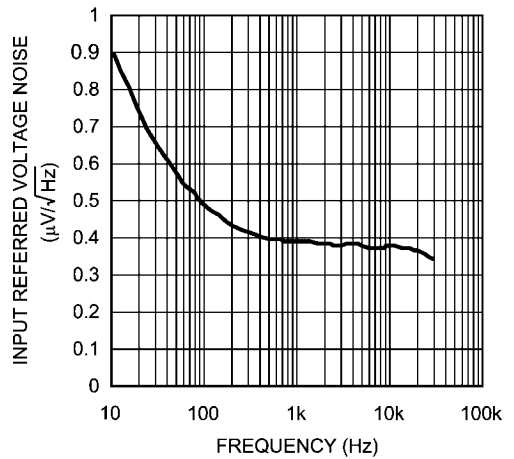

20150706

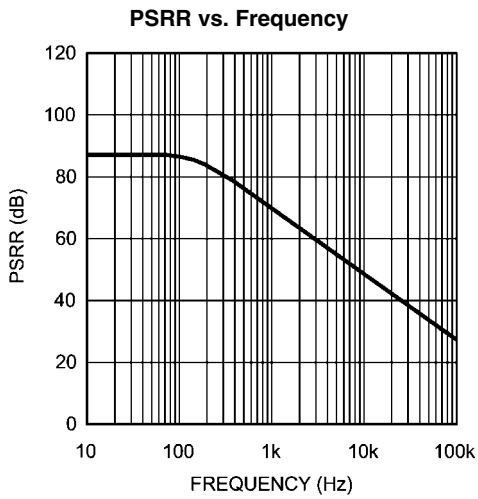

20150723

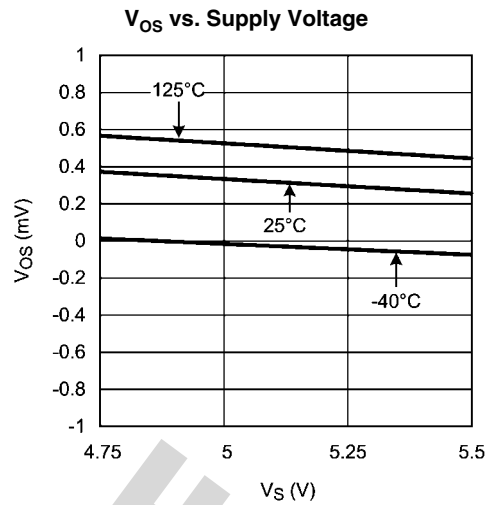

20150722

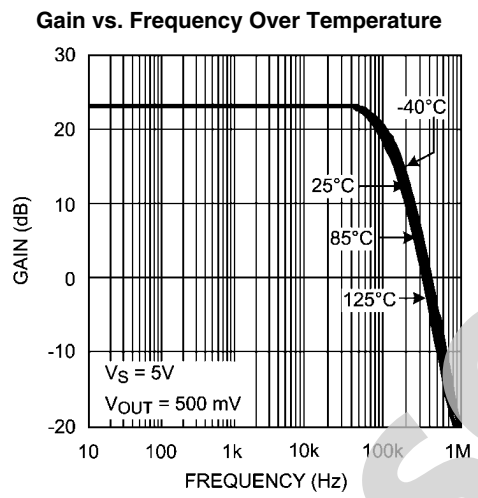

20150712

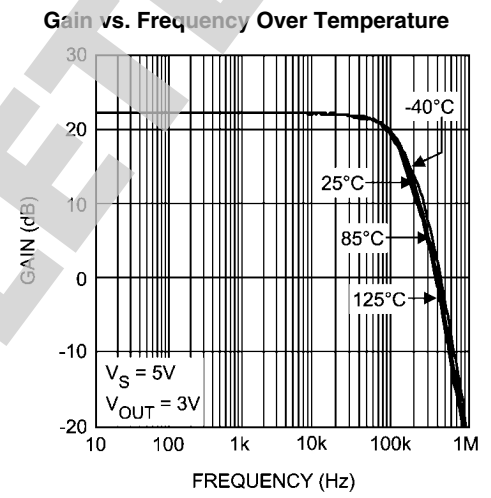

20150711

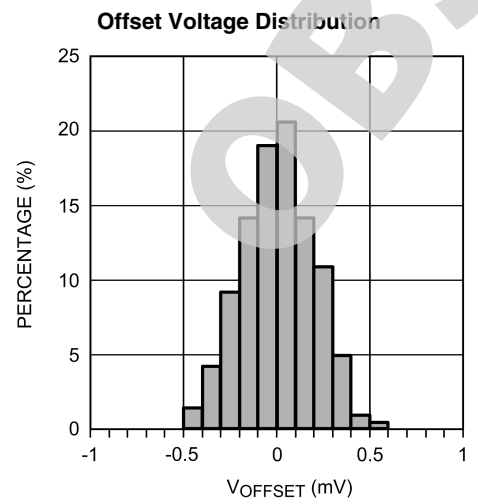

20150716

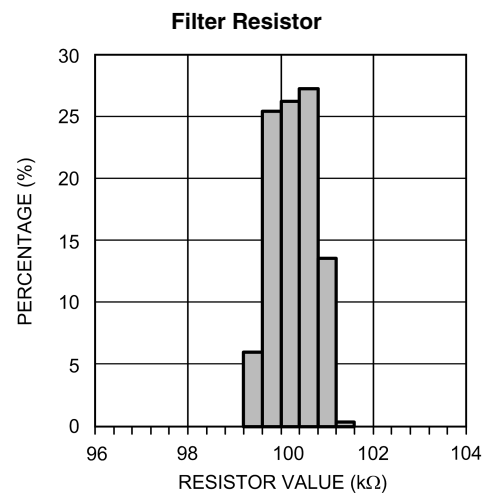

20150717

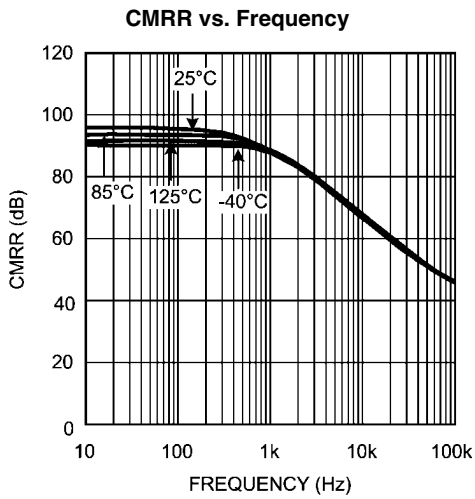

20150714

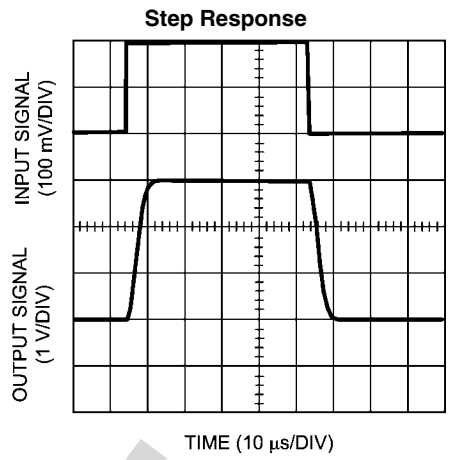

20150708

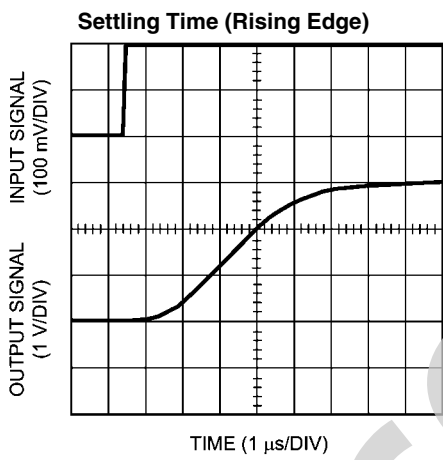

20150710

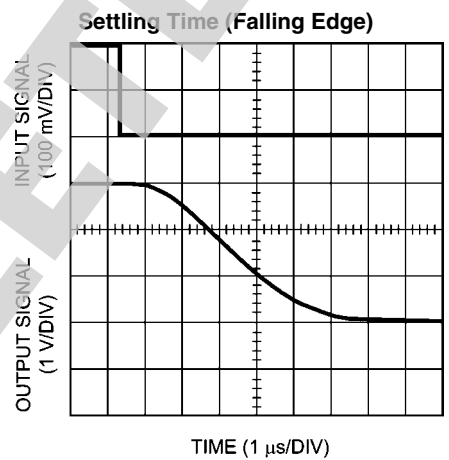

20150709

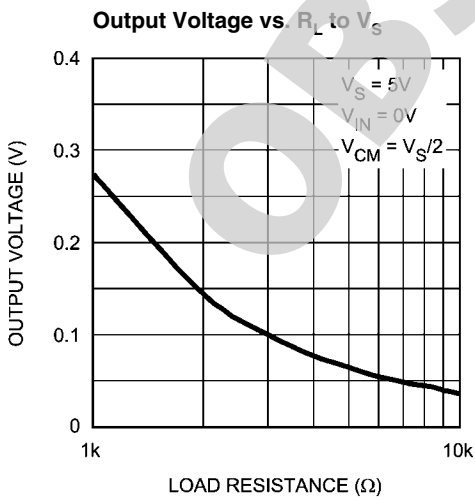

20150713

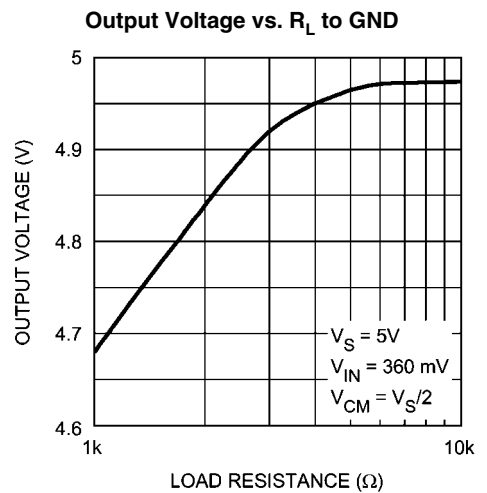

20150707

Application Note

LMP8272

The LMP8272 is a single supply amplifier with a fixed gain of 14 and a common mode voltage range of $-2V$ to $16V$. The fixed gain is achieved in two separate stages, a preamplifier with gain of $+7$ and a second stage amplifier with gain of $+2$. A block diagram of the LMP8272 is shown in *Figure 1*.

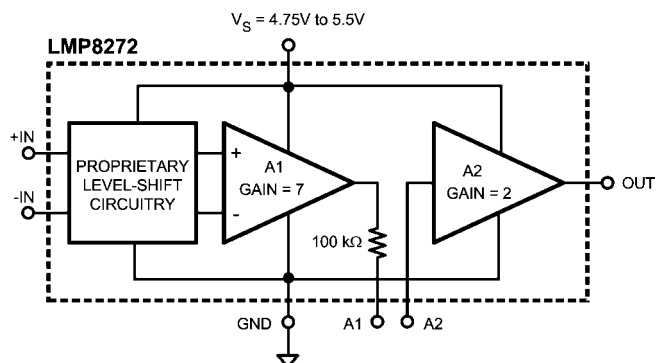

20150703

FIGURE 1. LMP8272

The overall offset of the LMP8272 is minimized by trimming amplifier A1. This is done so that the output referred offset of A1 cancels the input referred offset of A2 or $7V_{OS1} = -V_{OS2}$. Because of this offset voltage relationship, the offset of each individual amplifier stage may be more than the limit specified for the overall system in the datasheet tables. Care must be given when pin 3 and 4, A1 and A2, are connected to each other. If the signal going from A1 to A2 is amplified or attenuated (by use of amplifiers and resistors), the overall LMP8272 offset will be affected as a result. Filtering the signal between A1 and A2 or simply connecting the two pins will not change the offset of the LMP8272.

Referencing the input referred offset voltages of each stage, the following relationship holds:

$$\frac{(7V_{OS1}) + (V_{OS2})}{7} = V_{OS}(\text{LMP8272})$$

If the signal on pin 3 is scaled, attenuated or amplified, by a factor X , then the offset of the overall system will become:

$$\frac{(7V_{OS1}) \times (X) + (V_{OS2})}{7(X)} = V_{OS}(\text{LMP8272})$$

LIFETIME DRIFT

Input Offset Voltage is an electrical parameter which may drift over time. This drift, known as life time drift, is very common in operational amplifiers; however, its effect is more evident in precision amplifiers. This is due to the very low Input Offset Voltage specifications in these amplifiers.

Numerous reliability tests have been performed to characterize this drift for the LMP827X family of products. Prior to each long term reliability test the Input Offset Voltage of LMP827X was measured at room temperature. The LMP827X was then subjected to a preconditioning sequence consisting of a 16

hour bake at 125°C ; an unbiased 168 hour Temperature Humidity Storage Test, THST, at 85°C and 85% humidity; four passes of infra-red reflow with a maximum temperature of 260°C ; and finally one hundred 30 min Temperature Cycles, TMCL, between -65°C and 150°C (15 min at each temperature).

The long term reliability tests include Operating Life Time, OPL, performed at 150°C for an extended period of time; Temperature Humidity Bias Testing, THBT, at 85°C and 85% humidity for an extended period of time; and repeated cycles of TMCL.

The Offset Voltage was measured again after each reliability test at room temperature. The Offset Voltage Drift is the difference between the initial measurement, before preconditioning, and the later measurement, post preconditioning and reliability test.

Figure 2 below shows the offset voltage drift after preconditioning and 1000 hours of OPL

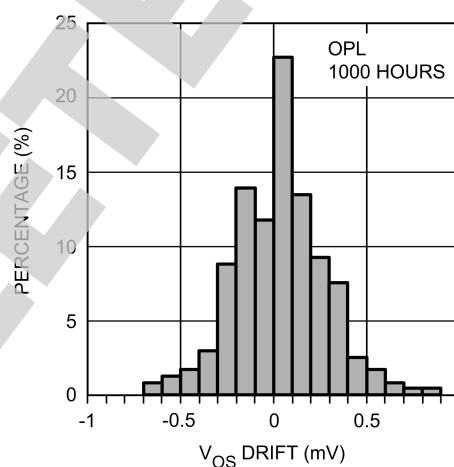

20150727

FIGURE 2. OPL Drift Histogram

Figure 3 shows the offset voltage drift after preconditioning and 1000 hours of THBT

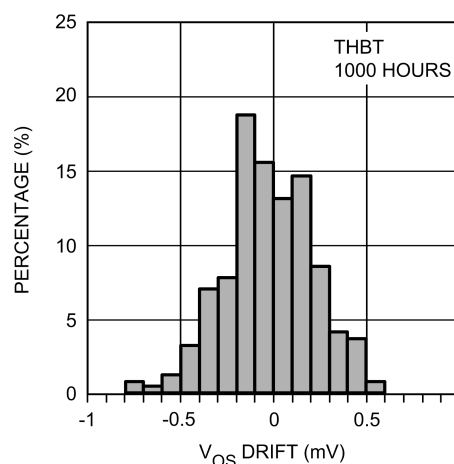

20150726

FIGURE 3. THBT Drift Histogram

Figure 4 shows the offset voltage drift after preconditioning and a total of 1000 TMCL cycles

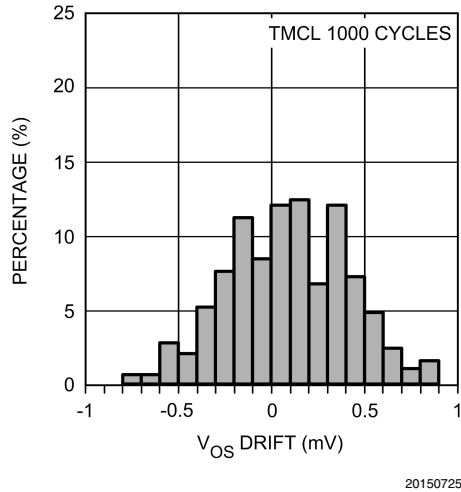

FIGURE 4. TMCL Drift Histogram

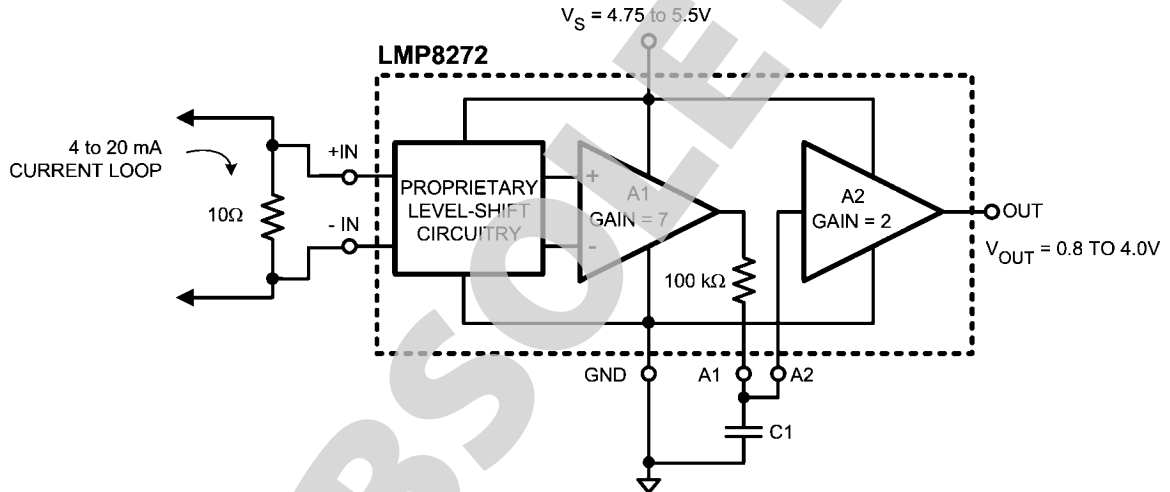

FIGURE 5. Current Loop Receiver

HIGH SIDE CURRENT SENSING

High side current measurement requires a differential amplifier with gain. Here the DC voltage source represents a common mode voltage with the +IN input at the supply voltage and the -IN input very close to the supply voltage. The LMP8272 can be used with a common mode voltage, V_{DC} in this case, of up to 16V.

The LMP8272 can be used for high side current sensing. The large common mode voltage range of this device allows it to

POWER SUPPLY DECOUPLING

In order to decouple the LMP8272 from AC noise on the power supply, it is recommended to use a 0.1 μF on the supply pin. It is best to use a 0.1 μF capacitor in parallel with a 10 μF capacitor. This will generate an AC path to ground for most frequency ranges and will greatly reduce the noise introduced by the power supply.

CURRENT LOOP RECEIVER

Many types of process control instrumentation use 4 to 20 mA transmitters to transmit the sensor's analog value to a central control room. The LMP8272 can be used as a current loop receiver as shown in Figure 5.

sense signals outside of its supply voltage range. Also, the LMP8272 has very high CMRR, which enables it to sense very small signals in presence of larger common mode signals. The system in Figure 6 couples these two characteristics of the LMP8272 in an automotive application. The signal through R_{S1} is detected and amplified by LMP8272 in the presence of a common mode signal of up to 16V with highest accuracy.

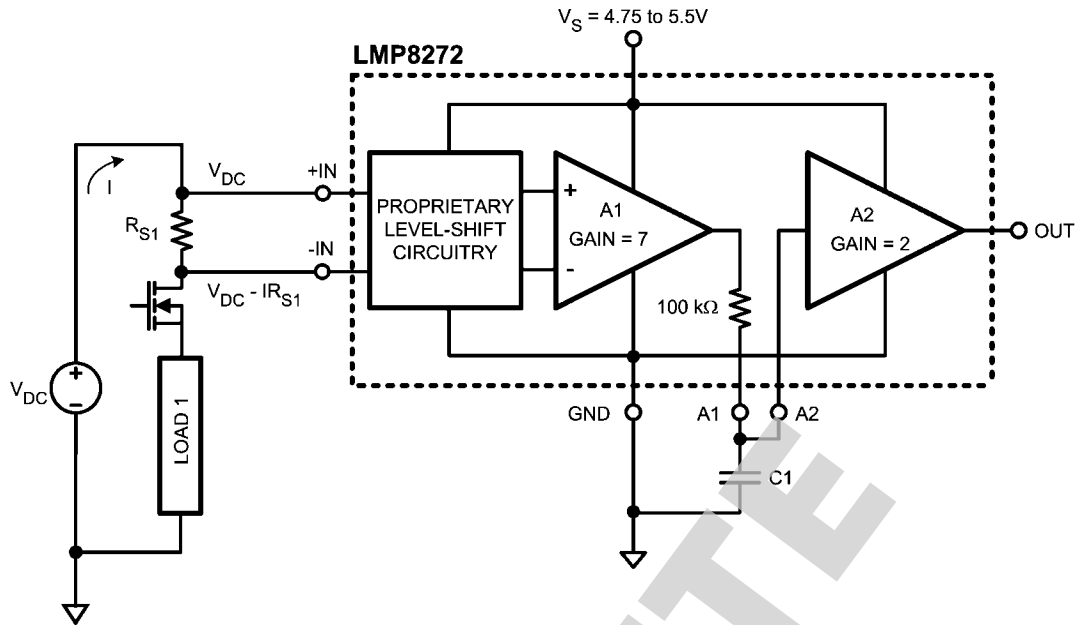

20150729

FIGURE 6. High Side Current Sensing

LOW SIDE CURRENT SENSING

Low side current measurements can cause a problem for operational amplifiers by exceeding the negative common mode voltage limit of the device. In *Figure 7*, the load current is returning to the power source through a common connection that has a parasitic resistance. The voltage drop across the parasitic resistances can cause the ground connection of the

measurement circuits to be at a positive voltage with respect to the common side of the sense resistor. This will result in one or both of the inputs being negative with respect to the circuit's ground. The LMP8272 has a wide extended input common mode voltage range of $-2V$ to $16V$ and will function in this condition.

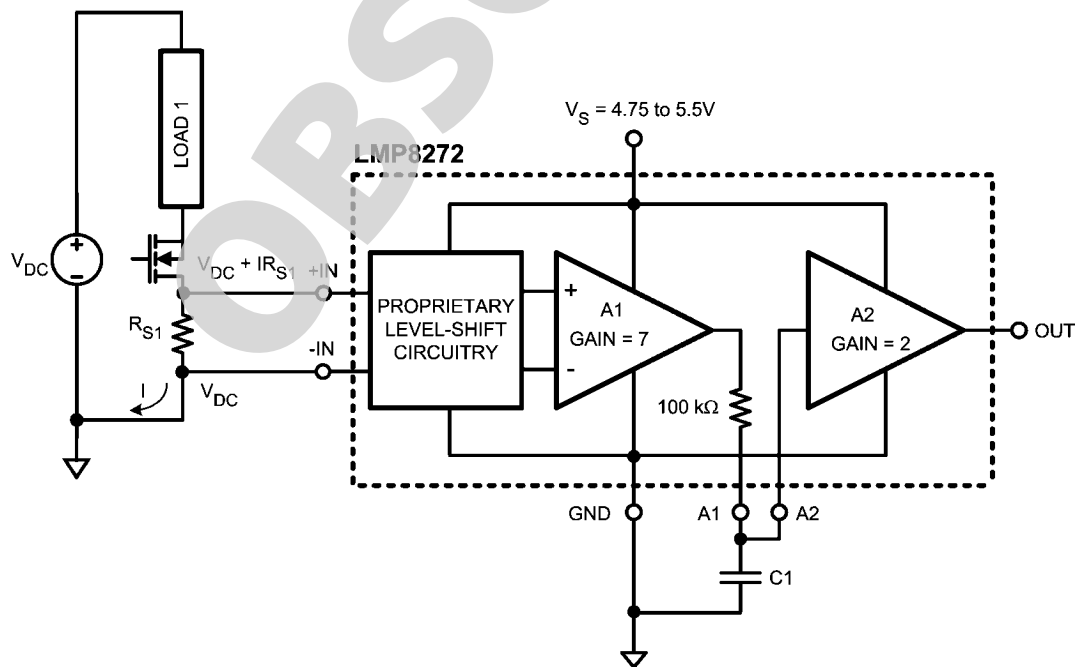

20150730

FIGURE 7. Low Side Current Sensing

SECOND ORDER LOW-PASS FILTER

The LMP8272 can be effectively used to build a second order Sallen-Key low pass filter. The general filter is shown in [Figure 8](#).

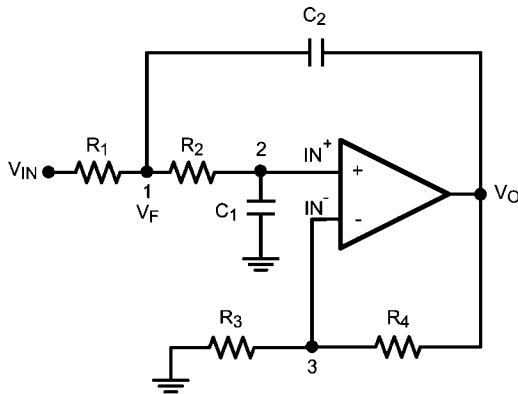

20150731

FIGURE 8. Second Order Low-Pass Filter

With the general transfer function:

$$\frac{V_O}{V_{IN}} = \frac{K}{M - KN} \tag{1}$$

Where:

$$M = s^2 C_1 C_2 R_1 R_2 + s(R_1 C_1 + R_1 C_2 + C_1 R_2) + 1$$

$$N = s C_2 R_1$$

and

$$\frac{1}{K} = \frac{1}{A_{VOL}} + \frac{R_3}{R_3 + R_4}$$

K represents the sum of DC closed loop gain and the non-ideality behavior of the operational amplifier. Assuming ideal behavior, the equation for K reduces simply to DC gain, which is set to +2 for the LMP8272.

The LMP8272 can be used to realize this configuration as shown in [Figure 9](#):

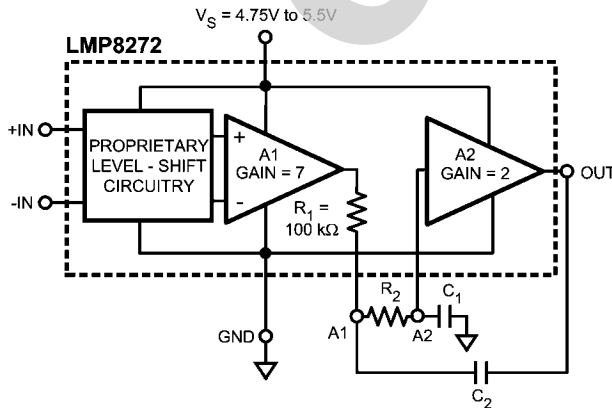

20150753

FIGURE 9. Low-Pass Filter With LMP8272

Using [Equation 1](#), the filter parameters can be calculated as follows:

$$\omega_o = \frac{1}{\sqrt{R_1 R_2 C_1 C_2}}$$

$$f_c = \frac{1}{2\pi \sqrt{R_1 R_2 C_1 C_2}}$$

$$Q = \frac{\sqrt{R_1 R_2 C_1 C_2}}{R_1 C_1 + R_2 C_1 + (1-K)R_1 C_2}$$

for the LMP8270, $R_1 = 100 \text{ k}\Omega$. Setting $R_1 = R_2$ and $C_1 = C_2$ results in a low-pass filter with $Q = 1$. Since values of resistors are predetermined, the corner frequency of this implementation of the filter depends on the capacitor values.

GAINS OTHER THAN 14

The LMP8272 has an internal gain of +14; however, this gain can be modified. The signal path between the two amplifiers is available as external pins.

GAINS LESS THAN 14

[Figure 10](#) shows the configuration used to reduce the LMP8272 gain.

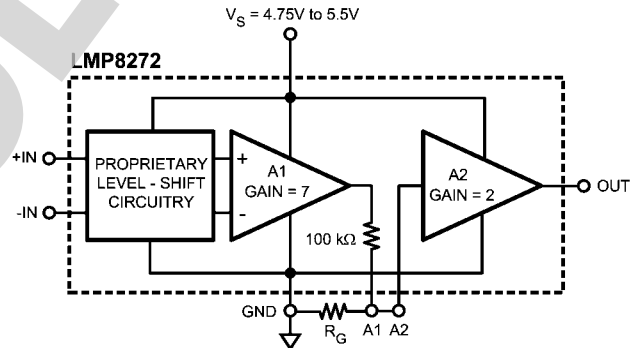

20150747

FIGURE 10. Gains Less Than 14

Where:

$$\text{GAIN (NEW)} = \frac{14 R_G}{R_G + 100 \text{ k}\Omega}$$

and

$$R_G = (100 \text{ k}\Omega) \frac{\text{GAIN (NEW)}}{14 - \text{GAIN (NEW)}}$$

GAINS GREATER THAN 14

A higher gain can be achieved by using positive feedback on the second stage amplifier, A2, of LMP8272. [Figure 11](#) shows the configuration.

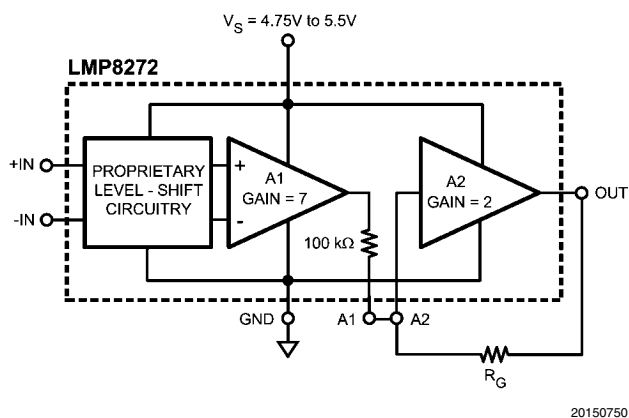

20150750

FIGURE 11. Gains Greater than 14

The total gain is given by:

$$\text{GAIN (NEW)} = \frac{14 R_G}{R_G - 100 \text{ k}\Omega} \quad (2)$$

Which can be rearranged to calculate R_G :

$$R_G = (100 \text{ k}\Omega) \frac{\text{GAIN (NEW)}}{\text{GAIN (NEW)} - 14}$$

The inverting gain of the second amplifier is set at 2, giving a total system gain of 14. The non-inverting gain which is achieved through positive feedback can be less than or equal to this gain without any issues. This implies a total system gain of 28 or less is easily achievable. Once the positive gain surpasses the negative gain, the system might oscillate.

As the value of gain resistor, R_G , approaches that of the internal 100 kΩ resistor, maintaining gain accuracy will become more challenging. This is because Gain (new) is inversely proportional to $(R_G - 100 \text{ k}\Omega)$, see [Equation 2](#). As $R_G \rightarrow 100 \text{ k}\Omega$, the denominator of [Equation 2](#) gets smaller. This smaller value will be comparable to the tolerance of the 100 kΩ resistor and R_G and hence the gain will be dominated by accuracy level of these resistors and the gain tolerance will be determined by the tolerance of the external resistor used for R_G and the 3% tolerance of the internal 100 kΩ resistor.

Physical Dimensions inches (millimeters) unless otherwise noted

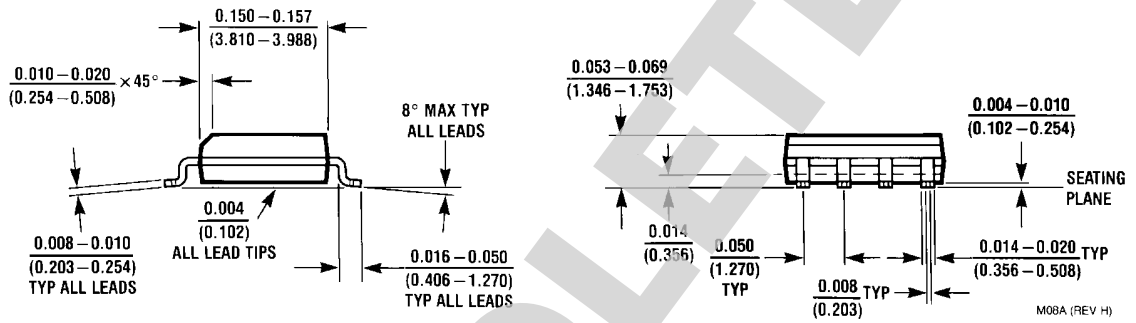
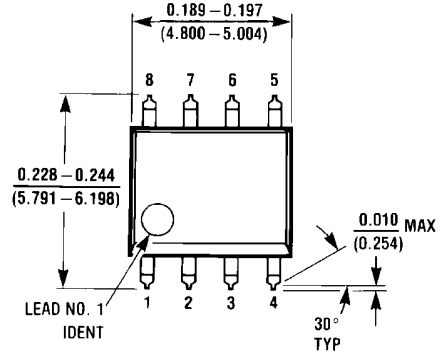

8-Pin SOIC
NSC Package Number M08A

OBSOLETE

Notes

LMP8272

OBSOLETE

Notes

For more National Semiconductor product information and proven design tools, visit the following Web sites at:
www.national.com

Products		Design Support	
Amplifiers	www.national.com/amplifiers	WEBENCH® Tools	www.national.com/webench
Audio	www.national.com/audio	App Notes	www.national.com/appnotes
Clock and Timing	www.national.com/timing	Reference Designs	www.national.com/refdesigns
Data Converters	www.national.com/adc	Samples	www.national.com/samples
Interface	www.national.com/interface	Eval Boards	www.national.com/evalboards
LVDS	www.national.com/lvds	Packaging	www.national.com/packaging
Power Management	www.national.com/power	Green Compliance	www.national.com/quality/green
Switching Regulators	www.national.com/switchers	Distributors	www.national.com/contacts
LDOs	www.national.com/ldo	Quality and Reliability	www.national.com/quality
LED Lighting	www.national.com/led	Feedback/Support	www.national.com/feedback
Voltage References	www.national.com/vref	Design Made Easy	www.national.com/easy
PowerWise® Solutions	www.national.com/powerwise	Applications & Markets	www.national.com/solutions
Serial Digital Interface (SDI)	www.national.com/sdi	Mil/Aero	www.national.com/milaero
Temperature Sensors	www.national.com/tempensors	SolarMagic™	www.national.com/solarmagic
PLL/VCO	www.national.com/wireless	PowerWise® Design University	www.national.com/training

THE CONTENTS OF THIS DOCUMENT ARE PROVIDED IN CONNECTION WITH NATIONAL SEMICONDUCTOR CORPORATION ("NATIONAL") PRODUCTS. NATIONAL MAKES NO REPRESENTATIONS OR WARRANTIES WITH RESPECT TO THE ACCURACY OR COMPLETENESS OF THE CONTENTS OF THIS PUBLICATION AND RESERVES THE RIGHT TO MAKE CHANGES TO SPECIFICATIONS AND PRODUCT DESCRIPTIONS AT ANY TIME WITHOUT NOTICE. NO LICENSE, WHETHER EXPRESS, IMPLIED, ARISING BY ESTOPPEL OR OTHERWISE, TO ANY INTELLECTUAL PROPERTY RIGHTS IS GRANTED BY THIS DOCUMENT.

TESTING AND OTHER QUALITY CONTROLS ARE USED TO THE EXTENT NATIONAL DEEMS NECESSARY TO SUPPORT NATIONAL'S PRODUCT WARRANTY. EXCEPT WHERE MANDATED BY GOVERNMENT REQUIREMENTS, TESTING OF ALL PARAMETERS OF EACH PRODUCT IS NOT NECESSARILY PERFORMED. NATIONAL ASSUMES NO LIABILITY FOR APPLICATIONS ASSISTANCE OR BUYER PRODUCT DESIGN. BUYERS ARE RESPONSIBLE FOR THEIR PRODUCTS AND APPLICATIONS USING NATIONAL COMPONENTS. PRIOR TO USING OR DISTRIBUTING ANY PRODUCTS THAT INCLUDE NATIONAL COMPONENTS, BUYERS SHOULD PROVIDE ADEQUATE DESIGN, TESTING AND OPERATING SAFEGUARDS.

EXCEPT AS PROVIDED IN NATIONAL'S TERMS AND CONDITIONS OF SALE FOR SUCH PRODUCTS, NATIONAL ASSUMES NO LIABILITY WHATSOEVER, AND NATIONAL DISCLAIMS ANY EXPRESS OR IMPLIED WARRANTY RELATING TO THE SALE AND/OR USE OF NATIONAL PRODUCTS INCLUDING LIABILITY OR WARRANTIES RELATING TO FITNESS FOR A PARTICULAR PURPOSE, MERCHANTABILITY, OR INFRINGEMENT OF ANY PATENT, COPYRIGHT OR OTHER INTELLECTUAL PROPERTY RIGHT.

LIFE SUPPORT POLICY

NATIONAL'S PRODUCTS ARE NOT AUTHORIZED FOR USE AS CRITICAL COMPONENTS IN LIFE SUPPORT DEVICES OR SYSTEMS WITHOUT THE EXPRESS PRIOR WRITTEN APPROVAL OF THE CHIEF EXECUTIVE OFFICER AND GENERAL COUNSEL OF NATIONAL SEMICONDUCTOR CORPORATION. As used herein:

Life support devices or systems are devices which (a) are intended for surgical implant into the body, or (b) support or sustain life and whose failure to perform when properly used in accordance with instructions for use provided in the labeling can be reasonably expected to result in a significant injury to the user. A critical component is any component in a life support device or system whose failure to perform can be reasonably expected to cause the failure of the life support device or system or to affect its safety or effectiveness.

National Semiconductor and the National Semiconductor logo are registered trademarks of National Semiconductor Corporation. All other brand or product names may be trademarks or registered trademarks of their respective holders.

Copyright© 2011 National Semiconductor Corporation

For the most current product information visit us at www.national.com



www.national.com

**National Semiconductor
Americas Technical
Support Center**
Email: support@nsc.com
Tel: 1-800-272-9959

**National Semiconductor Europe
Technical Support Center**
Email: europe.support@nsc.com

**National Semiconductor Asia
Pacific Technical Support Center**
Email: ap.support@nsc.com

**National Semiconductor Japan
Technical Support Center**
Email: jpn.feedback@nsc.com

IMPORTANT NOTICE

Texas Instruments Incorporated and its subsidiaries (TI) reserve the right to make corrections, modifications, enhancements, improvements, and other changes to its products and services at any time and to discontinue any product or service without notice. Customers should obtain the latest relevant information before placing orders and should verify that such information is current and complete. All products are sold subject to TI's terms and conditions of sale supplied at the time of order acknowledgment.

TI warrants performance of its hardware products to the specifications applicable at the time of sale in accordance with TI's standard warranty. Testing and other quality control techniques are used to the extent TI deems necessary to support this warranty. Except where mandated by government requirements, testing of all parameters of each product is not necessarily performed.

TI assumes no liability for applications assistance or customer product design. Customers are responsible for their products and applications using TI components. To minimize the risks associated with customer products and applications, customers should provide adequate design and operating safeguards.

TI does not warrant or represent that any license, either express or implied, is granted under any TI patent right, copyright, mask work right, or other TI intellectual property right relating to any combination, machine, or process in which TI products or services are used. Information published by TI regarding third-party products or services does not constitute a license from TI to use such products or services or a warranty or endorsement thereof. Use of such information may require a license from a third party under the patents or other intellectual property of the third party, or a license from TI under the patents or other intellectual property of TI.

Reproduction of TI information in TI data books or data sheets is permissible only if reproduction is without alteration and is accompanied by all associated warranties, conditions, limitations, and notices. Reproduction of this information with alteration is an unfair and deceptive business practice. TI is not responsible or liable for such altered documentation. Information of third parties may be subject to additional restrictions.

Resale of TI products or services with statements different from or beyond the parameters stated by TI for that product or service voids all express and any implied warranties for the associated TI product or service and is an unfair and deceptive business practice. TI is not responsible or liable for any such statements.

TI products are not authorized for use in safety-critical applications (such as life support) where a failure of the TI product would reasonably be expected to cause severe personal injury or death, unless officers of the parties have executed an agreement specifically governing such use. Buyers represent that they have all necessary expertise in the safety and regulatory ramifications of their applications, and acknowledge and agree that they are solely responsible for all legal, regulatory and safety-related requirements concerning their products and any use of TI products in such safety-critical applications, notwithstanding any applications-related information or support that may be provided by TI. Further, Buyers must fully indemnify TI and its representatives against any damages arising out of the use of TI products in such safety-critical applications.

TI products are neither designed nor intended for use in military/aerospace applications or environments unless the TI products are specifically designated by TI as military-grade or "enhanced plastic." Only products designated by TI as military-grade meet military specifications. Buyers acknowledge and agree that any such use of TI products which TI has not designated as military-grade is solely at the Buyer's risk, and that they are solely responsible for compliance with all legal and regulatory requirements in connection with such use.

TI products are neither designed nor intended for use in automotive applications or environments unless the specific TI products are designated by TI as compliant with ISO/TS 16949 requirements. Buyers acknowledge and agree that, if they use any non-designated products in automotive applications, TI will not be responsible for any failure to meet such requirements.

Following are URLs where you can obtain information on other Texas Instruments products and application solutions:

Products

Audio	www.ti.com/audio
Amplifiers	amplifier.ti.com
Data Converters	dataconverter.ti.com
DLP® Products	www.dlp.com
DSP	dsp.ti.com
Clocks and Timers	www.ti.com/clocks
Interface	interface.ti.com
Logic	logic.ti.com
Power Mgmt	power.ti.com
Microcontrollers	microcontroller.ti.com
RFID	www.ti-rfid.com
OMAP Mobile Processors	www.ti.com/omap
Wireless Connectivity	www.ti.com/wirelessconnectivity

Applications

Communications and Telecom	www.ti.com/communications
Computers and Peripherals	www.ti.com/computers
Consumer Electronics	www.ti.com/consumer-apps
Energy and Lighting	www.ti.com/energy
Industrial	www.ti.com/industrial
Medical	www.ti.com/medical
Security	www.ti.com/security
Space, Avionics and Defense	www.ti.com/space-avionics-defense
Transportation and Automotive	www.ti.com/automotive
Video and Imaging	www.ti.com/video

TI E2E Community Home Page

e2e.ti.com

Mailing Address: Texas Instruments, Post Office Box 655303, Dallas, Texas 75265
Copyright © 2011, Texas Instruments Incorporated