

Octal 3-State Inverters/ Line Drivers

These devices are designed to be used with 3-state memory address driver, and other bus-orientated systems.

- Output Drive Capability: 15 LSTTL Loads
- Outputs Directly Interface to CMOS, NMOS, and TTL
- Operating Voltage Range: 2 to 6 V for HC devices
- Low Input Current: 1 μ A
- DC, AC parameters guaranteed from -55°C to 125°C

DV74HC240A, 241A, 244A DV74HCT240A, 241A, 244A

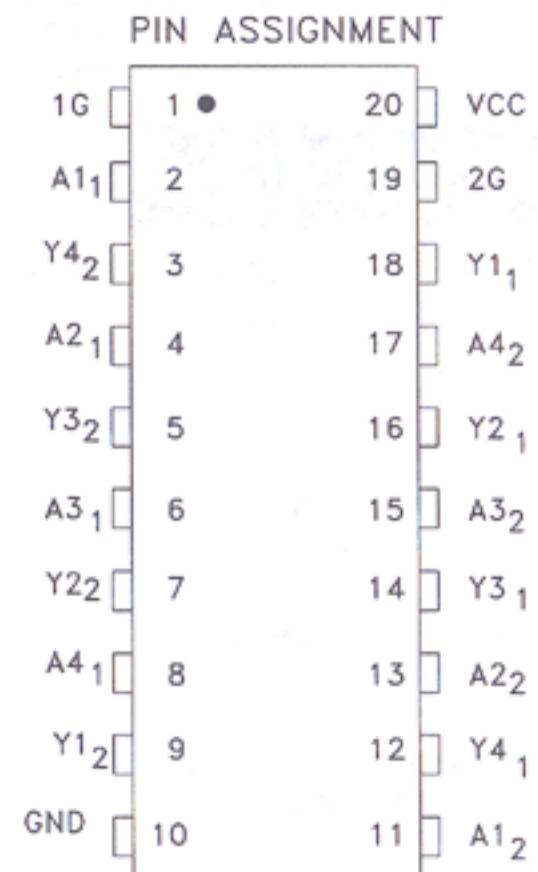
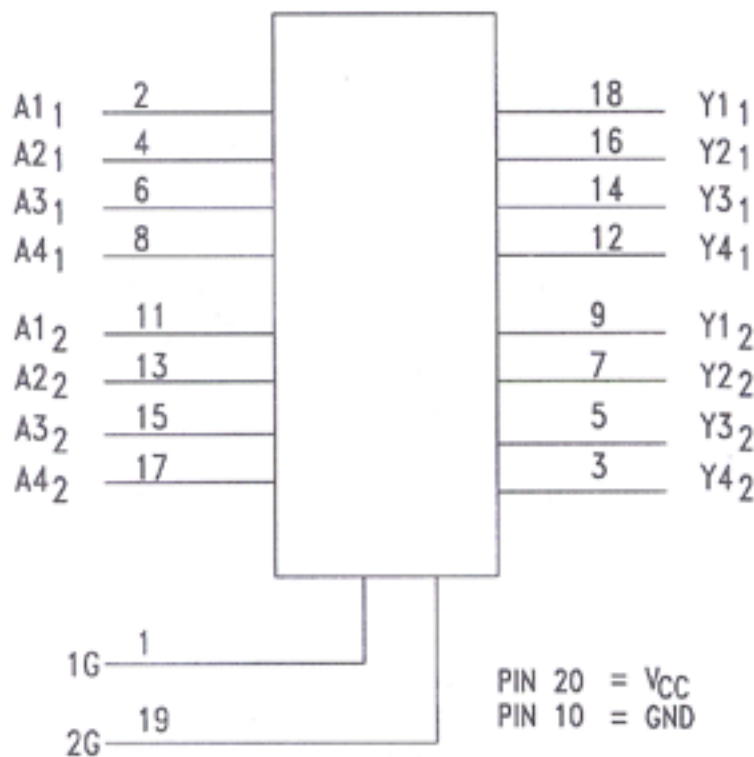
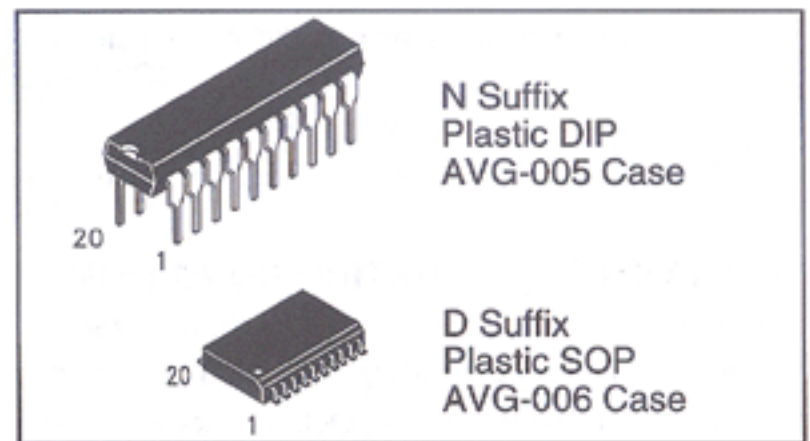

NOTE: Refer to the appropriate Truth Tables for signal phases.

DV74HC240-DV74HCT240
TRUTH TABLE

Inputs		Output Y
Gn	An	Y
L	L	H
L	H	L
H	X	Z

DV74HC241-DV74HCT241
TRUTH TABLE

Inputs		Output Y	Inputs		Output Y
1G	An	Y	2G	An	Y
L	L	L	H	L	L
L	H	H	H	H	H
H	X	Z	L	X	Z

DV74HC244-DV74HCT244
TRUTH TABLE

Inputs		Output Y
Gn	An	Y
L	L	L
L	H	H
H	X	Z

H = High Logic Level
L = Low Logic Level
Z = High Impedance State
X = Don't Care

240, 241, 244

ABSOLUTE MAXIMUM RATINGS

Maximum ratings are those values beyond which damage to the device may occur.

Symbol	Parameter	Value	Unit
V _{CC}	DC Supply Voltage (Referenced to GND)	-0.5 to +7.0	V
V _{IN}	DC Input Voltage (Referenced to GND)	-1.5 to V _{CC} +1.5	V
V _{OUT}	DC Output Voltage (Referenced to GND)	-0.5 to V _{CC} +0.5	V
I _{IN}	DC Input Current, per Pin	± 20	mA
I _{OUT}	DC Output Current, per Pin	± 25	mA
I _{CC}	DC Supply Current, V _{CC} and GND Pins	± 75	mA
P _D	Power Dissipation in Still Air, Plastic DIP SOP Package	750 500	mW
T _{STG}	Storage Temperature Range	-65 to +150	°C
TL	Lead Temperature, 1mm from Case for 10 Seconds	260	°C

GUARANTEED OPERATING CONDITIONS

Symbol	Parameter	Min	Max	Unit
V _{CC}	DC Supply Voltage, HC (HCT), Referenced to GND	2.0 (4.5)	6.0 (5.5)	V
V _{IN} , V _{OUT}	DC Input Voltage, Output Voltage, Referenced to GND	0	V _{CC}	V
T _A	Ambient Temperature	-55	+125	°C
t _r , t _f	Input Rise and Fall Time: HC: V _{CC} =2.0V HCT: V _{CC} =5.5V / HC: V _{CC} =4.5V HC: V _{CC} =6.0V	0 0 0	1000 500 400	ns

HC-240A, 241A, 244A

DC ELECTRICAL CHARACTERISTICS

Symbol	Parameter	Conditions	V _{CC} V	Guaranteed Limits			Unit
				25°C to -55°C	≤85°C	≤125°C	
V _{IH}	Minimum High-Level Input Voltage	V _{OUT} = 0.1 V, I _{OUT} ≤ 20 μA	2.0	1.5	1.5	1.5	V
			4.5	3.15	3.15	3.15	
			6.0	4.2	4.2	4.2	
V _{IL}	Maximum Low-Level Input Voltage	V _{OUT} = V _{CC} - 0.1V I _{OUT} ≤ 20 μA	2.0	0.5	0.5	0.5	V
			4.5	1.35	1.35	1.35	
			6.0	1.8	1.8	1.8	
V _{OH}	Minimum High-Level Output Voltage	V _{IN} = V _{IH} or V _{IL} I _{OUT} ≤ 20 μA	2.0	1.9	1.9	1.9	V
			4.5	4.4	4.4	4.4	
		V _{IN} = V _{IH} or V _{IL} , I _{OUT} ≤ 6.0mA I _{OUT} ≤ 7.8 mA	4.5	3.98	3.84	3.7	
			6.0	5.48	5.34	5.2	
V _{OL}	Maximum Low Level Output Voltage	V _{IN} = V _{IH} or V _{IL} I _{OUT} ≤ 20 μA	2.0	0.1	0.1	0.1	V
			4.5	0.1	0.1	0.1	
		V _{IN} = V _{IH} or V _{IL} , I _{OUT} ≤ 6.0mA I _{OUT} ≤ 7.8 mA	4.5	0.26	0.33	0.40	V
			6.0	0.26	0.33	0.40	
I _{IN}	Maximum Input Leakage Current	V _{IN} = V _{CC} or GND	6.0	± 0.1	± 1.0	± 1.0	μA
I _{OZ}	Maximum Three-State Leakage Current	Output in High-Impedance State V _{IN} = V _{IL} or V _{IH} V _{OUT} = V _{CC} or GND	6.0	± 0.5	± 5.0	± 10.0	μA
I _{CC}	Maximum Quiescent Supply Current	V _{IN} = V _{CC} or GND, I _{OUT} = 0 μA (Per Package)	6.0	4.0	40	160	μA

240, 241, 244

AC ELECTRICAL CHARACTERISTICS over full operating conditions ($C_L=50\text{pF}$, Input $t_f=t_r=6\text{ns}$)

Symbol	Parameter	V _{CC} V	Guaranteed Limit			Unit
			25°C to -55°C	≤85°C	≤125°C	
t _{PLH} , t _{PHL}	Maximum Propagation Delay Time, Input to Output HC240A	2.0	80	100	120	ns
		4.5	16	20	24	
		6.0	14	17	20	
t _{PLH} , t _{PHL}	Maximum Propagation Delay Time, Input to Output HC241	2.0	90	115	135	ns
		4.5	18	23	27	
		6.0	15	20	23	
t _{PLH} , t _{PHL}	Maximum Propagation Delay Time, Input to Output HC244	2.0	96	115	135	ns
		4.5	18	23	27	
		6.0	15	20	23	
t _{PLZ} , t _{PHZ}	Maximum Propagation Delay Time, Output Disable to Output	2.0	110	140	165	ns
		4.5	22	28	33	
		6.0	19	24	28	
t _{PZL} , t _{PZH}	Maximum Propagation Delay Time, Output Enable to Output	2.0	110	140	165	ns
		4.5	22	28	33	
		6.0	19	24	28	
t _{TLH} , t _{THL}	Maximum Output Transition Time Any Output	2.0	60	75	90	ns
		4.5	12	15	18	
		6.0	10	13	15	
C _{IN}	Maximum Input Capacitance	—	10	10	10	pF
C _{OUT}	Maximum Three-State Output Capacitance (Output in High-Impedance)	—	15	15	15	pF

C _{PD}	Power Dissipation Capacitance (Per Gate) Used to determine the no-load dynamic power consumption, $P_D = C_{PD} V_{CC}^2 f + I_{CC} V_{CC}$	Typical @ 25°C, V _{CC} = 5 V			Unit
		HC 240A	HC241A, HC244A		
			32		pF
			34		

HCT-240A, 241, 244
DC ELECTRICAL CHARACTERISTICS

Symbol	Parameter	Conditions	V _{CC} V	Guaranteed Limits			Unit
				25°C to -55°C	≤85°C	≤125°C	
V _{IH}	Minimum High-Level Input Voltage	V _{OUT} = 0.1 V, I _{OUT} = 0 μA or V _{OUT} = V _{CC} - 0.1 V	4.5	2.0	2.0	2.0	V
			5.5	2.0	2.0	2.0	
V _{IL}	Maximum Low-Level Input Voltage	V _{OUT} = 0.1 V, I _{OUT} = 0 μA or V _{OUT} = V _{CC} - 0.1 V	4.5	0.8	0.8	0.8	V
			5.5	0.8	0.8	0.8	
V _{OH}	Minimum High-Level Output Voltage	V _{IN} = V _{IH} or V _{IL} I _{OUT} ≤ 20 μA	4.5	4.4	4.4	4.4	V
			5.5	5.4	5.4	5.4	
		V _{IN} = V _{IH} or V _{IL} I _{OUT} < 6.0 mA	5.5	3.98	3.84	3.7	
V _{OL}	Maximum Low Level Output Voltage	V _{IN} = V _{IH} or V _{IL} I _{OUT} ≤ 20 μA	4.5	0.1	0.1	0.1	V
			5.5	0.1	0.1	0.1	
		V _{IN} = V _{IH} or V _{IL} , I _{OUT} ≤ 4.0 mA I _{OUT} ≤ 6.0 mA	4.5	0.26	0.33	0.4	
I _{IN}	Maximum Input Leakage Current	V _{IN} = V _{CC} or GND	5.5	± 0.1	± 1	± 1	μA

Symbol	Parameter	Conditions	V _{CC} V	Guaranteed Limits			Unit
				25°C to -55°C	≤85°C	≤125°C	
I _{OZ}	Maximum Three-State Leakage Current	Output in High-Impedance State V _{IN} =V _{IL} or V _{IH} V _{OUT} =V _{CC} or GND	6.0	± 0.5	± 5.0	± 10.0	μA
I _{CC}	Maximum Quiescent Supply Current (Per Package)	V _{IN} = V _{CC} or GND I _{OUT} ≤ 0 μA	5.5	8	80	160	μA
ΔI _{CC}	Additional Quiescent Supply Current	V _{IN} =2.4V, Any One Input V _{IN} =V _{CC} or GND, Other Inputs I _{OUT} =0μA	5.5	≥-55°C 2.9	25°C to 125°C 2.4		mA

AC ELECTRICAL CHARACTERISTICS over full operating conditions

Symbol	Parameter (C _L =50pF, Input t _r =t _f =6ns) (V _{CC} = 5V ± 10%)		Guaranteed Limit			Unit
			25°C to -55°C	≤85°C	≤125°C	
t _{PLH} , t _{PHL}	Maximum Propagation Delay Time, Input to Output	HCT 240A	20	25	30	ns
t _{PLZ} , t _{PHZ}	Maximum Propagation Delay Time, Output Disable to Output		28	35	42	ns
t _{PZL} , t _{PZH}	Maximum Propagation Delay Time, Output Enable to Output		25	31	38	ns
t _{PLH} , t _{PHL}	Maximum Propagation Delay Time, Input to Output	HCT 241A	23	29	35	ns
t _{PLZ} , t _{PHZ}	Maximum Propagation Delay Time, Output Disable to Output		30	38	45	ns
t _{PZL} , t _{PZH}	Maximum Propagation Delay Time, Output Enable to Output		26	33	39	ns
t _{PLH} , t _{PHL}	Maximum Propagation Delay Time, Input to Output	HCT 244A	20	25	30	ns
t _{PLZ} , t _{PHZ}	Maximum Propagation Delay Time, Output Disable to Output		26	33	39	ns
t _{PZL} , t _{PZH}	Maximum Propagation Delay Time, Output Enable to Output		22	28	33	ns
t _{TLH} , t _{THL}	Maximum Output Transition Time Any Output		12	15	18	ns
C _{IN}	Maximum Input Capacitance		10	10	10	pF
C _{OUT}	Maximum Three-State Output Capacitance (Output in High Impedance State)		15	15	15	pF
C _{PD}	Power Dissipation Capacitance (Per Gate) Used to determine the no-load dynamic power consumption P _D = C _{PD} V _{CC} ² f + I _{CC} V _{CC}		Typical @ 25°C, V _{CC} = 5 V			pF
			55			

SWITCHING WAVEFORMS

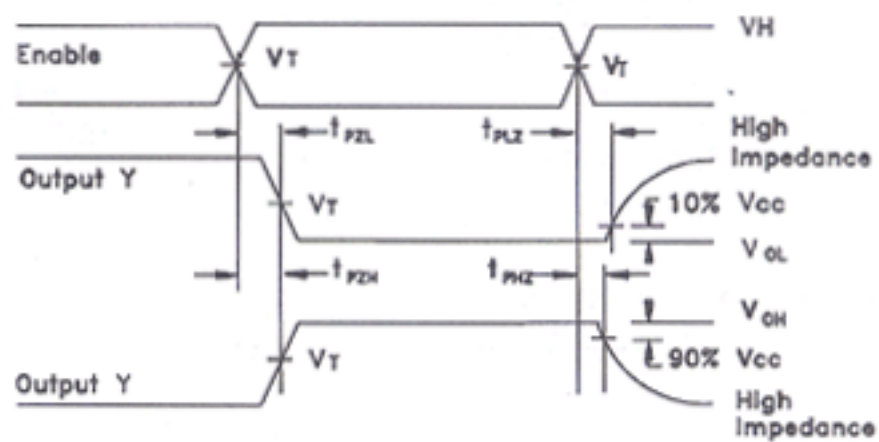
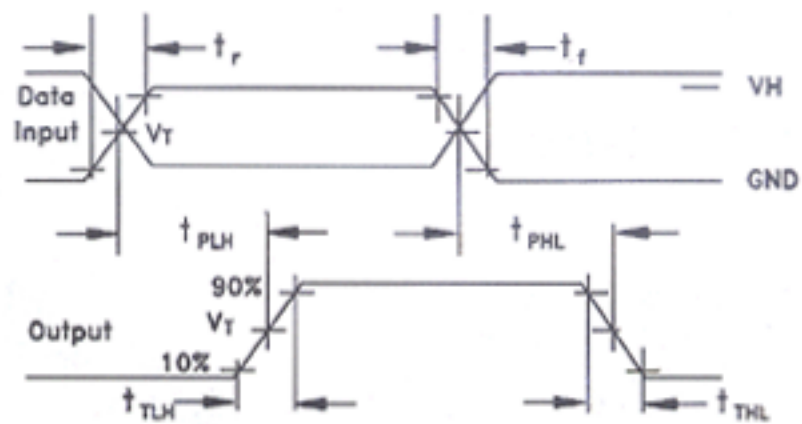

Input threshold Voltage, $V_T = 50\% V_{CC}$ for HC, 1.3V for HCT
 $V_H = V_{CC}$ for HC, 3V for HCT

240, 241, 244