

**CUSTOMER COPY**

Note:

1. Material: Housing Nylon46 94 V-0  
Terminal Phosphor Bronze

REV	ECN NO.	APP.	DATE
A	NEW DESIGN		

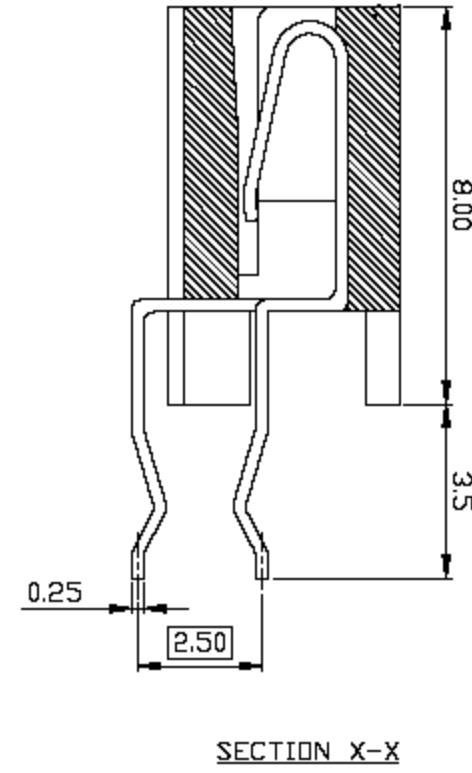
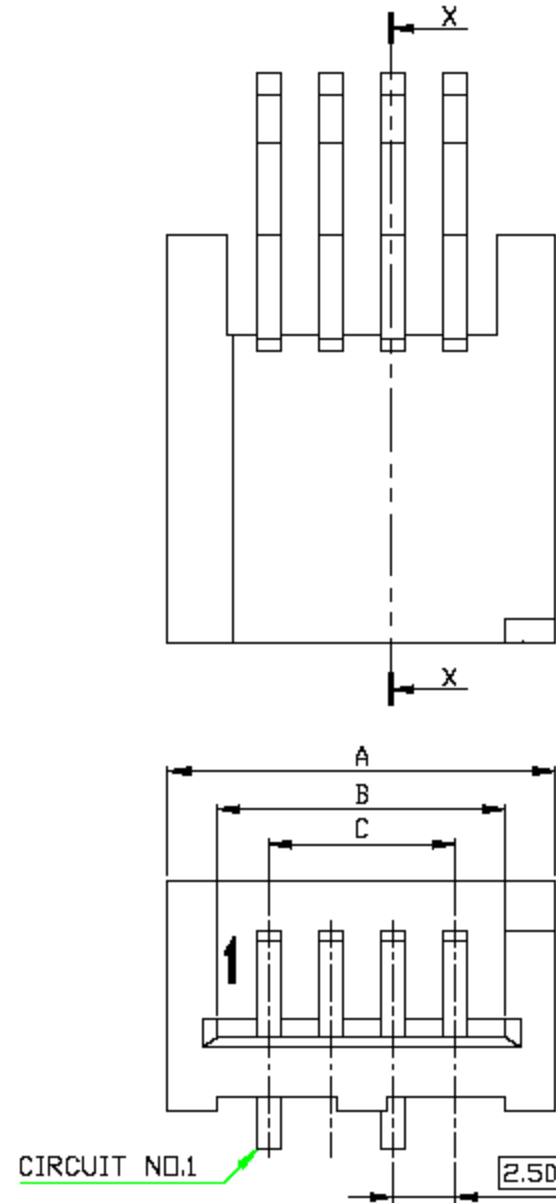

**ORDER INFORMATION**

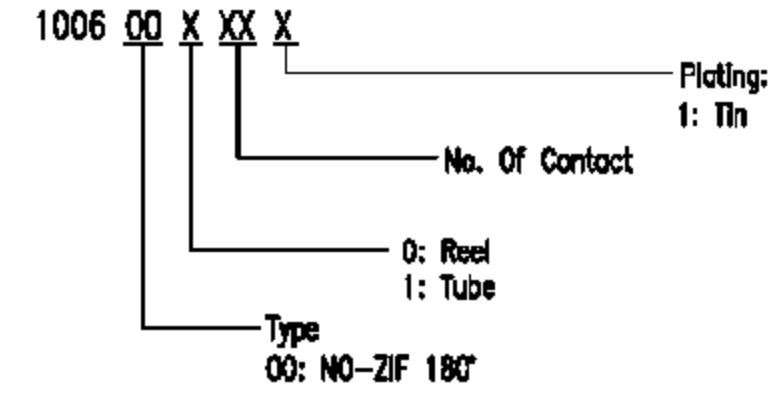

CKT	DIMENSION		
	A	B	C
3	7.15	5.10	2.50
4	8.40	6.35	3.75
5	9.65	7.60	5.00
6	10.90	8.85	6.25
7	12.15	10.10	7.50
8	13.40	11.35	8.75
9	14.65	12.60	10.00
10	15.90	13.85	11.25
11	17.15	15.10	12.50
12	18.40	16.35	13.75
13	19.65	17.60	15.00
14	20.90	18.85	16.25
15	22.15	20.10	17.50
16	23.40	21.35	18.75
17	24.65	22.60	20.00
18	25.90	23.85	21.25
19	27.15	25.10	22.50
20	28.40	26.35	23.75
21	29.65	27.60	25.00
22	30.90	28.85	26.25
23	32.15	30.10	27.50
24	33.40	31.35	28.75
25	34.65	32.60	30.00
26	35.90	33.85	31.25
27	37.15	35.10	32.50
28	38.40	36.35	33.75
29	39.65	37.60	35.00
30	40.90	38.85	36.25
31	42.15	40.10	37.50
32	43.40	41.35	38.75
33	44.65	42.60	40.00

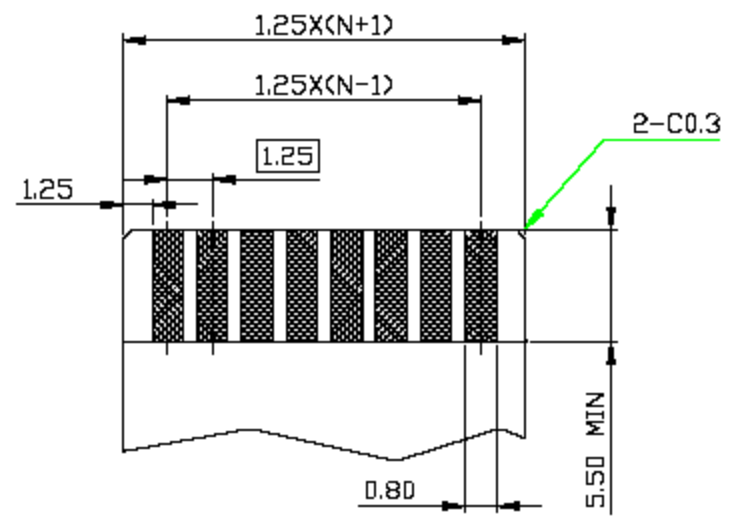
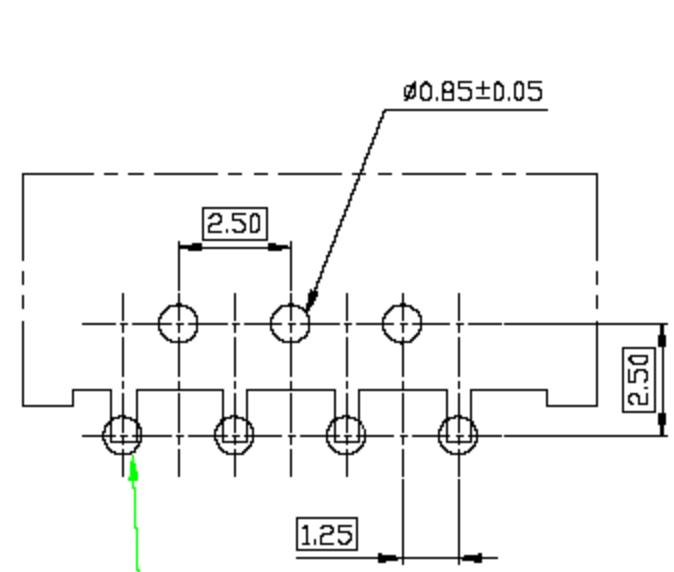

F.P.C. T=0.3±0.05  
TOLERANCE: 0.05mm

P.C.B. LAYOUT: COMPONENT SIDE  
T=1.60mm

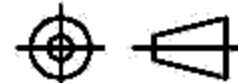
 <b>ACMELUX CO., LTD.</b> TEL:886-85124595 FAX:886-85124322		<b>TITLE:</b> 1.25mm NON ZIF FOR FPC/FPC		<b>PART NO:</b>
		<b>SCALE:</b> 0.0± 0.25 0.00± 0.20 0.000± 0.10	<b>UNIT:</b> MM	<b>APP BY:</b> HUNG
		<b>MATL:</b>	<b>DR BY:</b> ADER	A239
<b>DWG. NO.</b> C100600XXXX				