

74125, 74126, LS125A, LS126A Buffers

Quad 3-State Buffer Product Specification

FUNCTION TABLE '125, 'LS125A

INPUTS		OUTPUT
C	A	Y
L	L	L
L	H	H
H	X	(Z)

FUNCTION TABLE '126, 'LS126A

INPUTS		OUTPUT
C	A	Y
H	L	L
H	H	H
L	X	(Z)

H = HIGH voltage level
L = LOW voltage level
X = Don't care
(Z) = HIGH impedance (off)

TYPE	TYPICAL PROPAGATION DELAY	TYPICAL SUPPLY CURRENT (TOTAL)
74125	10ns	32mA
74LS125A	8ns	11mA
74126	10ns	36mA
74LS126A	9ns	12mA

ORDERING CODE

PACKAGES	COMMERCIAL RANGE $V_{CC} = 5V \pm 5\%$; $T_A = 0^\circ C$ to $+70^\circ C$
Plastic DIP	N74125N, N74LS125N N74126N, N74LS126N
Plastic SO	N74LS125AD

NOTE:

For information regarding devices processed to Military Specifications, see the Signetics Military Products Data Manual.

INPUT AND OUTPUT LOADING AND FAN-OUT TABLE

PINS	DESCRIPTION	74	74LS
All	Inputs	1ul	1LSul
All	Outputs	10ul	30LSul

NOTE:

Where a 74 unit load (ul) is understood to be $40\mu A I_{IH}$ and $-1.6mA I_{IL}$, and a 74LS unit load (LSul) is $20\mu A I_{IH}$ and $-0.4mA I_{IL}$.

PIN CONFIGURATION

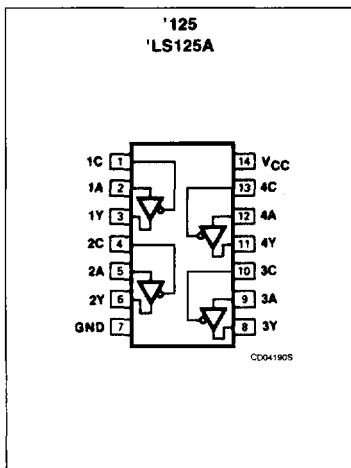

LOGIC SYMBOL

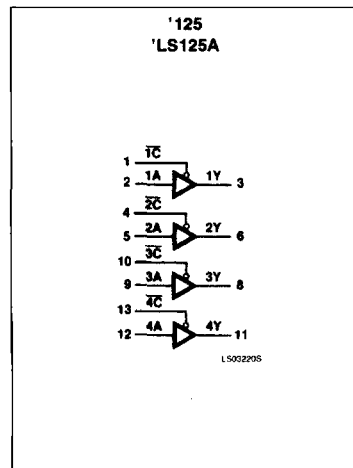

LOGIC SYMBOL (IEEE/IEC)

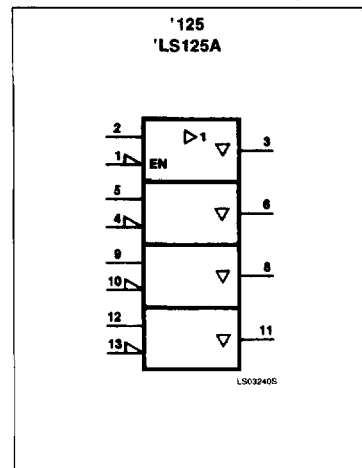

Buffers

74125, 74126, LS125A, LS126A

PIN CONFIGURATION

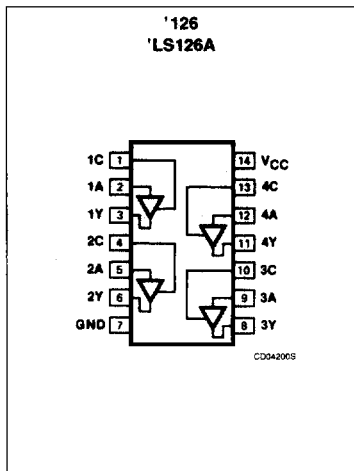

LOGIC SYMBOL

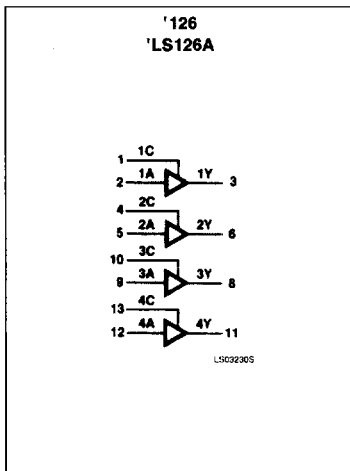

LOGIC SYMBOL (IEEE/IEC)

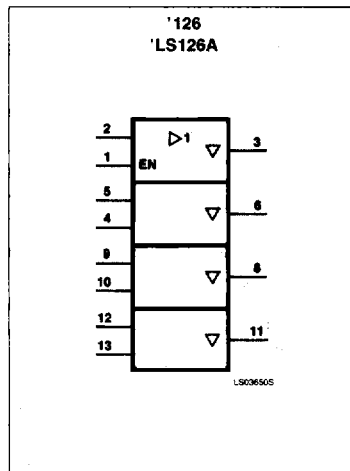

ABSOLUTE MAXIMUM RATINGS (Over operating free-air temperature range unless otherwise noted.)

PARAMETER	74	74LS	UNIT
V _{CC} Supply voltage	7.0	7.0	V
V _{IN} Input voltage	-0.5 to +5.5	-0.5 to +7.0	V
I _{IN} Input current	-30 to +5	-30 to +1	mA
V _{OUT} Voltage applied to output in HIGH output state	-0.5 to +V _{CC}	-0.5 to +V _{CC}	V
T _A Operating free-air temperature range	0 to 70		°C

RECOMMENDED OPERATING CONDITIONS

PARAMETER	74			74LS			UNIT
	Min	Nom	Max	Min	Nom	Max	
V _{CC} Supply voltage	4.75	5.0	5.25	4.75	5.0	5.25	V
V _{IH} HIGH-level input voltage	2.0			2.0			V
V _{IL} LOW-level input voltage			+0.8			+0.8	V
I _{IK} Input clamp current			-12			-18	mA
I _{OH} HIGH-level output current			-5.2			-2.6	mA
I _{OL} LOW-level output current			16			24	mA
T _A Operating free-air temperature	0		70	0		70	°C

Buffers

74125, 74126, LS125A, LS126A

DC ELECTRICAL CHARACTERISTICS (Over recommended operating free-air temperature range unless otherwise noted.)

PARAMETER	TEST CONDITIONS ¹	74125 74126			74LS125A 74LS126A			UNIT	
		Min	Typ ²	Max	Min	Typ ²	Max		
V _{OH}	HIGH-level output voltage V _{CC} = MIN, V _{IH} = MIN, V _{IL} = MAX, I _{OH} = MAX	2.4	3.1		2.4			V	
V _{OL}	LOW-level output voltage V _{CC} = MIN, V _{IH} = MIN, V _{IL} = MAX	I _{OL} = MAX				0.4	0.35	0.5	V
		I _{OL} = 12mA (74LS)					0.25	0.4	V
V _{IK}	Input clamp voltage V _{CC} = MIN, I _I = I _{IK}			-1.5			-1.5	V	
I _{OZH}	Off-state output current, HIGH-level voltage applied V _{CC} = MAX, V _{IH} = MIN, V _{IL} = MAX, V _O = 2.4V			40			20	μA	
I _{OZL}	Off-state output current, LOW-level voltage applied V _{CC} = MAX, V _{IH} = MIN, V _{IL} = MAX, V _O = 0.4V			-40			-20	μA	
I _I	Input current at maximum input voltage V _{CC} = MAX	V _I = 5.5V			1.0				mA
		V _I = 7.0V						0.1	mA
I _{IH}	HIGH-level input current V _{CC} = MAX	V _I = 2.4V			40				μA
		V _I = 2.7V						20	μA
I _{IL}	LOW-level input current V _{CC} = MAX, V _I = 0.4V			-1.6			-0.4	mA	
I _{OS}	Short-circuit output current ³ V _{CC} = MAX	-28		-70	-40		-130	mA	
I _{CC}	Supply current (total) V _{CC} = MAX	'125	32	54		11	20	mA	
		'126	36	62		12	22	mA	

NOTES:

- For conditions shown as MIN or MAX, use the appropriate value specified under recommended operating conditions for the applicable type.
- All typical values are at V_{CC} = 5V, T_A = 25°C.
- I_{OS} is tested with V_{OUT} = +0.5V and V_{CC} = V_{CC} MAX + 0.5V. Not more than one output should be shorted at a time and duration of the short circuit should not exceed one second.

Buffers

74125, 74126, LS125A, LS126A

AC WAVEFORMS

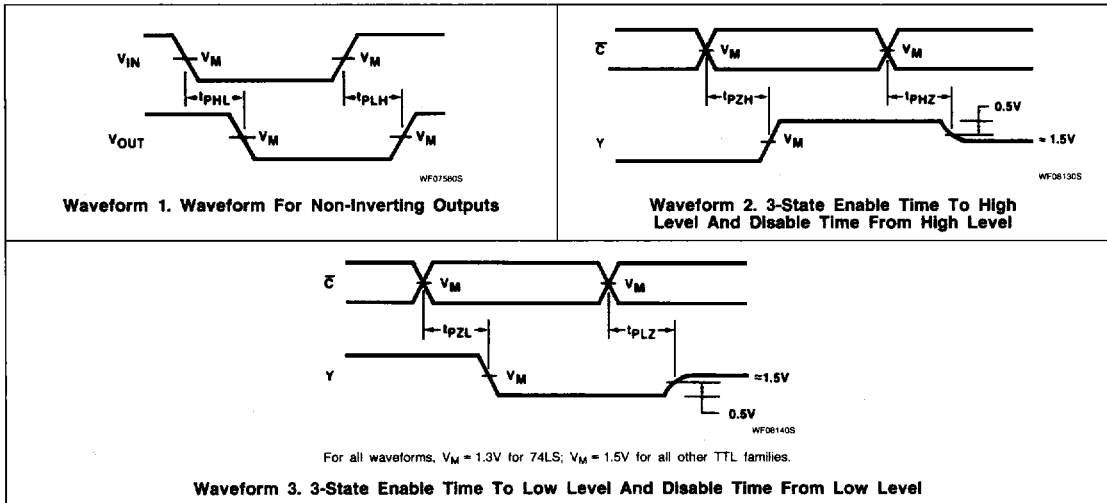

AC ELECTRICAL CHARACTERISTICS $T_A = 25^\circ C, V_{CC} = 5.0V$

PARAMETER	TEST CONDITIONS	74125		74LS125A		74126		74LS126A		UNIT
		$C_L = 50pF$ $R_L = 400\Omega$		$C_L = 45pF$ $R_L = 667\Omega$		$C_L = 50pF$ $R_L = 400\Omega$		$C_L = 45pF$ $R_L = 667\Omega$		
		Min	Max	Min	Max	Min	Max	Min	Max	
t_{PLH} t_{PHL}	Propagation delay Data to output	Waveform 1		13	15	13	13	15	15	ns
t_{PZH}	Enable to HIGH	Waveform 2		17	20	18	18	25	25	ns
t_{PZL}	Enable to LOW	Waveform 3		25	25	25	25	35	35	ns
t_{PHZ}	Disable from HIGH	Waveform 2, $C_L = 5pF$		8.0	20	16	16	25	25	ns
t_{PLZ}	Disable from LOW	Waveform 3, $C_L = 5pF$		12	20	18	18	25	25	ns

Buffers

74125, 74126, LS125A, LS126A

TEST CIRCUITS AND WAVEFORMS

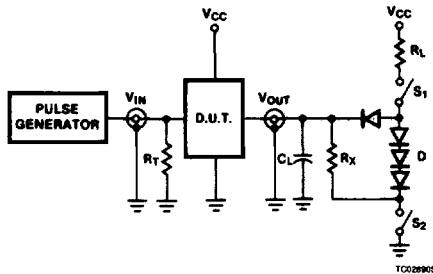

Test Circuit For 3-State Outputs

SWITCH POSITION

TEST	SWITCH 1	SWITCH 2
t_{PZH}	Open	Closed
t_{PZL}	Closed	Open
t_{PHZ}	Closed	Closed
t_{PLZ}	Closed	Closed

DEFINITIONS

R_L = Load resistor to V_{CC} ; see AC CHARACTERISTICS for value.
 C_L = Load capacitance includes jig and probe capacitance; see AC CHARACTERISTICS for value.
 R_T = Termination resistance should be equal to Z_{OUT} of Pulse Generators.
 D = Diodes are 1N916, 1N3064, or equivalent.
 t_{TLH} , t_{THL} Values should be less than or equal to the table entries.

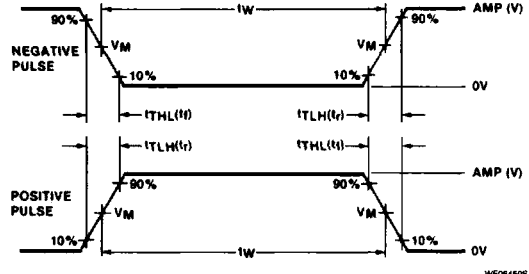

$V_M = 1.3V$ for 74LS; $V_M = 1.5V$ for all other TTL families.

Input Pulse Definition

FAMILY	INPUT PULSE REQUIREMENTS				
	Amplitude	Rep. Rate	Pulse Width	t_{TLH}	t_{THL}
74	3.0V	1MHz	500ns	7ns	7ns
74LS	3.0V	1MHz	500ns	15ns	6ns
74S	3.0V	1MHz	500ns	2.5ns	2.5ns