



CYPRESS

PRELIMINARY

CY7C1311V18
CY7C1313V18
CY7C1315V18

18-Mb QDR™-II SRAM 4-Word Burst Architecture

Features

- Separate Independent Read and Write Data Ports
 - Supports concurrent transactions
- 250-MHz Clock for High Bandwidth
- Four-word Burst for reducing address bus frequency
- Double Data Rate (DDR) interfaces on both Read and Write Ports (data transferred at 500 MHz) at 250 MHz
- Two input clocks (K and \bar{K}) for precise DDR timing
 - SRAM uses rising edges only
- Two output clocks (C and \bar{C}) accounts for clock skew and flight time mismatches
- Echo clocks (CQ and \bar{CQ}) simplify data capture in high speed systems
- Single multiplexed address input bus latches address inputs for both Read and Write ports
- Separate Port Selects for depth expansion
- Synchronous internally self-timed writes
- Available in $\times 8$, $\times 18$, and $\times 36$ configurations
- 1.8V core power supply with HSTL Inputs and Outputs
- 13 \times 15 mm 1.0-mm pitch FBGA package, 165-ball (11 \times 15 matrix)
- Variable drive HSTL output buffers
- Expanded HSTL output voltage (1.4V–1.9V)
- JTAG Interface
- On-chip Delay Lock Loop (DLL)

Configurations

CY7C1311V18–2M \times 8

CY7C1313V18–1M \times 18

CY7C1315V18–512K \times 36

Functional Description

The CY7C1311V18/CY7C1313V18/CY7C1315V18 are 1.8V Synchronous Pipelined SRAMs, equipped with QDR™-II architecture. QDR-II architecture consists of two separate ports to access the memory array. The Read port has dedicated Data Outputs to support Read operations and the Write Port has dedicated Data Inputs to support Write operations. QDR-II architecture has separate data inputs and data outputs to completely eliminate the need to “turn-around” the data bus required with common I/O devices. Access to each port is accomplished through a common address bus. Addresses for Read and Write addresses are latched on alternate rising edges of the input (K) clock. Accesses to the QDR-II Read and Write ports are completely independent of one another. In order to maximize data throughput, both Read and Write ports are equipped with Double Data Rate (DDR) interfaces. Each address location is associated with four 8-bit words (CY7C1311V18) or 18-bit words (CY7C1313V18) or 36-bit words (CY7C1315V18) that burst sequentially into or out of the device. Since data can be transferred into and out of the device on every rising edge of both input clocks (K/ \bar{K} and C/ \bar{C}), memory bandwidth is maximized while simplifying system design by eliminating bus “turn-arounds”.

Depth expansion is accomplished with Port Selects for each port. Port selects allow each port to operate independently.

All synchronous inputs pass through input registers controlled by the K or \bar{K} input clocks. All data outputs pass through output registers controlled by the C or \bar{C} input clocks. Writes are conducted with on-chip synchronous self-timed write circuitry.

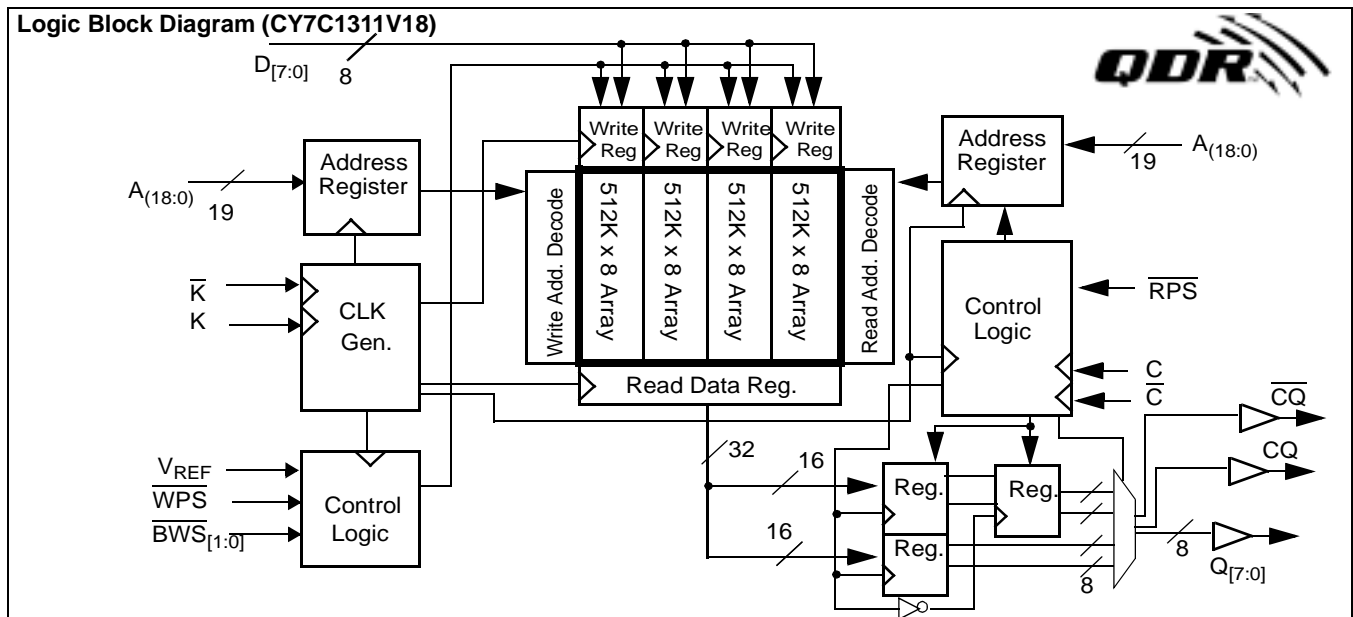



Pin Configurations

CY7C1311V18 (2M x 8)–11 x 15 FBGA

	1	2	3	4	5	6	7	8	9	10	11
A	CQ	V _{SS} /72M	A	WPS	BWS ₁	K	NC	RPS	A	V _{SS} /36M	CQ
B	NC	NC	NC	A	NC	K	$\overline{\text{BWS}}_0$	A	NC	NC	Q3
C	NC	NC	NC	V _{SS}	A	NC	A	V _{SS}	NC	NC	D3
D	NC	D4	NC	V _{SS}	V _{SS}	V _{SS}	V _{SS}	V _{SS}	NC	NC	NC
E	NC	NC	Q4	V _{DDQ}	V _{SS}	V _{SS}	V _{SS}	V _{DDQ}	NC	D2	Q2
F	NC	NC	NC	V _{DDQ}	V _{DD}	V _{SS}	V _{DD}	V _{DDQ}	NC	NC	NC
G	NC	D5	Q5	V _{DDQ}	V _{DD}	V _{SS}	V _{DD}	V _{DDQ}	NC	NC	NC
H	DOFF	V _{REF}	V _{DDQ}	V _{DDQ}	V _{DD}	V _{SS}	V _{DD}	V _{DDQ}	V _{DDQ}	V _{REF}	ZQ
J	NC	NC	NC	V _{DDQ}	V _{DD}	V _{SS}	V _{DD}	V _{DDQ}	NC	Q1	D1
K	NC	NC	NC	V _{DDQ}	V _{DD}	V _{SS}	V _{DD}	V _{DDQ}	NC	NC	NC
L	NC	Q6	D6	V _{DDQ}	V _{SS}	V _{SS}	V _{SS}	V _{DDQ}	NC	NC	Q0
M	NC	NC	NC	V _{SS}	V _{SS}	V _{SS}	V _{SS}	V _{SS}	NC	NC	D0
N	NC	D7	NC	V _{SS}	A	A	A	V _{SS}	NC	NC	NC
P	NC	NC	Q7	A	A	C	A	A	NC	NC	NC
R	TDO	TCK	A	A	A	$\overline{\text{C}}$	A	A	A	TMS	TDI

CY7C1313V18 (1M x 18)–11 x 15 FBGA

	1	2	3	4	5	6	7	8	9	10	11
A	CQ	V _{SS} /144M	NC/36M	WPS	BWS ₁	K	NC	RPS	A	V _{SS} /72M	CQ
B	NC	Q9	D9	A	NC	K	$\overline{\text{BWS}}_0$	A	NC	NC	Q8
C	NC	NC	D10	V _{SS}	A	NC	A	V _{SS}	NC	Q7	D8
D	NC	D11	Q10	V _{SS}	V _{SS}	V _{SS}	V _{SS}	V _{SS}	NC	NC	D7
E	NC	NC	Q11	V _{DDQ}	V _{SS}	V _{SS}	V _{SS}	V _{DDQ}	NC	D6	Q6
F	NC	Q12	D12	V _{DDQ}	V _{DD}	V _{SS}	V _{DD}	V _{DDQ}	NC	NC	Q5
G	NC	D13	Q13	V _{DDQ}	V _{DD}	V _{SS}	V _{DD}	V _{DDQ}	NC	NC	D5
H	DOFF	V _{REF}	V _{DDQ}	V _{DDQ}	V _{DD}	V _{SS}	V _{DD}	V _{DDQ}	V _{DDQ}	V _{REF}	ZQ
J	NC	NC	D14	V _{DDQ}	V _{DD}	V _{SS}	V _{DD}	V _{DDQ}	NC	Q4	D4
K	NC	NC	Q14	V _{DDQ}	V _{DD}	V _{SS}	V _{DD}	V _{DDQ}	NC	D3	Q3
L	NC	Q15	D15	V _{DDQ}	V _{SS}	V _{SS}	V _{SS}	V _{DDQ}	NC	NC	Q2
M	NC	NC	D16	V _{SS}	V _{SS}	V _{SS}	V _{SS}	V _{SS}	NC	Q1	D2
N	NC	D17	Q16	V _{SS}	A	A	A	V _{SS}	NC	NC	D1
P	NC	NC	Q17	A	A	C	A	A	NC	D0	Q0
R	TDO	TCK	A	A	A	$\overline{\text{C}}$	A	A	A	TMS	TDI



Pin Configurations (continued)

CY7C1315V18 (512K x 36)–11 x 15 FBGA

	1	2	3	4	5	6	7	8	9	10	11
A	CQ	V _{SS} /288M	NC/72M	WPS	BWS ₂	K	BWS ₁	RPS	NC/36M	V _{SS} /144M	CQ
B	Q27	Q18	D18	A	BWS ₃	K	BWS ₀	A	D17	Q17	Q8
C	D27	Q28	D19	V _{SS}	A	NC	A	V _{SS}	D16	Q7	D8
D	D28	D20	Q19	V _{SS}	V _{SS}	V _{SS}	V _{SS}	V _{SS}	Q16	D15	D7
E	Q29	D29	Q20	V _{DDQ}	V _{SS}	V _{SS}	V _{SS}	V _{DDQ}	Q15	D6	Q6
F	Q30	Q21	D21	V _{DDQ}	V _{DD}	V _{SS}	V _{DD}	V _{DDQ}	D14	Q14	Q5
G	D30	D22	Q22	V _{DDQ}	V _{DD}	V _{SS}	V _{DD}	V _{DDQ}	Q13	D13	D5
H	DOFF	V _{REF}	V _{DDQ}	V _{DDQ}	V _{DD}	V _{SS}	V _{DD}	V _{DDQ}	V _{DDQ}	V _{REF}	ZQ
J	D31	Q31	D23	V _{DDQ}	V _{DD}	V _{SS}	V _{DD}	V _{DDQ}	D12	Q4	D4
K	Q32	D32	Q23	V _{DDQ}	V _{DD}	V _{SS}	V _{DD}	V _{DDQ}	Q12	D3	Q3
L	Q33	Q24	D24	V _{DDQ}	V _{SS}	V _{SS}	V _{SS}	V _{DDQ}	D11	Q11	Q2
M	D33	Q34	D25	V _{SS}	V _{SS}	V _{SS}	V _{SS}	V _{SS}	D10	Q1	D2
N	D34	D26	Q25	V _{SS}	A	A	A	V _{SS}	Q10	D9	D1
P	Q35	D35	Q26	A	A	C	A	A	Q9	D0	Q0
R	TDO	TCK	A	A	A	C	A	A	A	TMS	TDI

Pin Definitions

Pin Name	I/O	Pin Description
D _[x:0]	Input-Synchronous	Data input signals, sampled on the rising edge of K and \bar{K} clocks during valid write operations. CY7C1311V18 – D _[7:0] CY7C1313V18 – D _[17:0] CY7C1315V18 – D _[35:0]
WPS	Input-Synchronous	Write Port Select, active LOW. Sampled on the rising edge of the K clock. When asserted active, a write operation is initiated. Deasserting will deselect the Write port. Deselecting the Write port will cause D _[x:0] to be ignored.
$\overline{BWS_0}$, $\overline{BWS_1}$, $\overline{BWS_2}$, $\overline{BWS_3}$	Input-Synchronous	Byte Write Select 0, 1, 2 and 3 – active LOW. Sampled on the rising edge of the K and \bar{K} clocks during write operations. Used to select which byte is written into the device during the current portion of the write operations. Bytes not written remain unaltered. CY7C1311V18 – $\overline{BWS_0}$ controls D _[3:0] and $\overline{BWS_1}$ controls D _[7:4] . CY7C1313V18 – $\overline{BWS_0}$ controls D _[8:0] and $\overline{BWS_1}$ controls D _[17:9] . CY7C1315V18 – $\overline{BWS_0}$ controls D _[8:0] , $\overline{BWS_1}$ controls D _[17:9] , $\overline{BWS_2}$ controls D _[26:18] and $\overline{BWS_3}$ controls D _[35:27] . All the byte writes are sampled on the same edge as the data. Deselecting a Byte Write Select will cause the corresponding byte of data to be ignored and not written into the device.
A	Input-Synchronous	Address Inputs. Sampled on the rising edge of the K clock during active read and write operations. These address inputs are multiplexed for both Read and Write operations. Internally, the device is organized as 2M x 8 (4 arrays each of 512K x 8) for CY7C1311V18, 1M x 18 (4 arrays each of 256K x 18) for CY7C1313V18 and 256K x 36 (4 arrays each of 128K x 36) for CY7C1315V18. Therefore, only 19 address inputs are needed to access the entire memory array of CY7C1311V18, 18 address inputs for CY7C1313V18 and 17 address inputs for CY7C1315V18. These inputs are ignored when the appropriate port is deselected.

Pin Definitions (continued)

Pin Name	I/O	Pin Description
Q _[x:0]	Outputs-Synchronous	Data Output signals. These pins drive out the requested data during a Read operation. Valid data is driven out on the rising edge of both the C and \bar{C} clocks during Read operations or K and \bar{K} , when in single clock mode. When the Read port is deselected, Q _[x:0] are automatically three-stated. CY7C1311V18 – Q _[7:0] CY7C1313V18 – Q _[17:0] CY7C1315V18 – Q _[35:0]
RPS	Input-Synchronous	Read Port Select, active LOW. Sampled on the rising edge of Positive Input Clock (K). When active, a Read operation is initiated. Deasserting will cause the Read port to be deselected. When deselected, the pending access is allowed to complete and the output drivers are automatically three-stated following the next rising edge of the C clock. Each read access consists of a burst of four sequential transfers.
C	Input-Clock	Positive Output Clock Input. C is used in conjunction with \bar{C} to clock out the Read data from the device. C and \bar{C} can be used together to deskew the flight times of various devices on the board back to the controller. See application example for further details.
\bar{C}	Input-Clock	Negative Output Clock Input. \bar{C} is used in conjunction with C to clock out the Read data from the device. C and \bar{C} can be used together to deskew the flight times of various devices on the board back to the controller. See application example for further details.
K	Input-Clock	Positive Input Clock Input. The rising edge of K is used to capture synchronous inputs to the device and to drive out data through Q _[x:0] when in single clock mode. All accesses are initiated on the rising edge of K.
\bar{K}	Input-Clock	Negative Input Clock Input. \bar{K} is used to capture synchronous inputs being presented to the device and to drive out data through Q _[x:0] when in single clock mode.
CQ	Echo Clock	CQ is referenced with respect to C. This is a free running clock and is synchronized to the output clock of the QDR-II. In the single clock mode, CQ is generated with respect to K. The timings for the echo clocks are shown in the AC timing table.
$\bar{C}Q$	Echo Clock	$\bar{C}Q$ is referenced with respect to \bar{C}. This is a free running clock and is synchronized to the output clock of the QDR-II. In the single clock mode, $\bar{C}Q$ is generated with respect to K. The timings for the echo clocks are shown in the AC timing table.
ZQ	Input	Output Impedance Matching Input. This input is used to tune the device outputs to the system data bus impedance. Q _[x:0] output impedance are set to 0.2 x RQ, where RQ is a resistor connected between ZQ and ground. Alternately, this pin can be connected directly to V _{DD} , which enables the minimum impedance mode. This pin cannot be connected directly to GND or left unconnected.
DOFF	Input	DLL Turn Off. Connecting this pin to ground will turn off the DLL inside the device. The timings in the DLL turned off operation will be different from those listed in this data sheet. More details on this operation can be found in the application note, "DLL Operation in the QDR-II."
TDO	Output	TDO for JTAG.
TCK	Input	TCK pin for JTAG.
TDI	Input	TDI pin for JTAG.
TMS	Input	TMS pin for JTAG.
NC	Input	No connects inside the package. Can be tied to any voltage level.
NC/36M	Input	Address expansion for 36M. This is not connected to the die and so can be tied to any voltage level.
NC/72M	Input	Address expansion for 72M. This is not connected to the die and so can be tied to any voltage level.
V _{SS} /72M	Input	Address expansion for 72M. This must be tied LOW on the these devices.
V _{SS} /144M	Input	Address expansion for 144M. This must be tied LOW on the these devices.
V _{SS} /288M	Input	Address expansion for 288M. This must be tied LOW on the these devices.



Pin Definitions (continued)

Pin Name	I/O	Pin Description
V _{REF}	Input-Reference	Reference Voltage Input. Static input used to set the reference level for HSTL inputs and Outputs as well as AC measurement points.
V _{DD}	Power Supply	Power supply inputs to the core of the device. Should be connected to 1.8V power supply.
V _{SS}	Ground	Ground for the device. Should be connected to ground of the system.
V _{DDQ}	Power Supply	Power supply inputs for the outputs of the device. Should be connected to 1.5V power supply.

Introduction

Functional Overview

The CY7C1311V18/CY7C1313V18/CY7C1315V18 are synchronous pipelined Burst SRAMs equipped with both a Read Port and a Write Port. The Read port is dedicated to Read operations and the Write Port is dedicated to Write operations. Data flows into the SRAM through the Write port and out through the Read Port. These devices multiplex the address inputs in order to minimize the number of address pins required. By having separate Read and Write ports, the QDR-II completely eliminates the need to “turn-around” the data bus and avoids any possible data contention, thereby simplifying system design. Each access consists of four 8-bit data transfers in the case of CY7C1311V18, four 18-bit data transfers in the case of CY7C1313V18, and four 36-bit data in the case of CY7C1315V18 transfers in two clock cycles.

Accesses for both ports are initiated on the Positive Input Clock (K). All synchronous input timing is referenced from the rising edge of the input clocks (K and \bar{K}) and all output timing is referenced to the output clocks (C and \bar{C} or K and \bar{K} when in single clock mode).

All synchronous data inputs (D_[x:0]) inputs pass through input registers controlled by the input clocks (K and \bar{K}). All synchronous data outputs (Q_[x:0]) outputs pass through output registers controlled by the rising edge of the output clocks (C and \bar{C} or K and \bar{K} when in single-clock mode).

All synchronous control (\overline{RPS} , \overline{WPS} , $\overline{BWS}_{[x:0]}$) inputs pass through input registers controlled by the rising edge of the input clocks (K and \bar{K}).

The following descriptions take CY7C1313V18 as an example. However, the same is true for the other QDR-II SRAMs, CY7C1311V18 and CY7C1315V18.

These chips utilize a Delay Lock Loop (DLL) that is designed to function between 80 MHz and the specified maximum clock frequency. The DLL may be disabled by applying ground to the DOFF pin.

Read Operations

The CY7C1313V18 is organized internally as a 256K x 72 SRAM. Accesses are completed in a burst of four sequential 18-bit data words. Read operations are initiated by asserting \overline{RPS} active at the rising edge of the Positive Input Clock (K). The address presented to Address inputs are stored in the Read address register. Following the next K clock rise, the corresponding lowest order 18-bit word of data is driven onto the Q_[17:0] using \bar{C} as the output timing reference. On the subsequent rising edge of C the next 18-bit data word is driven onto the Q_[17:0]. This process continues until all four 18-bit data words have been driven out onto Q_[17:0]. The requested data will be valid 0.35 ns from the rising edge of the output clock (C

or \bar{C} , 250-MHz device). In order to maintain the internal logic, each read access must be allowed to complete. Each Read access consists of four 18-bit data words and takes 2 clock cycles to complete. Therefore, Read accesses to the device can not be initiated on two consecutive K clock rises. The internal logic of the device will ignore the second Read request. Read accesses can be initiated on every other K clock rise. Doing so will pipeline the data flow such that data is transferred out of the device on every rising edge of the output clocks (C and \bar{C} or K and \bar{K} when in single-clock mode).

When the read port is deselected, the CY7C1313V18 will first complete the pending read transactions. Synchronous internal circuitry will automatically three-state the outputs following the next rising edge of the Positive Output Clock (C). This will allow for a seamless transition between devices without the insertion of wait states in a depth expanded memory.

Write Operations

Write operations are initiated by asserting \overline{WPS} active at the rising edge of the Positive Input Clock (K). On the following K clock rise the data presented to D_[17:0] is latched and stored into the lower 18-bit Write Data register, provided $\overline{BWS}_{[1:0]}$ are both asserted active. On the subsequent rising edge of the Negative Input Clock (\bar{K}) the information presented to D_[17:0] is also stored into the Write Data Register, provided $\overline{BWS}_{[1:0]}$ are both asserted active. This process continues for one more cycle until four 18-bit words (a total of 72 bits) of data are stored in the SRAM. The 72 bits of data are then written into the memory array at the specified location. Therefore, Write accesses to the device can not be initiated on two consecutive K clock rises. The internal logic of the device will ignore the second Write request. Write accesses can be initiated on every other rising edge of the Positive Input Clock (K). Doing so will pipeline the data flow such that 18 bits of data can be transferred into the device on every rising edge of the input clocks (K and \bar{K}).

When deselected, the write port will ignore all inputs after the pending Write operations have been completed.

Byte Write Operations

Byte Write operations are supported by the CY7C1313V18. A write operation is initiated as described in the Write Operation section above. The bytes that are written are determined by \overline{BWS}_0 and \overline{BWS}_1 , which are sampled with each set of 18-bit data words. Asserting the appropriate Byte Write Select input during the data portion of a write will allow the data being presented to be latched and written into the device. Deasserting the Byte Write Select input during the data portion of a write will allow the data stored in the device for that byte

to remain unaltered. This feature can be used to simplify Read/Modify/Write operations to a Byte Write operation.

Single Clock Mode

The CY7C1313V18 can be used with a single clock that controls both the input and output registers. In this mode the device will recognize only a single pair of input clocks (K and \overline{K}) that control both the input and output registers. This operation is identical to the operation if the device had zero skew between the $\overline{K/K}$ and C/C clocks. All timing parameters remain the same in this mode. To use this mode of operation, the user must tie C and \overline{C} HIGH at power on. This function is a strap option and not alterable during device operation.

Concurrent Transactions

The Read and Write ports on the CY7C1313V18 operate completely independently of one another. Since each port latches the address inputs on different clock edges, the user can Read or Write to any location, regardless of the transaction on the other port. If the ports access the same location when a read follows a write in successive clock cycles, the SRAM will deliver the most recent information associated with the specified address location. This includes forwarding data from a Write cycle that was initiated on the previous K clock rise.

Read accesses and Write access must be scheduled such that one transaction is initiated on any clock cycle. If both ports are selected on the same K clock rise, the arbitration depends on the previous state of the SRAM. If both ports were deselected, the Read port will take priority. If a Read was initiated on the previous cycle, the Write port will assume priority (since Read operations can not be initiated on consecutive cycles). If a Write was initiated on the previous cycle, the Read port will assume priority (since Write operations can not be initiated on

consecutive cycles). Therefore, asserting both port selects active from a deselected state will result in alternating Read/Write operations being initiated, with the first access being a Read.

Depth Expansion

The CY7C1313V18 has a Port Select input for each port. This allows for easy depth expansion. Both Port Selects are sampled on the rising edge of the Positive Input Clock only (K). Each port select input can deselect the specified port. Deselecting a port will not affect the other port. All pending transactions (Read and Write) will be completed prior to the device being deselected.

Programmable Impedance

An external resistor, R_Q , must be connected between the ZQ pin on the SRAM and V_{SS} to allow the SRAM to adjust its output driver impedance. The value of R_Q must be 5X the value of the intended line impedance driven by the SRAM, The allowable range of R_Q to guarantee impedance matching with a tolerance of $\pm 10\%$ is between 175Ω and 350Ω , with $V_{DDQ} = 1.5V$. The output impedance is adjusted every 1024 cycles to adjust for drifts in supply voltage and temperature.

Echo Clocks

Echo clocks are provided on the QDR-II to simplify data capture on high speed systems. Two echo clocks are generated by the QDR-II. CQ is referenced with respect to C and \overline{CQ} is referenced with respect to \overline{C} . These are free running clocks and are synchronized to the output clock of the QDR-II. In the single clock mode, CQ is generated with respect to K and \overline{CQ} is generated with respect to \overline{K} . The timings for the echo clocks are shown in the AC timing table.

Application Example^[2]

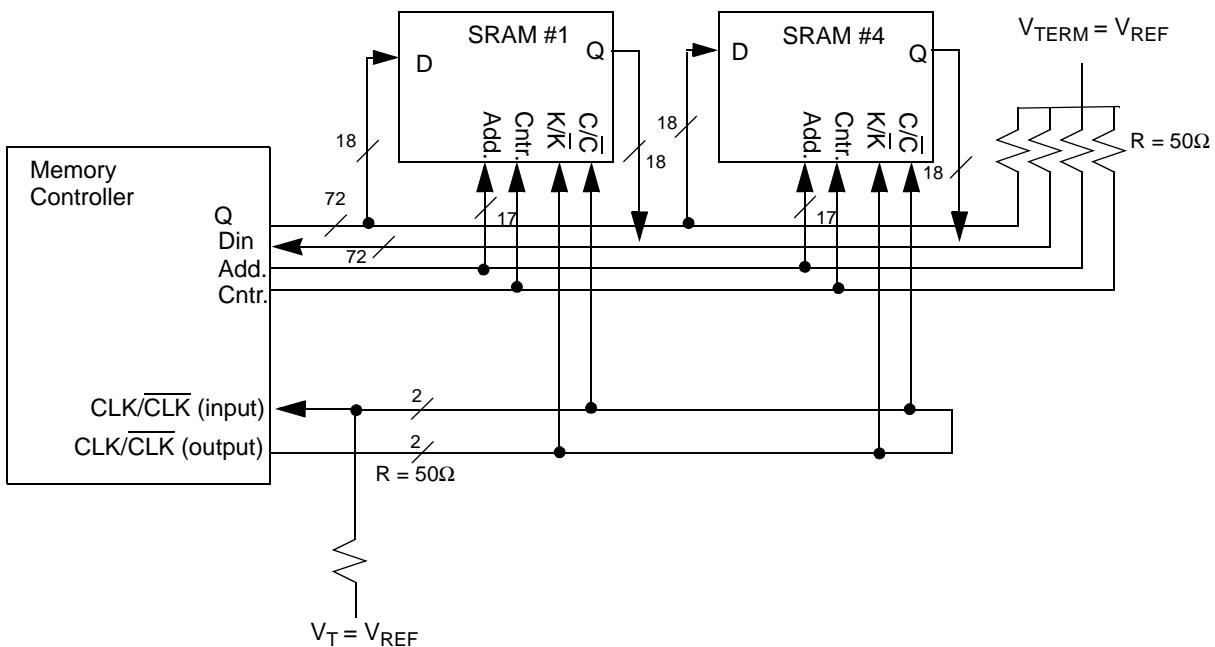

Note:

- The above application shows four CY7C1313V18s being used. This holds true for CY7C1311V18 and CY7C1315V18 as well.

Truth Table [3, 4, 5, 6, 7, 8]

Operation	K	RPS	WPS	DQ	DQ	DQ	DQ
Write Cycle: Load address on the rising edge of K; input write data on two consecutive K and \bar{K} rising edges.	L-H	H ^[9]	L ^[10]	D(A + 00) at K(t + 1) ↑	D(A + 01) at $\bar{K}(t + 1)$ ↑	D(A + 10) at K(t + 2) ↑	D(A + 11) at $\bar{K}(t + 2)$ ↑
Read Cycle: Load address on the rising edge of K; wait one and a half cycle; read data on two consecutive C and \bar{C} rising edges.	L-H	L ^[10]	X	Q(A + 00) at C(t + 1) ↑	Q(A + 01) at C(t + 2) ↑	Q(A + 10) at $\bar{C}(t + 2)$ ↑	Q(A + 11) at C(t + 3) ↑
NOP: No Operation	L-H	H	H	High-Z	High-Z	High-Z	High-Z
Standby: Clock Stopped	Stopped	X	X	Previous State	Previous State	Previous State	Previous State

Write Cycle Descriptions CY7C1311V18 and CY7C1313V18 [3, 11]

BWS ₀	BWS ₁	K	\bar{K}	Comments
L	L	L-H	-	During the Data portion of a Write sequence : CY7C1311V18 – both nibbles (D _[7:0]) are written into the device, CY7C1313V18 – both bytes (D _[17:0]) are written into the device.
L	L	-	L-H	During the Data portion of a Write sequence : CY7C1311V18 – both nibbles (D _[7:0]) are written into the device, CY7C1313V18 – both bytes (D _[17:0]) are written into the device.
L	H	L-H	-	During the Data portion of a Write sequence : CY7C1311V18 – only the lower nibble (D _[3:0]) is written into the device. D _[7:4] will remain unaltered, CY7C1313V18 – only the lower byte (D _[8:0]) is written into the device. D _[17:9] will remain unaltered.
L	H	-	L-H	During the Data portion of a Write sequence : CY7C1311V18 – only the lower nibble (D _[3:0]) is written into the device. D _[7:4] will remain unaltered, CY7C1313V18 – only the lower byte (D _[8:0]) is written into the device. D _[17:9] will remain unaltered.
H	L	L-H	-	During the Data portion of a Write sequence : CY7C1311V18 – only the upper nibble (D _[7:4]) is written into the device. D _[3:0] will remain unaltered, CY7C1313V18 – only the upper byte (D _[17:9]) is written into the device. D _[8:0] will remain unaltered.
H	L	-	L-H	During the Data portion of a Write sequence : CY7C1311V18 – only the upper nibble (D _[7:4]) is written into the device. D _[3:0] will remain unaltered, CY7C1313V18 – only the upper byte (D _[17:9]) is written into the device. D _[8:0] will remain unaltered.
H	H	L-H	-	No data is written into the devices during this portion of a write operation.
H	H	-	L-H	No data is written into the devices during this portion of a write operation.

Notes:

- X = "Don't Care," H = Logic HIGH, L = Logic LOW, ↑ represents rising edge.
- Device will power-up deselected and the outputs in a three-state condition.
- "A" represents address location latched by the devices when transaction was initiated. A + 00, A + 01, A + 10, and A + 11 represents the address sequence in the burst.
- "t" represents the cycle at which a read/write operation is started. t + 1, t + 2, and t + 3 are the first, second and third clock cycles respectively succeeding the "t" clock cycle.
- Data inputs are registered at K and \bar{K} rising edges. Data outputs are delivered on C and \bar{C} rising edges, except when in single clock mode.
- It is recommended that K = \bar{K} and C = \bar{C} = HIGH when clock is stopped. This is not essential, but permits most rapid restart by overcoming transmission line charging symmetrically.
- If this signal was LOW to initiate the previous cycle, this signal becomes a "Don't Care" for this operation.
- This signal was HIGH on previous K clock rise. Initiating consecutive Read or Write operations on consecutive K clock rises is not permitted. The device will ignore the second Read or Write request.
- Assumes a Write cycle was initiated per the Write Port Cycle Description Truth Table. BWS₀, BWS₁ in the case of CY7C1311V18 and CY7C1313V18 and also BWS₂, BWS₃ in the case of CY7C1315V18 can be altered on different portions of a write cycle, as long as the set-up and hold requirements are achieved.



Write Cycle Descriptions^[3, 11](CY7C1315V18)

$\overline{\text{BWS}}_0$	$\overline{\text{BWS}}_1$	$\overline{\text{BWS}}_2$	$\overline{\text{BWS}}_3$	K	$\overline{\text{K}}$	Comments
L	L	L	L	L-H	-	During the Data portion of a Write sequence, all four bytes ($D_{[35:0]}$) are written into the device.
L	L	L	L	-	L-H	During the Data portion of a Write sequence, all four bytes ($D_{[35:0]}$) are written into the device.
L	H	H	H	L-H	-	During the Data portion of a Write sequence, only the lower byte ($D_{[8:0]}$) is written into the device. $D_{[35:9]}$ will remain unaltered.
L	H	H	H	-	L-H	During the Data portion of a Write sequence, only the lower byte ($D_{[8:0]}$) is written into the device. $D_{[35:9]}$ will remain unaltered.
H	L	H	H	L-H	-	During the Data portion of a Write sequence, only the byte ($D_{[17:9]}$) is written into the device. $D_{[8:0]}$ and $D_{[35:18]}$ will remain unaltered.
H	L	H	H	-	L-H	During the Data portion of a Write sequence, only the byte ($D_{[17:9]}$) is written into the device. $D_{[8:0]}$ and $D_{[35:18]}$ will remain unaltered.
H	H	L	H	L-H	-	During the Data portion of a Write sequence, only the byte ($D_{[26:18]}$) is written into the device. $D_{[17:0]}$ and $D_{[35:27]}$ will remain unaltered.
H	H	L	H	-	L-H	During the Data portion of a Write sequence, only the byte ($D_{[26:18]}$) is written into the device. $D_{[17:0]}$ and $D_{[35:27]}$ will remain unaltered.
H	H	H	L	L-H	-	During the Data portion of a Write sequence, only the byte ($D_{[35:27]}$) is written into the device. $D_{[26:0]}$ will remain unaltered.
H	H	H	L	-	L-H	During the Data portion of a Write sequence, only the byte ($D_{[35:27]}$) is written into the device. $D_{[26:0]}$ will remain unaltered.
H	H	H	H	L-H	-	No data is written into the device during this portion of a write operation.
H	H	H	H	-	L-H	No data is written into the device during this portion of a write operation.



Maximum Ratings

(Above which the useful life may be impaired. For user guidelines, not tested.)

- Storage Temperature -65°C to +150°C
- Ambient Temperature with Power Applied..... -55°C to +125°C
- Supply Voltage on V_{DD} Relative to GND..... -0.5V to +2.9V
- DC Voltage Applied to Outputs in High-Z State^[14] -0.5V to V_{DDQ} + 0.5V
- DC Input Voltage^[14] -0.5V to V_{DDQ} + 0.5V

- Current into Outputs (LOW)..... 20 mA
- Static Discharge Voltage..... >2001V (per MIL-STD-883, Method 3015)
- Latch-up Current..... >200 mA

Operating Range

Range	Ambient Temperature ^[12]	V _{DD}	V _{DDQ}
Com'l	0°C to +70°C	1.8 ± 100 mV	1.4V to V _{DD}

Electrical Characteristics Over the Operating Range^[1, 13]

Parameter	Description	Test Conditions	Min.	Typ.	Max.	Unit
V _{DD}	Power Supply Voltage		1.7	1.8	1.9	V
V _{DDQ}	I/O Supply Voltage		1.4	1.5	V _{DD}	V
V _{OH}	Output HIGH Voltage	I _{OH} = -2.0 mA, Nominal Impedance	V _{DDQ} - 0.2	V _{DDQ} - 0.2	V _{DDQ}	V
V _{OL}	Output LOW Voltage	I _{OL} = 2.0 mA, Nominal Impedance	V _{SS}	V _{SS}	0.2	V
V _{IH}	Input HIGH Voltage ^[14]		V _{REF} + 0.1	V _{DDQ} +0.1	V _{DDQ} +0.3	V
V _{IL}	Input LOW Voltage ^[14]		-0.3	V _{REF} -0.1	V _{REF} -0.1	V
I _X	Input Load Current	GND ≤ V _I ≤ V _{DDQ}	-5	-5	5	μA
I _{OZ}	Output Leakage Current	GND ≤ V _I ≤ V _{DDQ} , Output Disabled	-5	-5	5	μA
V _{REF}	Input Reference Voltage ^[15]	Typical Value = 0.75V	0.68	0.75	0.95	V
I _{DD}	V _{DD} Operating Supply x8, x18	V _{DD} = Max., I _{OUT} = 0 mA, f = f _{MAX} = 1/t _{CYC}	167 MHz		TBD	mA
			200 MHz		TBD	mA
			250 MHz		TBD	mA
			300 MHz		TBD	mA
I _{DD}	V _{DD} Operating Supply x36	V _{DD} = Max., I _{OUT} = 0 mA, f = f _{MAX} = 1/t _{CYC}	167 MHz		TBD	mA
			200 MHz		TBD	mA
			250 MHz		TBD	mA
			300 MHz		TBD	mA
I _{SB1}	Automatic Power-down Current, x8, x18	Max. V _{DD} , Both Ports Deselected, V _{IN} ≥ V _{IH} or V _{IN} ≤ V _{IL} f = f _{MAX} = 1/t _{CYC} , Inputs Static	167 MHz		TBD	mA
			200 MHz		TBD	mA
			250 MHz		TBD	mA
			300 MHz		TBD	mA
I _{SB1}	Automatic Power-down Current, x36	Max. V _{DD} , Both Ports Deselected, V _{IN} ≥ V _{IH} or V _{IN} ≤ V _{IL} f = f _{MAX} = 1/t _{CYC} , Inputs Static	167 MHz		TBD	mA
			200 MHz		TBD	mA
			250 MHz		TBD	mA
			300 MHz		TBD	mA

Notes:

- 12. Ambient Temperature = T_A. This is the case temperature.
- 13. All Voltage referenced to Ground.
- 14. Overshoot: V_{IH}(AC) ≤ V_{DD} + 0.5V for t ≤ t_{CYC}/2; undershoot V_{IL}(AC) ≤ -0.5V for t ≤ t_{CYC}/2; power-up: V_{IH} < 1.8V and V_{DD} < 1.8V and V_{DDQ} < 1.4V for t < 200 ms.
- 15. V_{REF} Min. = 0.68V or 0.46V_{DDQ}, whichever is larger, V_{REF} Max. = 0.95V or 0.54V_{DDQ}, whichever is smaller.



Switching Characteristics Over the Operating Range^[1, 16]

Parameter	Description	300 MHz		250 MHz		200 MHz		167 MHz		Unit
		Min.	Max.	Min.	Max.	Min.	Max.	Min.	Max.	
t _{CYC}	K Clock and C Clock Cycle Time	3.3	4.0	4.0	5.0	5.0	6.0	6.0	7.5	ns
t _{KH}	Input Clock (K/K and C/C) HIGH	1.32	–	1.6	–	2.0	–	2.4	–	ns
t _{KL}	Input Clock (K/K and C/C) LOW	1.32	–	1.6	–	2.0	–	2.4	–	ns
t _{KHKH}	K/K Clock Rise to K/K Clock Rise and C/C to C/C Rise (rising edge to rising edge)	1.49	1.82	1.8	–	2.2	–	2.7	–	ns
t _{KHCH}	K/K Clock Rise to C/C Clock Rise (rising edge to rising edge)	0.0	1.45	0.0	1.8	0.0	2.3	0.0	2.8	ns
Set-up Times										
t _{SA}	Address Set-up to K Clock Rise	0.4	–	0.5	–	0.6	–	0.7	–	ns
t _{SC}	Control Set-up to Clock (K, K, C, C) Rise (RPS, WPS, BWS ₀ , BWS ₁ , BWS ₂ , BWS ₃)	0.4	–	0.5	–	0.6	–	0.7	–	ns
t _{SD}	D _[17:0] Set-up to Clock (K and K) Rise	0.3	–	0.4	–	0.5	–	0.6	–	ns
Hold Times										
t _{HA}	Address Hold after Clock (K and K) Rise	0.4	–	0.5	–	0.6	–	0.7	–	ns
t _{HC}	Control Hold after Clock (K and K) Rise (RPS, WPS, BWS ₀ , BWS ₁ , BWS ₂ , BWS ₃)	0.4	–	0.5	–	0.6	–	0.7	–	ns
t _{HD}	D _[17:0] Hold after Clock (K and K) Rise	0.3	–	0.4	–	0.5	–	0.6	–	ns
Output Times										
t _{CO}	C/C Clock Rise (or K/K in single clock mode) to Data Valid ^[16]	–	0.29	–	0.35	–	0.38	–	0.40	ns
t _{DOH}	Data Output Hold after Output C/C Clock Rise (Active to Active)	–0.29	–	–0.35	–	–0.38	–	–0.40	–	ns
t _{CCQO}	C/C Clock Rise to Echo Clock Valid		0.27		0.33		0.36		0.38	ns
t _{CQOH}	Echo Clock Hold after C/C Clock Rise	–0.27		–0.33		–0.36		–0.38		
t _{CQD}	Echo Clock High to Data Change	–0.27	0.29	–0.33	0.35	–0.36	0.38	–0.38	0.40	
t _{CLZ}	Clock (C and C) Rise to Low-Z ^[17, 18]	–0.29	–	–0.35	–	–0.38	–	–0.40	–	ns
t _{CHZ}	Clock (C and C) Rise to High-Z (Active to High-Z) ^[17, 18]	–	0.29	–	0.35	–	0.38	–	0.40	ns
DLL Timing										
t _{KC}	Clock Phase Jitter	–	0.08	–	0.10	–	0.13	–	0.15	ns
t _{KC lock}	DLL Lock Time (K, C)	1024	–	1024	–	1024	–	1024	–	cycles

Capacitance^[19]

Parameter	Description	Test Conditions	Max.	Unit
C _{IN}	Input Capacitance	T _A = 25°C, f = 1 MHz, V _{DD} = 1.8V V _{DDQ} = 1.5V	TBD	pF
C _{CLK}	Clock Input Capacitance		TBD	pF
C _O	Output Capacitance		TBD	pF

Notes:

16. Unless otherwise noted, test conditions assume signal transition time of 2V/ns, timing reference levels of 0.75V, V_{ref} = 0.75V, R_Q = 250Ω, V_{DDQ} = 1.5V, input pulse levels of 0.25V to 1.25V, and output loading of the specified I_{OL}/I_{OH} and load capacitance shown in (a) of AC test loads.
17. t_{CHZ}, t_{CLZ}, are specified with a load capacitance of 5 pF as in part (b) of AC Test Loads. Transition is measured ± 100 mV from steady-state voltage.
18. At any given voltage and temperature t_{CHZ} is less than t_{CLZ} and t_{CHZ} less than t_{CO}.

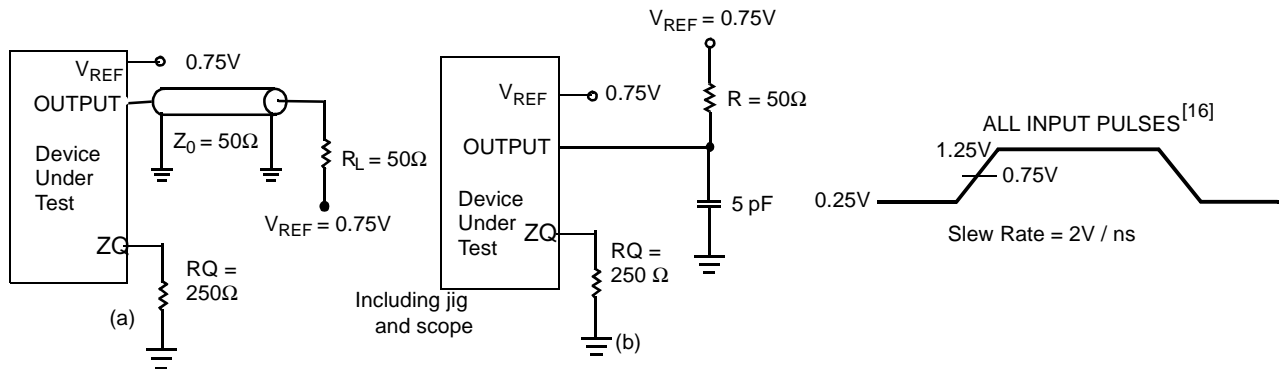
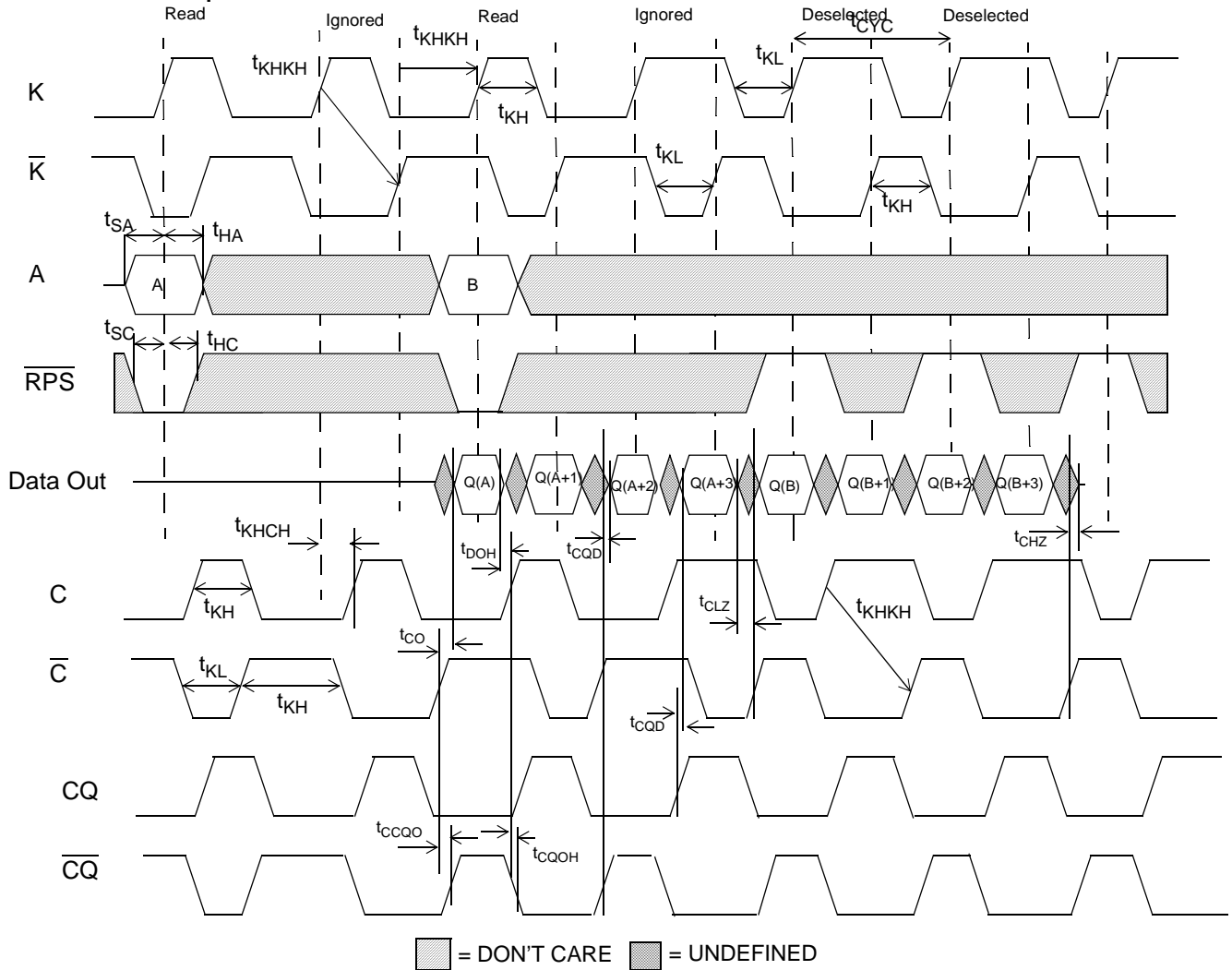
AC Test Loads and Waveforms

Switching Waveforms
Read/Deselect Sequence

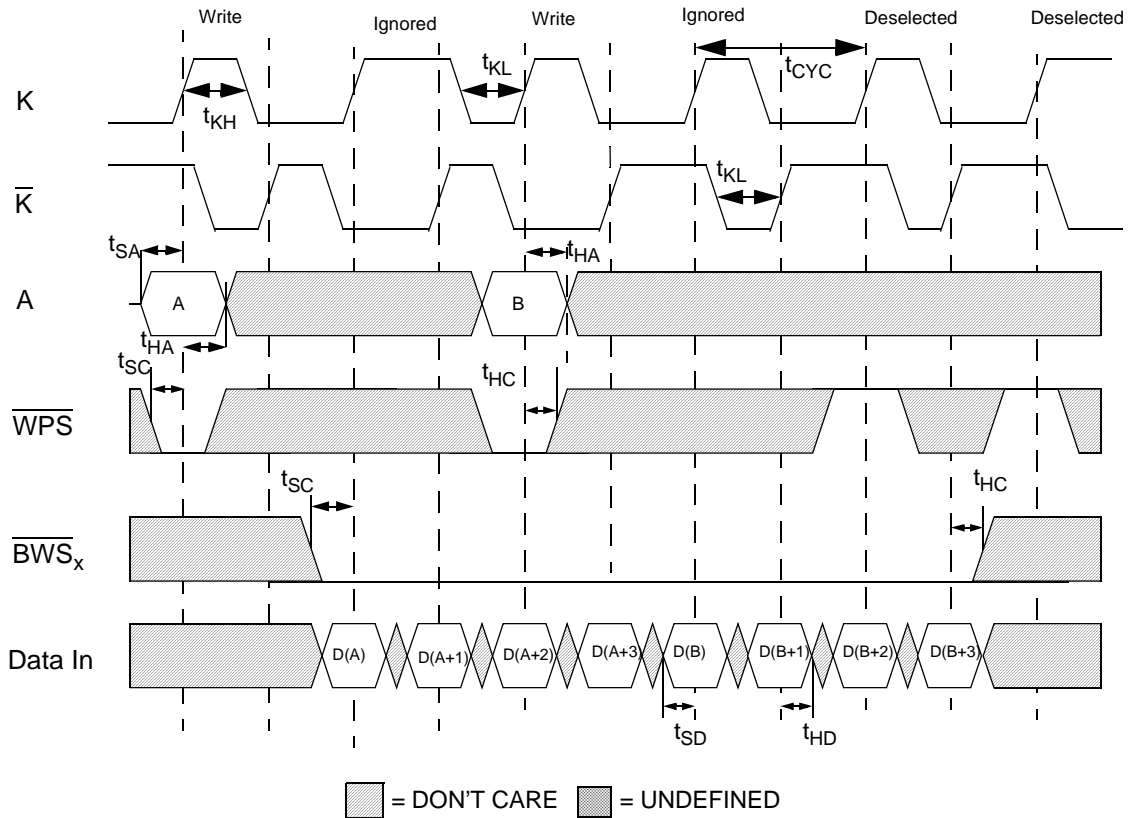
Note:

19. Tested initially and after any design or process change that may affect these parameters.

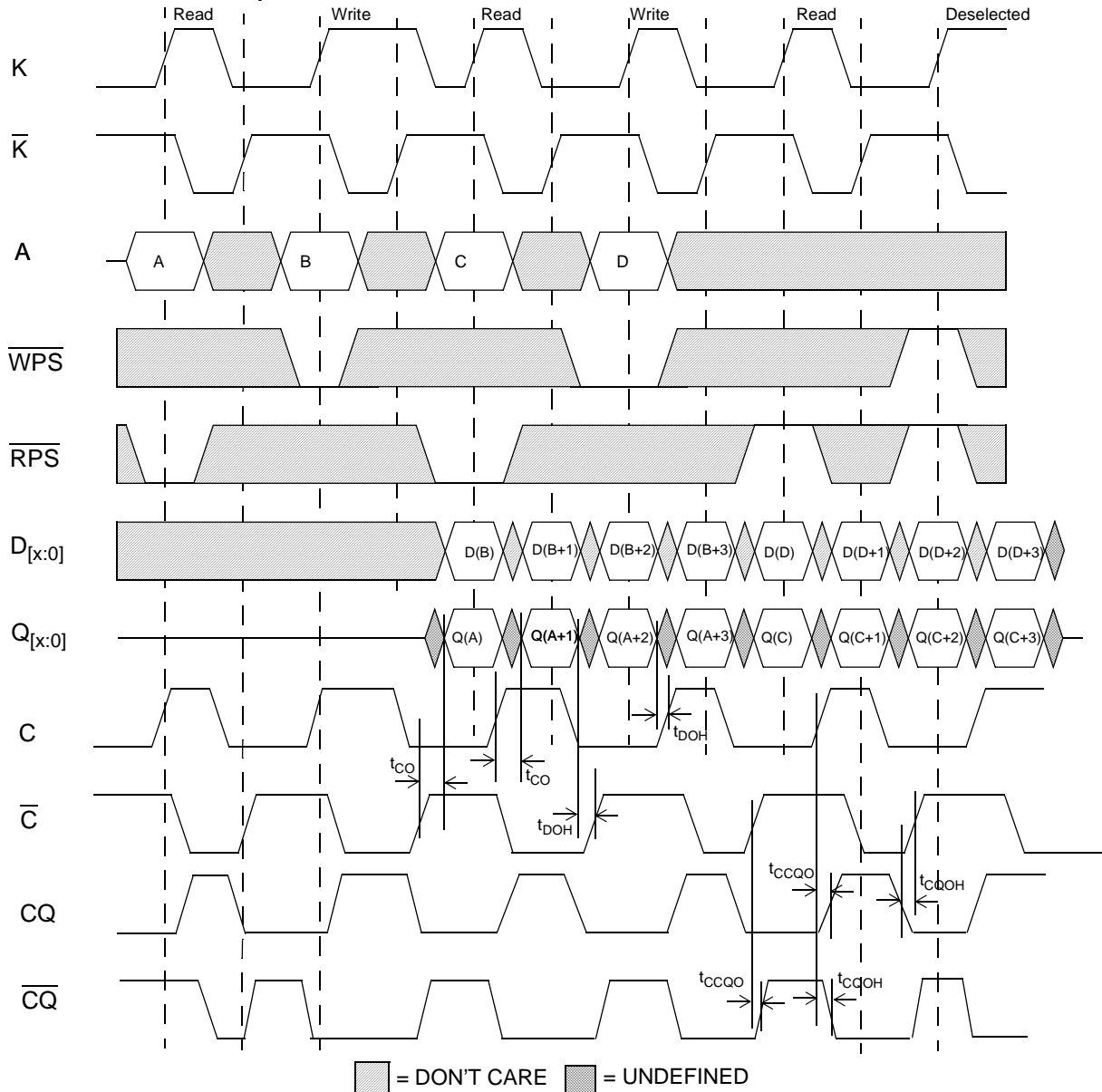
Switching Waveforms
Write/Deselect Sequence^[20, 21]

Notes:

- 20. \underline{C} and \bar{C} reference to Data Outputs and do not affect Write operations.
- 21. \overline{BWS}_x LOW=Valid, Byte writes allowed, see Byte write table for details.

Switching Waveforms
Read/Write/Deselect Sequence [22, 23]

Notes:

- 22. Read Port previously deselected.
- 23. BWS_x assumed active.

IEEE 1149.1 Serial Boundary Scan (JTAG)

The QDR-II incorporates a serial boundary scan test access port (TAP) in the FBGA package. This port operates in accordance with IEEE Standard 1149.1-1900, but does not have the set of functions required for full 1149.1 compliance. These functions from the IEEE specification are excluded because their inclusion places an added delay in the critical speed path of the SRAM. Note that the TAP controller functions in a manner that does not conflict with the operation of other devices using 1149.1 fully compliant TAPs. The TAP operates using JEDEC standard 1.8V I/O logic levels.

Disabling the JTAG Feature

It is possible to operate the SRAM without using the JTAG feature. To disable the TAP controller, TCK must be tied LOW (V_{SS}) to prevent clocking of the device. TDI and TMS are internally pulled up and may be unconnected. They may alternately be connected to V_{DD} through a pull-up resistor. TDO should be left unconnected. Upon power-up, the device will come up in a reset state which will not interfere with the operation of the device.

Test Access Port—Test Clock

The test clock is used only with the TAP controller. All inputs are captured on the rising edge of TCK. All outputs are driven from the falling edge of TCK.

Test Mode Select

The TMS input is used to give commands to the TAP controller and is sampled on the rising edge of TCK. It is allowable to leave this pin unconnected if the TAP is not used. The pin is pulled up internally, resulting in a logic HIGH level.

Test Data-in (TDI)

The TDI pin is used to serially input information into the registers and can be connected to the input of any of the registers. The register between TDI and TDO is chosen by the instruction that is loaded into the TAP instruction register. For information on loading the instruction register, see the TAP Controller State Diagram. TDI is internally pulled up and can be unconnected if the TAP is unused in an application. TDI is connected to the most significant bit (MSB) on any register.

Test Data-out (TDO)

The TDO output pin is used to serially clock data-out from the registers. The output is active depending upon the current state of the TAP state machine (see Instruction codes). The output changes on the falling edge of TCK. TDO is connected to the least significant bit (LSB) of any register.

Performing a TAP Reset

A Reset is performed by forcing TMS HIGH (V_{DD}) for five rising edges of TCK. This RESET does not affect the operation of the SRAM and may be performed while the SRAM is operating. At power-up, the TAP is reset internally to ensure that TDO comes up in a high-Z state.

TAP Registers

Registers are connected between the TDI and TDO pins and allow data to be scanned into and out of the SRAM test circuitry. Only one register can be selected at a time through the instruction registers. Data is serially loaded into the TDI pin

on the rising edge of TCK. Data is output on the TDO pin on the falling edge of TCK.

Instruction Register

Three-bit instructions can be serially loaded into the instruction register. This register is loaded when it is placed between the TDI and TDO pins as shown in TAP Controller Block Diagram. Upon power-up, the instruction register is loaded with the IDCODE instruction. It is also loaded with the IDCODE instruction if the controller is placed in a reset state as described in the previous section.

When the TAP controller is in the Capture IR state, the two least significant bits are loaded with a binary "01" pattern to allow for fault isolation of the board level serial test path.

Bypass Register

To save time when serially shifting data through registers, it is sometimes advantageous to skip certain chips. The bypass register is a single-bit register that can be placed between TDI and TDO pins. This allows data to be shifted through the SRAM with minimal delay. The bypass register is set LOW (V_{SS}) when the BYPASS instruction is executed.

Boundary Scan Register

The boundary scan register is connected to all the input and output pins on the SRAM. Several no connect (NC) pins are also included in the scan register to reserve pins for higher density devices.

The boundary scan register is loaded with the contents of the RAM Input and Output ring when the TAP controller is in the Capture-DR state and is then placed between the TDI and TDO pins when the controller is moved to the Shift-DR state. The EXTEST, SAMPLE/PRELOAD and SAMPLE Z instructions can be used to capture the contents of the Input and Output ring.

The Boundary Scan Order tables show the order in which the bits are connected. Each bit corresponds to one of the bumps on the SRAM package. The MSB of the register is connected to TDI, and the LSB is connected to TDO.

Identification (ID) Register

The ID register is loaded with a vendor-specific, 32-bit code during the Capture-DR state when the IDCODE command is loaded in the instruction register. The IDCODE is hardwired into the SRAM and can be shifted out when the TAP controller is in the Shift-DR state. The ID register has a vendor code and other information described in the Identification Register Definitions table.

TAP Instruction Set

Eight different instructions are possible with the three-bit instruction register. All combinations are listed in the Instruction Code table. Three of these instructions are listed as RESERVED and should not be used. The other five instructions are described in detail below.

The TAP controller used in this SRAM is not fully compliant to the 1149.1 convention because some of the mandatory 1149.1 instructions are not fully implemented. The TAP controller cannot be used to load address, data or control signals into the SRAM and cannot preload the Input or Output buffers. The



SRAM does not implement the 1149.1 commands EXTEST or INTEST or the PRELOAD portion of SAMPLE/PRELOAD; rather it performs a capture of the Input and Output ring when these instructions are executed.

Instructions are loaded into the TAP controller during the Shift-IR state when the instruction register is placed between TDI and TDO. During this state, instructions are shifted through the instruction register through the TDI and TDO pins. To execute the instruction once it is shifted in, the TAP controller needs to be moved into the Update-IR state.

EXTEST

EXTEST is a mandatory 1149.1 instruction which is to be executed whenever the instruction register is loaded with all 0s. EXTEST is not implemented in the TAP controller, and therefore this device is not compliant to the 1149.1 standard.

The TAP controller does not recognize an all-0 instruction. When an EXTEST instruction is loaded into the instruction register, the SRAM responds as if a SAMPLE/PRELOAD instruction has been loaded.

IDCODE

The IDCODE instruction causes a vendor-specific, 32-bit code to be loaded into the instruction register. It also places the instruction register between the TDI and TDO pins and allows the IDCODE to be shifted out of the device when the TAP controller enters the Shift-DR state. The IDCODE instruction is loaded into the instruction register upon power-up or whenever the TAP controller is given a test logic reset state.

SAMPLE Z

The SAMPLE Z instruction causes the boundary scan register to be connected between the TDI and TDO pins when the TAP controller is in a Shift-DR state.

SAMPLE/PRELOAD

SAMPLE/PRELOAD is a 1149.1 mandatory instruction. The PRELOAD portion of this instruction is not implemented, so the TAP controller is not fully 1149.1 compliant.

When the SAMPLE/PRELOAD instruction is loaded into the instruction register and the TAP controller is in the Capture-DR

state, a snapshot of data on the input and output pins is captured in the boundary scan register.

The user must be aware that the TAP controller clock can only operate at a frequency up to 10 MHz, while the SRAM clock operates more than an order of magnitude faster. Because there is a large difference in the clock frequencies, it is possible that during the Capture-DR state, an input or output will undergo a transition. The TAP may then try to capture a signal while in transition (metastable state). This will not harm the device, but there is no guarantee as to the value that will be captured. Repeatable results may not be possible.

To guarantee that the boundary scan register will capture the correct value of a signal, the SRAM signal must be stabilized long enough to meet the TAP controller's capture setup plus hold times (t_{CS} and t_{CH}). The SRAM clock inputs might not be captured correctly if there is no way in a design to stop (or slow) the clock during a SAMPLE/PRELOAD instruction. If this is an issue, it is still possible to capture all other signals and simply ignore the value of the K, K, C, and \bar{C} captured in the boundary scan register.

Once the data is captured, it is possible to shift out the data by putting the TAP into the Shift-DR state. This places the boundary scan register between the TDI and TDO pins.

Note that since the PRELOAD part of the command is not implemented, putting the TAP into the Update to the Update-DR state while performing a SAMPLE/PRELOAD instruction will have the same effect as the Pause-DR command.

Bypass

When the BYPASS instruction is loaded in the instruction register and the TAP is placed in a Shift-DR state, the bypass register is placed between the TDI and TDO pins. The advantage of the BYPASS instruction is that it shortens the boundary scan path when multiple devices are connected together on a board.

Reserved

These instructions are not implemented but are reserved for future use. Do not use these instructions.

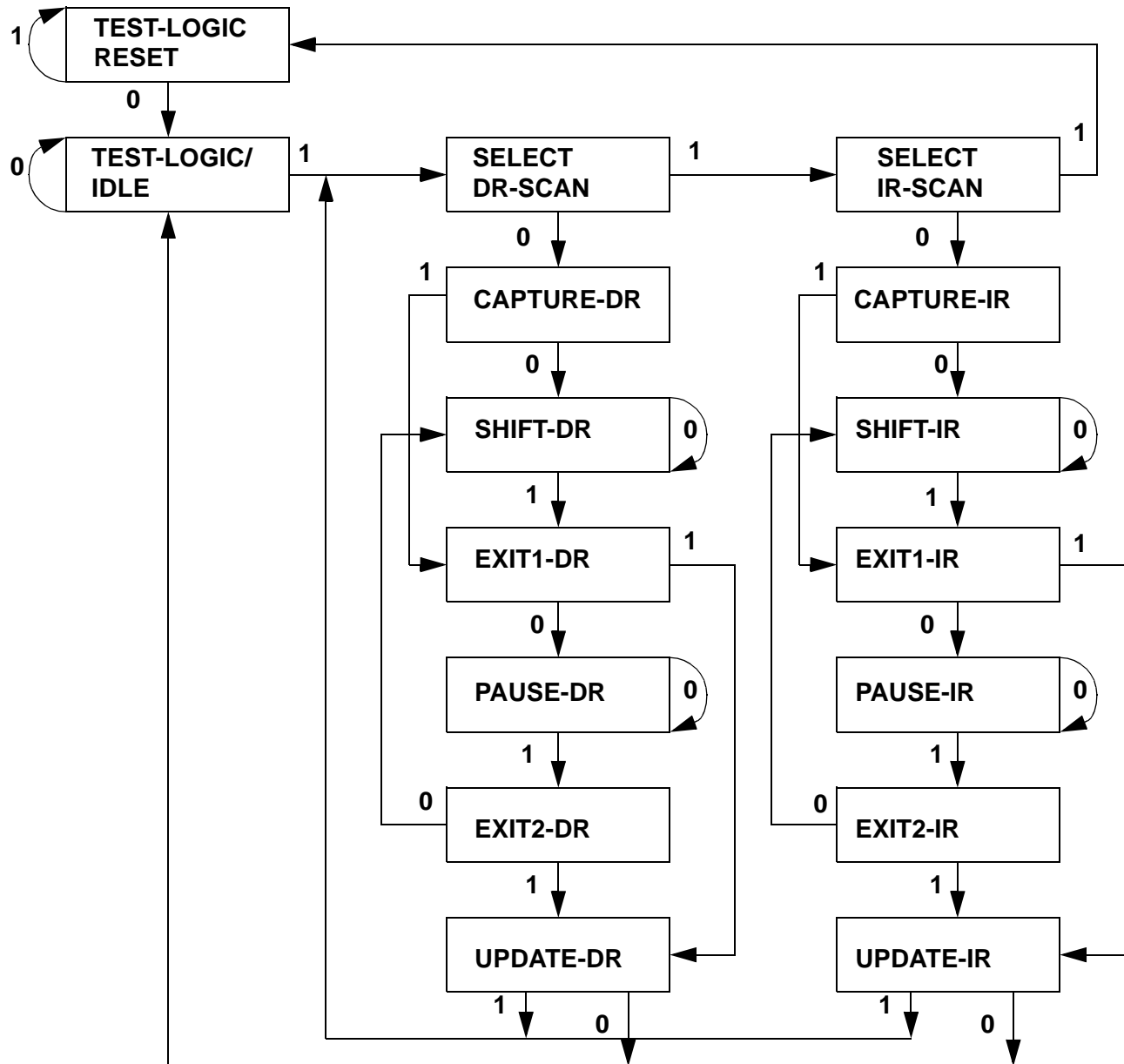
TAP Controller State Diagram^[24]

Note:
24. The 0/1 next to each state represents the value at TMS at the rising edge of TCK.

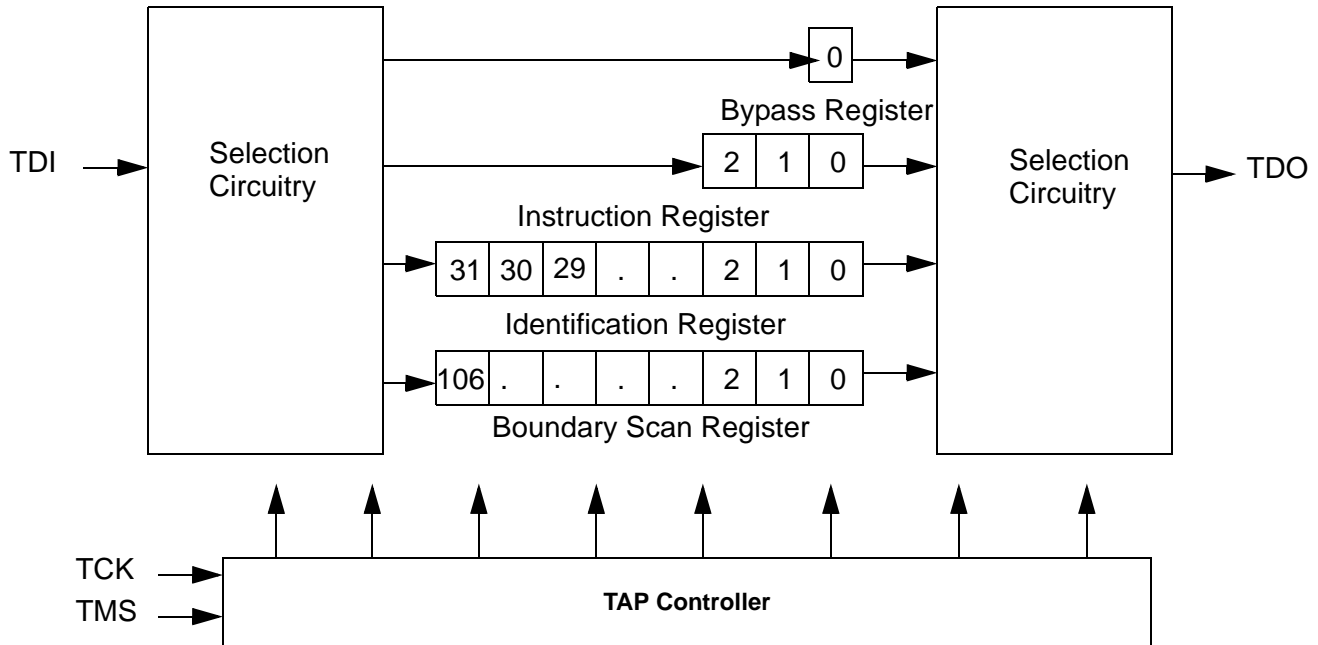
TAP Controller Block Diagram

TAP Electrical Characteristics Over the Operating Range^[25, 13, 14]

Parameter	Description	Test Conditions	Min.	Max.	Unit
V _{OH1}	Output HIGH Voltage	I _{OH} = -2.0 mA	V _{DD} - 0.45		V
V _{OH2}	Output HIGH Voltage	I _{OH} = -100 μA	V _D - 0.2		V
V _{OL1}	Output LOW Voltage	I _{OL} = 2.0 mA		0.45	V
V _{OL2}	Output LOW Voltage	I _{OL} = 100 μA		0.2	V
V _{IH}	Input HIGH Voltage		0.65V _{DD}	V _{DD} + 0.3	V
V _{IL}	Input LOW Voltage		-0.3	0.35V _{DD}	V
I _X	Input and Output Load Current	GND ≤ V _I ≤ V _{DD}	-5	5	μA

TAP AC Switching Characteristics Over the Operating Range ^[26, 27]

Parameter	Description	Min.	Max.	Unit
t _{TCYC}	TCK Clock Cycle Time	100		ns
t _{TF}	TCK Clock Frequency		10	MHz
t _{TH}	TCK Clock HIGH	40		ns
t _{TL}	TCK Clock LOW	40		ns
Set-up Times				
t _{TMSS}	TMS Set-up to TCK Clock Rise	10		ns
t _{TDIS}	TDI Set-up to TCK Clock Rise	10		ns
t _{CS}	Capture Set-up to TCK Rise	10		ns
Hold Times				
t _{TMSH}	TMS Hold after TCK Clock Rise	10		ns
t _{TDIH}	TDI Hold after Clock Rise	10		ns
t _{CH}	Capture Hold after Clock Rise	10		ns

Notes:

25. These characteristics pertain to the TAP inputs (TMS, TCK, TDI and TDO). Parallel load levels are specified in the Electrical Characteristics Table.
26. t_{CS} and t_{CH} refer to the set-up and hold time requirements of latching data from the boundary scan register.
27. Test conditions are specified using the load in TAP AC test conditions. t_R/t_F = 1 ns.

TAP AC Switching Characteristics Over the Operating Range (continued)^[26, 27]

Parameter	Description	Min.	Max.	Unit
Output Times				
t_{TDOV}	TCK Clock LOW to TDO Valid		20	ns
t_{TDOX}	TCK Clock LOW to TDO Invalid	0		ns

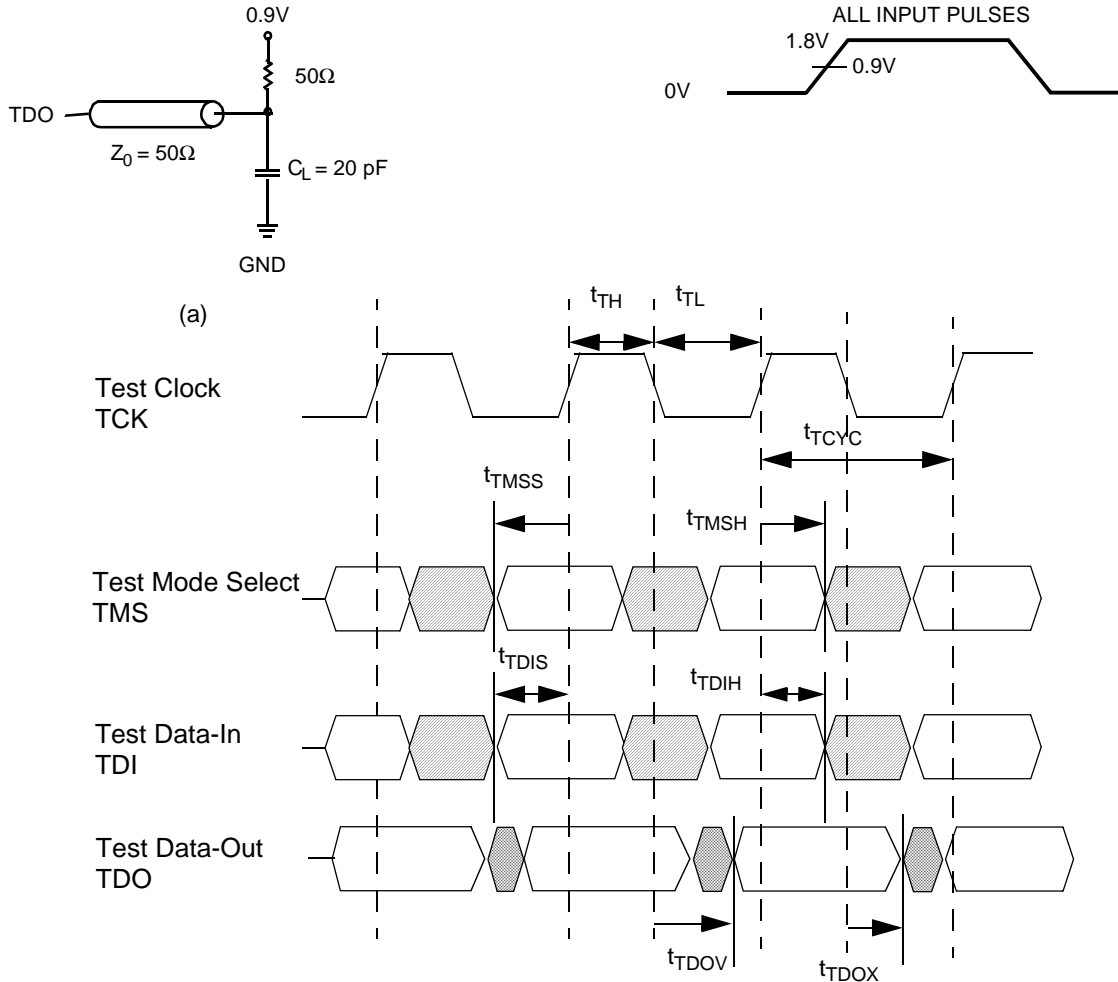
TAP Timing and Test Conditions^[27]

Identification Register Definitions

Instruction Field	Value			Description
	CY7C1311V18	CY7C1313V18	CY7C1315V18	
Revision Number (31:29)	000	000	000	Version number.
Cypress Device ID (28:12)	11010011011000101	11010011011010101	11010011011100101	Defines the type of SRAM.
Cypress JEDEC ID (11:1)	00000110100	00000110100	00000110100	Allows unique identification of SRAM vendor.
ID Register Presence (0)	1	1	1	Indicates the presence of an ID register.



Scan Register Sizes

Register Name	Bit Size
Instruction	3
Bypass	1
ID	32
Boundary Scan	107

Instruction Codes

Instruction	Code	Description
EXTEST	000	Captures the Input/Output ring contents. Places the boundary scan register between the TDI and TDO. This instruction is not 1149.1 compliant. The EXTEST command implemented by these devices will NOT place the output buffers into a high-Z condition. If the output buffers need to be in high-Z condition, this can be accomplished by deselecting the Read port.
IDCODE	001	Loads the ID register with the vendor ID code and places the register between TDI and TDO. This operation does not affect SRAM operation.
SAMPLE Z	010	Captures the Input/Output contents. Places the boundary scan register between TDI and TDO. The SAMPLE Z command implemented by these devices will place the output buffers into a high-Z condition.
RESERVED	011	Do Not Use: This instruction is reserved for future use.
SAMPLE/PRELOAD	100	Captures the Input/Output ring contents. Places the boundary scan register between TDI and TDO. Does not affect the SRAM operation. This instruction does not implement 1149.1 preload function and is therefore not 1149.1 compliant.
RESERVED	101	Do Not Use: This instruction is reserved for future use.
RESERVED	110	Do Not Use: This instruction is reserved for future use.
BYPASS	111	Places the bypass register between TDI and TDO. This operation does not affect SRAM operation.

Boundary Scan Order

Bit #	Bump ID
0	6R
1	6P
2	6N
3	7P
4	7N
5	7R
6	8R
7	8P
8	9R
9	11P
10	10P
11	10N
12	9P
13	10M
14	11N
15	9M
16	9N
17	11L
18	11M
19	9L

Boundary Scan Order (continued)

Bit #	Bump ID
20	10L
21	11K
22	10K
23	9J
24	9K
25	10J
26	11J
27	11H
28	10G
29	9G
30	11F
31	11G
32	9F
33	10F
34	11E
35	10E
36	10D
37	9E
38	10C
39	11D



Boundary Scan Order (continued)

Bit #	Bump ID
40	9C
41	9D
42	11B
43	11C
44	9B
45	10B
46	11A
47	10A
48	9A
49	8B
50	7C
51	6C
52	8A
53	7A
54	7B
55	6B
56	6A
57	5B
58	5A
59	4A
60	5C
61	4B
62	3A
63	2A
64	1A
65	2B
66	3B
67	1C
68	1B
69	3D
70	3C
71	1D
72	2C
73	3E
74	2D
75	2E
76	1E
77	2F
78	3F
79	1G
80	1F
81	3G
82	2G
83	1J

Boundary Scan Order (continued)

Bit #	Bump ID
84	2J
85	3K
86	3J
87	2K
88	1K
89	2L
90	3L
91	1M
92	1L
93	3N
94	3M
95	1N
96	2M
97	3P
98	2N
99	2P
100	1P
101	3R
102	4R
103	4P
104	5P
105	5N
106	5R

Ordering Information ^[1]

Speed (MHz)	Ordering Code	Package Name	Package Type	Operating Range
300	CY7C1311V18-300BZC	BB165A	13 x 15 mm FBGA	Commercial
	CY7C1313V18-300BZC			
	CY7C1315V18-300BZC			
250	CY7C1311V18-250BZC	BB165A	13 x 15 mm FBGA	Commercial
	CY7C1313V18-250BZC			
	CY7C1315V18-250BZC			
200	CY7C1311V18-200BZC	BB165A	13 x 15 mm FBGA	Commercial
	CY7C1313V18-200BZC			
	CY7C1315V18-200BZC			
167	CY7C1311V18-167BZC	BB165A	13 x 15 mm FBGA	Commercial
	CY7C1313V18-167BZC			
	CY7C1315V18-167BZC			

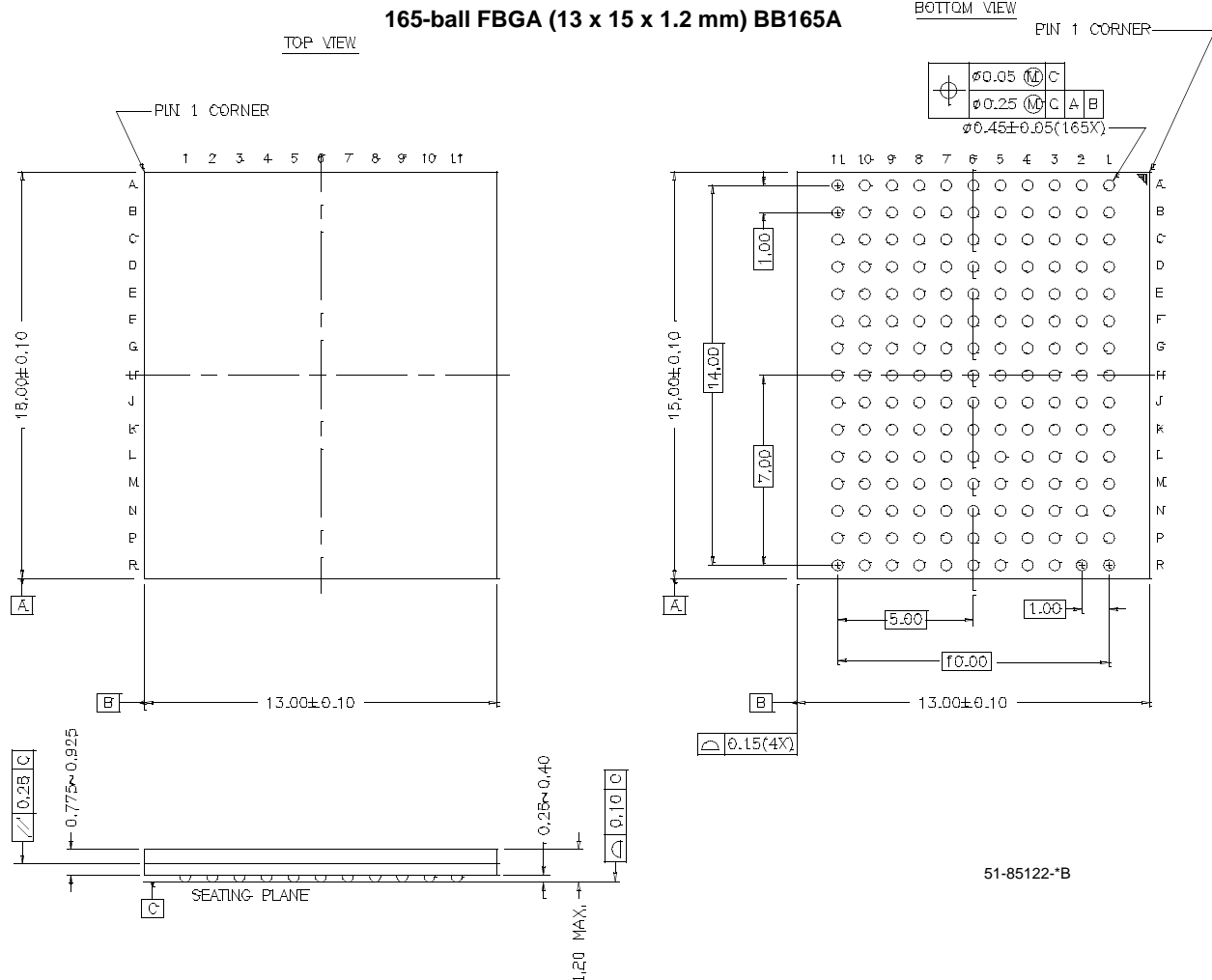
Package Diagram

QDR RAMs and Quad Data Rate RAMs comprise a new family of products developed by Cypress, Hitachi, IDT, Micron, NEC, and Samsung technology. All product and company names mentioned in this document are the trademarks of their respective holders.



PRELIMINARY

**CY7C1311V18
CY7C1313V18
CY7C1315V18**

**Document Title: CY7C1311V18/CY7C1313V18/CY7C1315V18 18-Mb QDR™-II SRAM 4-Word Burst Architecture
Document Number: 38-05181**

REV.	ECN NO.	ISSUE DATE	ORIG. OF CHANGE	DESCRIPTION OF CHANGE
**	110860	11/09/01	SKX	New Data Sheet
*A	115918	08/01/02	RCS	Changed Status to Preliminary Shaded 300-MHz Bin Updated JTAG Scan Order