

54AC/74AC161 • 54ACT/74ACT161

Synchronous Presettable Binary Counter

General Description

The 'AC/'ACT161 are high-speed synchronous modulo-16 binary counters. They are synchronously presettable for application in programmable dividers and have two types of Count Enable inputs plus a Terminal Count output for versatility in forming synchronous multistage counters. The 'AC/'ACT161 has an asynchronous Master Reset input that overrides all other inputs and forces the outputs LOW.

Features

- Synchronous counting and loading
- High-speed synchronous expansion
- Typical count rate of 125 MHz
- Outputs source/sink 24 mA
- 'ACT161 has TTL-compatible inputs
- Standard Military Drawing (SMD)
 - 'AC161: 5962-89561

Ordering Code: See Section 8

Logic Symbols

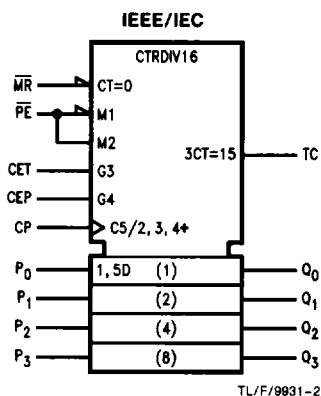
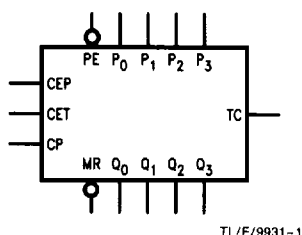

Connection Diagrams

Pin Assignment for DIP, Flatpak and SOIC

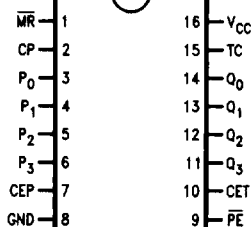

Pin Assignment for LCC

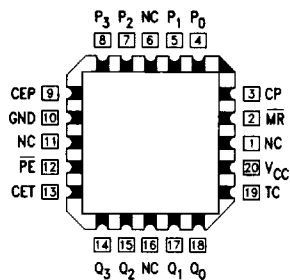

Pin Names	Description
CEP	Count Enable Parallel Input
CET	Count Enable Trickle Input
CP	Clock Pulse Input
MR	Asynchronous Master Reset Input
P ₀ -P ₃	Parallel Data Inputs
PE	Parallel Enable Inputs
Q ₀ -Q ₃	Flip-Flop Outputs
TC	Terminal Count Output



Functional Description

The 'AC/ACT161 count in modulo-16 binary sequence. From state 15 (HHHH) they increment to state 0 (LLLL). The clock inputs of all flip-flops are driven in parallel through a clock buffer. Thus all changes of the Q outputs (except due to Master Reset of the '161) occur as a result of, and synchronous with, the LOW-to-HIGH transition of the CP input signal. The circuits have four fundamental modes of operation, in order of precedence: asynchronous reset, parallel load, count-up and hold. Five control inputs—Master Reset, Parallel Enable (PE), Count Enable Parallel (CEP) and Count Enable Trickle (CET)—determine the mode of operation, as shown in the Mode Select Table. A LOW signal on MR overrides all other inputs and asynchronously forces all outputs LOW. A LOW signal on PE overrides counting and allows information on the Parallel Data (P_n) inputs to be loaded into the flip-flops on the next rising edge of CP. With PE and MR HIGH, CEP and CET permit counting when both are HIGH. Conversely, a LOW signal on either CEP or CET inhibits counting.

The 'AC/ACT161 use D-type edge-triggered flip-flops and changing the PE, CEP and CET inputs when the CP is in either state does not cause errors, provided that the recommended setup and hold times, with respect to the rising edge of CP, are observed.

The Terminal Count (TC) output is HIGH when CET is HIGH and counter is in state 15. To implement synchronous multi-stage counters, the TC outputs can be used with the CEP and CET inputs in two different ways.

Figure 1 shows the connections for simple ripple carry, in which the clock period must be longer than the CP to TC delay of the first stage, plus the cumulative CET to TC delays of the intermediate stages, plus the CET to CP setup time of the last stage. This total delay plus setup time sets the upper limit on clock frequency. For faster clock rates, the carry lookahead connections shown in Figure 2 are recommended. In this scheme the ripple delay through the intermediate stages commences with the same clock that causes the first stage to tick over from max to min in the Up mode, or min to max in the Down mode, to start its final cycle. Since this final cycle requires 16 clocks to complete, there is plenty of time for the ripple to progress through the intermediate stages. The critical timing that limits the clock period is the CP to TC delay of the first stage plus the CEP to CP setup time of the last stage. The TC output is subject

to decoding spikes due to internal race conditions and is therefore not recommended for use as a clock or asynchronous reset for flip-flops, registers or counters.

When the Output Enable (OE) is LOW, the parallel data outputs O₀–O₃ are active and follow the flip-flop Q outputs. A HIGH signal on OE forces O₀–O₃ to the High Z state but does not prevent counting, loading or resetting.

$$\text{Logic Equations: Count Enable} = \text{CEP} \cdot \text{CET} \cdot \overline{\text{PE}}$$

$$\text{TC} = \text{Q}_0 \cdot \text{Q}_1 \cdot \text{Q}_2 \cdot \text{Q}_3 \cdot \text{CET}$$

Mode Select Table

PE	CET	CEP	Action on the Rising Clock Edge (↗)
X	X	X	Reset (Clear)
L	X	X	Load (P _n → Q _n)
H	H	H	Count (Increment)
H	L	X	No Change (Hold)
H	X	L	No Change (Hold)

H = HIGH Voltage Level
L = LOW Voltage Level
X = Immaterial

State Diagram

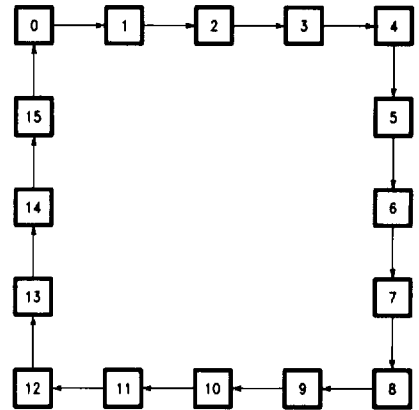

TL/F/9931-5

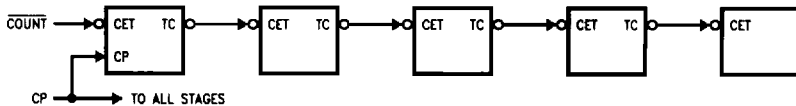

FIGURE 1. Multistage Counter with Ripple Carry

TL/F/9931-8

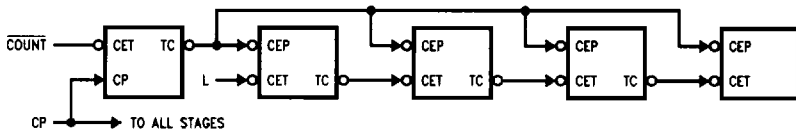
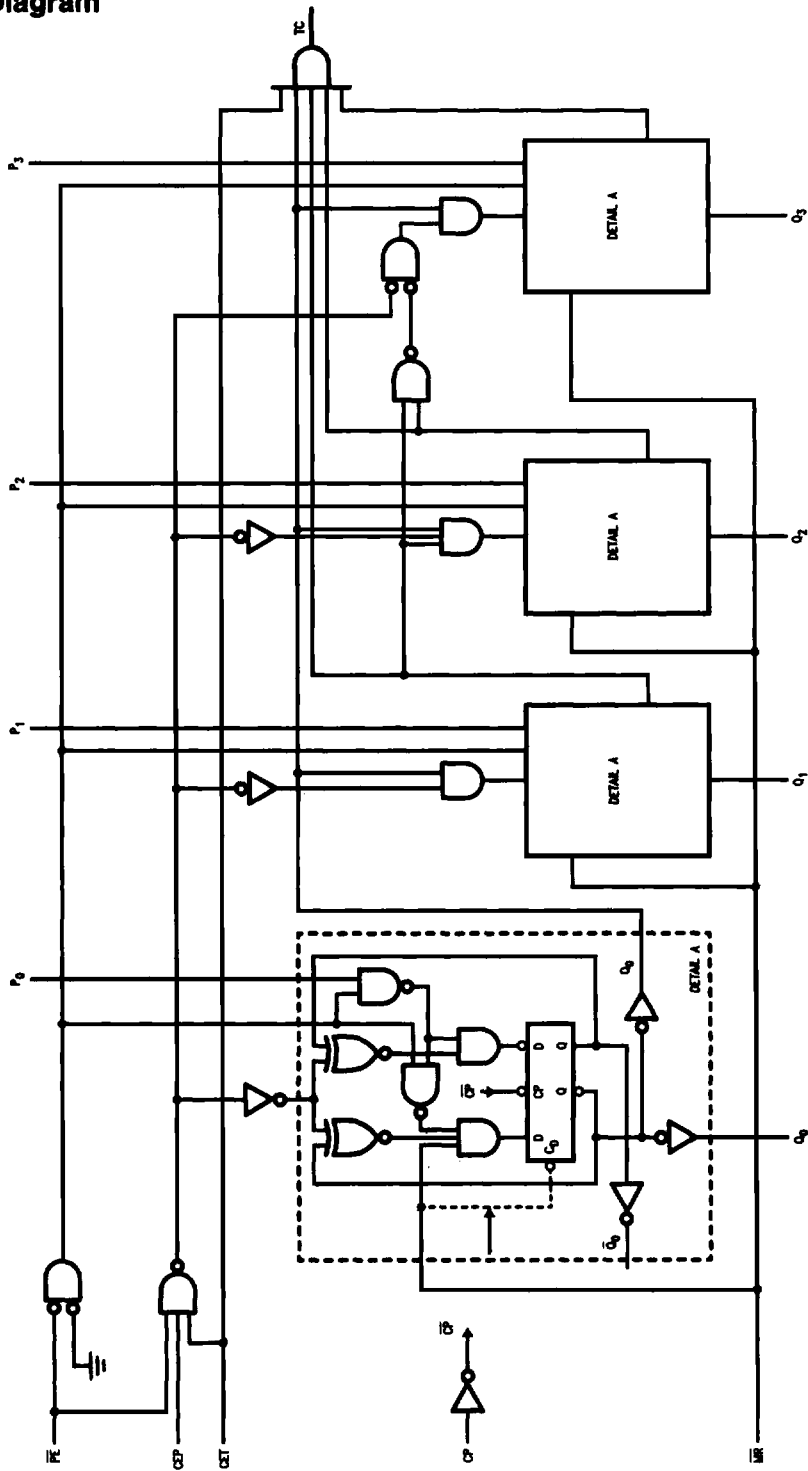

FIGURE 2. Multistage Counter with Lookahead Carry

TL/F/9931-9

Block Diagram



TL/F/9831-6

Please note that this diagram is provided only for the understanding of logic operations and should not be used to estimate propagation delays.

Absolute Maximum Ratings (Note 1)

If Military/Aerospace specified devices are required, please contact the National Semiconductor Sales Office/Distributors for availability and specifications.

Supply Voltage (V_{CC})	-0.5V to +7.0V
DC Input Diode Current (I_{IK})	
$V_I = -0.5V$	-20 mA
$V_I = V_{CC} + 0.5V$	+20 mA
DC Input Voltage (V_I)	-0.5V to $V_{CC} + 0.5V$
DC Output Diode Current (I_{OK})	
$V_O = -0.5V$	-20 mA
$V_O = V_{CC} + 0.5V$	+20 mA
DC Output Voltage (V_O)	-0.5V to $V_{CC} + 0.5V$
DC Output Source or Sink Current (I_O)	±50 mA
DC V_{CC} or Ground Current per Output Pin (I_{CC} or I_{GND})	±50 mA
Storage Temperature (T_{STG})	-65°C to +150°C
Junction Temperature (T_J)	
CDIP	175°C
PDIP	140°C

Note 1: Absolute maximum ratings are those values beyond which damage to the device may occur. The databook specifications should be met, without exception, to ensure that the system design is reliable over its power supply, temperature, and output/input loading variables. National does not recommend operation of FACT™ circuits outside databook specifications.

Recommended Operating Conditions

Supply Voltage (V_{CC})	
'AC	2.0V to 6.0V
'ACT	4.5V to 5.5V
Input Voltage (V_I)	0V to V_{CC}
Output Voltage (V_O)	0V to V_{CC}
Operating Temperature (T_A)	
74AC/ACT	-40°C to +85°C
54AC/ACT	-55°C to +125°C
Minimum Input Edge Rate ($\Delta V/\Delta t$)	
'AC Devices	
V_{IN} from 30% to 70% of V_{CC}	
V_{CC} @ 3.3V, 4.5V, 5.5V	125 mV/ns
Minimum Input Edge Rate ($\Delta V/\Delta t$)	
'ACT Devices	
V_{IN} from 0.8V to 2.0V	
V_{CC} @ 4.5V, 5.5V	125 mV/ns

DC Characteristics for 'AC Family Devices

Symbol	Parameter	V_{CC} (V)	74AC		54AC	74AC	Units	Conditions	
			$T_A = +25^\circ\text{C}$		$T_A = -55^\circ\text{C to } +125^\circ\text{C}$	$T_A = -40^\circ\text{C to } +85^\circ\text{C}$			
			Typ	Guaranteed Limits					
V_{IH}	Minimum High Level Input Voltage	3.0	1.5	2.1	2.1	2.1	V	$V_{OUT} = 0.1V$ or $V_{CC} - 0.1V$	
		4.5	2.25	3.15	3.15	3.15			
		5.5	2.75	3.85	3.85	3.85			
V_{IL}	Maximum Low Level Input Voltage	3.0	1.5	0.9	0.9	0.9	V	$V_{OUT} = 0.1V$ or $V_{CC} - 0.1V$	
		4.5	2.25	1.35	1.35	1.35			
		5.5	2.75	1.65	1.65	1.65			
V_{OH}	Minimum High Level Output Voltage	3.0	2.99	2.9	2.9	2.9	V	$I_{OUT} = -50 \mu\text{A}$	
		4.5	4.49	4.4	4.4	4.4			
		5.5	5.49	5.4	5.4	5.4			
			3.0		2.56	2.4	2.46	V	* $V_{IN} = V_{IL}$ or V_{IH} -12 mA I_{OH} -24 mA -24 mA
			4.5		3.86	3.7	3.76		
			5.5		4.86	4.7	4.76		
V_{OL}	Maximum Low Level Output Voltage	3.0	0.002	0.1	0.1	0.1	V	$I_{OUT} = 50 \mu\text{A}$	
		4.5	0.001	0.1	0.1	0.1			
		5.5	0.001	0.1	0.1	0.1			
			3.0		0.36	0.5	0.44	V	* $V_{IN} = V_{IL}$ or V_{IH} 12 mA I_{OL} 24 mA 24 mA
			4.5		0.36	0.5	0.44		
			5.5		0.36	0.5	0.44		
I_{IN}	Maximum Input Leakage Current	5.5		±0.1	±1.0	±1.0	μA	$V_I = V_{CC}, \text{GND}$	

*All outputs loaded; thresholds on input associated with output under test.

†Maximum test duration 2.0 ms, one output loaded at a time.

DC Characteristics for 'AC Family Devices (Continued)

Symbol	Parameter	V _{CC} (V)	74AC		54AC	74AC	Units	Conditions
			T _A = +25°C		T _A = -55°C to +125°C	T _A = -40°C to +85°C		
			Typ	Guaranteed Limits				
I _{OLD}	†Minimum Dynamic Output Current	5.5			50	75	mA	V _{OLD} = 1.65V Max
I _{OHD}		5.5			-50	-75	mA	V _{OHD} = 3.85V Min
I _{CC}	Maximum Quiescent Supply Current	5.5		4.0	80.0	40.0	μA	V _{IN} = V _{CC} or GND

*All outputs loaded; thresholds on input associated with output under test.

†Maximum test duration 2.0 ms, one output loaded at a time.

Note: I_{IN} and I_{CC} @ 3.0V are guaranteed to be less than or equal to the respective limit @ 5.5V V_{CC}.

I_{CC} for 54AC @ 25°C is identical to 74AC @ 25°C.

DC Characteristics for 'ACT Family Devices

Symbol	Parameter	V _{CC} (V)	74ACT		54ACT	74ACT	Units	Conditions
			T _A = +25°C		T _A = -55°C to +125°C	T _A = -40°C to +85°C		
			Typ	Guaranteed Limits				
V _{IH}	Minimum High Level Input Voltage	4.5	1.5	2.0	2.0	2.0	V	V _{OUT} = 0.1V or V _{CC} - 0.1V
		5.5	1.5	2.0	2.0	2.0		
V _{IL}	Maximum Low Level Input Voltage	4.5	1.5	0.8	0.8	0.8	V	V _{OUT} = 0.1V or V _{CC} - 0.1V
		5.5	1.5	0.8	0.8	0.8		
V _{OH}	Minimum High Level Output Voltage	4.5	4.49	4.4	4.4	4.4	V	I _{OUT} = -50 μA
		5.5	5.49	5.4	5.4	5.4		
		4.5		3.86	3.70	3.76	V	*V _{IN} = V _{IL} or V _{IH} -24 mA I _{OH} -24 mA
		5.5		4.86	4.70	4.76		
V _{OL}	Maximum Low Level Output Voltage	4.5	0.001	0.1	0.1	0.1	V	I _{OUT} = 50 μA
		5.5	0.001	0.1	0.1	0.1		
		4.5		0.36	0.50	0.44	V	*V _{IN} = V _{IL} or V _{IH} 24 mA I _{OL} 24 mA
		5.5		0.36	0.50	0.44		
I _{IN}	Maximum Input Leakage Current	5.5		±0.1	±1.0	±1.0	μA	V _I = V _{CC} , GND
I _{CC} T	Maximum I _{CC} /Input	5.5	0.6		1.6	1.5	mA	V _I = V _{CC} - 2.1V
I _{OLD}	†Minimum Dynamic Output Current	5.5			50	75	mA	V _{OLD} = 1.65V Max
I _{OHD}		5.5			-50	-75	mA	V _{OHD} = 3.85V Min
I _{CC}	Maximum Quiescent Supply Current	5.5		4.0	80.0	40.0	μA	V _{IN} = V _{CC} or GND

*All outputs loaded; thresholds on input associated with output under test.

†Maximum test duration 2.0 ms, one output loaded at a time.

Note: I_{CC} for 54ACT @ 25°C is identical to 74ACT @ 25°C.

AC Electrical Characteristics: See Section 2 for waveforms

Symbol	Parameter	V _{CC} * (V)	74AC			54AC		74AC		Units	Fig. No.
			T _A = +25°C C _L = 50 pF			T _A = -55°C to +125°C C _L = 50 pF		T _A = -40°C to +85°C C _L = 50 pF			
			Min	Typ	Max	Min	Max	Min	Max		
f _{max}	Maximum Count Frequency	3.3 5.0	70 110	111 167		55 80		60 95	MHz		
t _{PLH}	Propagation Delay CP to Q _n (PE Input HIGH or LOW)	3.3 5.0	2.0 1.5	7.0 5.0	12 9.0	1.0 1.0	15.0 11.0	1.5 1.0	13.5 9.5	ns	2-3,4
t _{PHL}	Propagation Delay CP to Q _n (PE Input HIGH or LOW)	3.3 5.0	1.5 1.5	7.0 5.0	12 9.5	1.0 1.0	15.0 11.0	1.5 1.5	13 10	ns	2-3,4
t _{PLH}	Propagation Delay CP to TC	3.3 5.0	3.0 2.0	9 6	15 10.5	1.0 1.0	18.5 13.0	2.5 1.5	16.5 11.5	ns	2-3,4
t _{PHL}	Propagation Delay CP to TC	3.3 5.0	3.5 2.0	8.5 6.5	14 11	1.0 1.0	17.5 13.0	2.5 2.0	15.5 11.5	ns	2-3,4
t _{PLH}	Propagation Delay CET to TC	3.3 5.0	2.0 1.5	5.5 3.5	9.5 6.5	1.0 1.0	13.0 8.5	1.5 1.0	11 7.5	ns	2-3,4
t _{PHL}	Propagation Delay CET to TC	3.3 5.0	2.5 2.0	6.5 5	11 8.5	1.0 1.0	14.5 11.0	2.0 1.5	12.5 9.5	ns	2-3,4
t _{PHL}	Propagation Delay MR to Q _n	3.3 5.0	2.0 1.5	6.5 5.5	12 9.5	1.0 1.0	14.5 10.5	1.5 1.5	13.5 10	ns	2-3,4
t _{PHL}	Propagation Delay MR to TC	3.3 5.0	3.5 2.5	10 8.5	15 13	1.0 1.0	18.5 14.0	3.0 2.5	17.5 13.5	ns	2-3,4

*Voltage Range 3.3 is 3.3V ± 0.3V
Voltage Range 5.0 is 5.0V ± 0.5V

AC Operating Requirements: See Section 2 for Waveforms

Symbol	Parameter	V _{CC} * (V)	74AC		54AC	74AC	Units	Fig. No.
			T _A = +25°C C _L = 50 pF		T _A = -55°C to +125°C C _L = 50 pF	T _A = -40°C to +85°C C _L = 50 pF		
			Typ	Guaranteed Minimum				
t _s	Setup Time, HIGH or LOW P _n to CP	3.3 5.0	6.0 3.5	13.5 8.5	16.0 10.5	16 10.5	ns	2-7
t _h	Hold Time, HIGH or LOW P _n to CP	3.3 5.0	-7.0 -4.0	-1 0	0.5 1.5	-0.5 0	ns	2-7
t _s	Setup Time, HIGH or LOW PE to CP	3.3 5.0	6.5 4.0	11.5 7.5	15.0 10.5	14 8.5	ns	2-7
t _h	Hold Time, HIGH or LOW PE to CP	3.3 5.0	-6.0 -3.5	0 0.5	-1.0 0.0	0 1	ns	2-7
t _s	Setup Time, HIGH or LOW CEP or CET to CP	3.3 5.0	3.0 2.0	6.0 4.5	7.5 5.5	7 5	ns	2-7
t _h	Hold Time, HIGH or LOW CEP or CET to CP	3.3 5.0	-3.5 -2	0 0	2.0 2.0	0 0.5	ns	2-7
t _w	Clock Pulse Width (Load) HIGH or LOW	3.3 5.0	2.0 2.0	3.5 2.5	5.0 5.0	4 3	ns	2-3
t _w	Clock Pulse Width (Count) HIGH or LOW	3.3 5.0	2.0 2.0	4.0 3.0	5.0 5.0	4.5 3.5	ns	2-3
t _w	MR Pulse Width, LOW	3.3 5.0	3.0 2.5	5.5 4.5	5.0 5.0	7.5 6.0	ns	2-3
t _{rec}	Recovery Time MR to CP		-2 -1	-0.5 0	1.5 2.0	0 0.5	ns	2-3,7

*Voltage Range 3.3 is 3.3V ± 0.3V
Voltage Range 5.0 is 5.0V ± 0.5V

AC Electrical Characteristics: See Section 2 for Waveforms

Symbol	Parameter	V _{CC} * (V)	74ACT			54ACT		74ACT		Units	Fig. No.
			T _A = +25°C C _L = 50 pF			T _A = -55°C to +125°C C _L = 50 pF		T _A = -40°C to +85°C C _L = 50 pF			
			Min	Typ	Max	Min	Max	Min	Max		
f _{max}	Maximum Count Frequency	5.0	115	125			100		MHz		
t _{PLH}	Propagation Delay CP to Q _n (PE Input HIGH or LOW)	5.0	1.5	5.5	9.5		1.5	10.5	ns	2-3,4	
t _{PHL}	Propagation Delay CP to Q _n (PE Input HIGH or LOW)	5.0	1.5	6.0	10.5		1.5	11.5	ns	2-3,4	
t _{PLH}	Propagation Delay CP to TC	5.0	2.0	7.0	11.0		1.5	12.5	ns	2-3,4	
t _{PHL}	Propagation Delay CP to TC	5.0	1.5	8.0	12.5		1.5	13.5	ns	2-3,4	
t _{PLH}	Propagation Delay CET to TC	5.0	1.5	5.5	8.5		1.5	10.0	ns	2-3,4	
t _{PHL}	Propagation Delay CET to TC	5.0	1.5	6.5	9.5		1.5	10.5	ns	2-3,4	
t _{PHL}	Propagation Delay MR to Q _n	5.0	1.5	6.0	10.0		1.5	11.0	ns	2-3,4	
t _{PHL}	Propagation Delay MR to TC	5.0	2.5	8.0	13.5		2.0	14.5	ns	2-3,4	

*Voltage Range 5.0 is 5.0V ± 0.5V

AC Operating Requirements: See Section 2 for Waveforms

Symbol	Parameter	V _{CC} * (V)	74ACT		54ACT	74ACT	Units	Fig. No.
			T _A = +25°C C _L = 50 pF		T _A = -55°C to +125°C C _L = 50 pF	T _A = -40°C to +85°C C _L = 50 pF		
			Typ	Guaranteed Minimum				
t _s	Setup Time, HIGH or LOW P _n to CP	5.0	4.0	9.5		11.5	ns	2-3,4
t _h	Hold Time, HIGH or LOW P _n to CP	5.0	-5.0	0		0	ns	2-3,4
t _s	Setup Time, HIGH or LOW P _E to CP	5.0	4.0	8.5		9.5	ns	2-3,4
t _h	Hold Time, HIGH or LOW P _E to CP	5.0	-5.5	-0.5		-0.5	ns	2-3,4
t _s	Setup Time, HIGH or LOW CEP or CET to CP	5.0	2.5	5.5		6.5	ns	2-3,4
t _h	Hold Time, HIGH or LOW CEP or CET to CP	5.0	-3.0	0		0	ns	2-3,4
t _w	Clock Pulse Width (Load) HIGH or LOW	5.0	2.0	3.0		3.5	ns	2-3
t _w	Clock Pulse Width (Count) HIGH or LOW	5.0	2.0	3.0		3.5	ns	2-3
t _w	M _R Pulse Width, LOW	5.0	3.0	3.0		7.5	ns	2-3
t _{rec}	Recovery Time M _R to CP	5.0	0	0		0.5	ns	2-3,7

*Voltage Range 5.0 is 5.0V ± 0.5V

Capacitance

Symbol	Parameter	Typ	Units	Conditions
C _{IN}	Input Capacitance	4.5	pF	V _{CC} = 5.0V
C _{PD}	Power Dissipation Capacitance	45.0	pF	V _{CC} = 5.0V