

SN54AHCT04, SN74AHCT04 HEX INVERTERS

SCLS232B – OCTOBER 1995 – REVISED MARCH 1996

- Inputs Are TTL-Voltage Compatible
- EPIC™ (Enhanced-Performance Implanted CMOS) Process
- High Latch-Up Immunity Exceeds 250 mA Per JEDEC Standard JESD-17
- ESD Protection Exceeds 2000 V Per MIL-STD-883C, Method 3015; Exceeds 200 V Using Machine Model (C = 200 pF, R = 0)
- Package Options Include Plastic Small-Outline (D), Shrink Small-Outline (DB), Thin Shrink Small-Outline (PW), and Ceramic Flat (W) Packages, Ceramic Chip Carriers (FK), and Standard Plastic (N) and Ceramic (J) 300-mil DIPs

description

The 'AHCT04 contain six independent inverters. These devices perform the Boolean function $Y = \bar{A}$.

The SN54AHCT04 is characterized for operation over the full military temperature range of -55°C to 125°C . The SN74AHCT04 is characterized for operation from -40°C to 85°C .

FUNCTION TABLE
(each inverter)

INPUT A	OUTPUT Y
H	L
L	H

logic symbol†

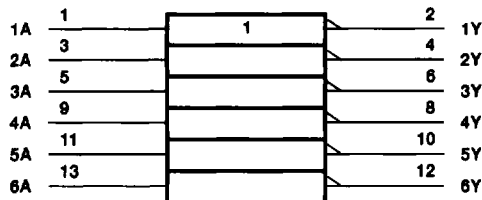

† This symbol is in accordance with ANSI/IEEE Std 91-1984 and IEC Publication 617-12. Pin numbers shown are for D, DB, J, N, PW, and W packages.

SN54AHCT04 . . . J OR W PACKAGE
SN74AHCT04 . . . D, DB, N, OR PW PACKAGE
(TOP VIEW)

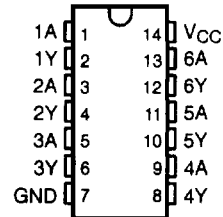

SN54AHCT04 . . . FK PACKAGE
(TOP VIEW)

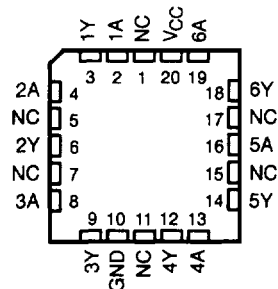

NC – No internal connection

EPIC is a trademark of Texas Instruments Incorporated.

PRODUCTION DATA information is current as of publication date. Products conform to specifications per the terms of Texas Instruments standard warranty. Production processing does not necessarily include testing of all parameters.

 **TEXAS
INSTRUMENTS**

POST OFFICE BOX 655303 • DALLAS, TEXAS 75266

Copyright © 1996, Texas Instruments Incorporated

SN54AHCT04, SN74AHCT04 HEX INVERTERS

SCLS232B – OCTOBER 1995 – REVISED MARCH 1998

logic diagram (positive logic)

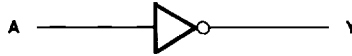

absolute maximum ratings over operating free-air temperature range (unless otherwise noted)†

Supply voltage range, V_{CC}	-0.5 V to 7 V
Input voltage range, V_I (see Note 1)	-0.5 V to 7 V
Output voltage range, V_O (see Note 1)	-0.5 V to 7 V
Input clamp current, I_{IK} ($V_I < 0$ or $V_I > V_{CC}$)	-20 mA
Output clamp current, I_{OK} ($V_O < 0$ or $V_O > V_{CC}$)	± 20 mA
Continuous output current, I_O ($V_O = 0$ to V_{CC})	± 25 mA
Continuous current through V_{CC} or GND	± 50 mA
Maximum power dissipation at $T_A = 55^\circ\text{C}$ (in still air) (see Note 2):	
D package	1.25 W
DB or PW package	0.5 W
N package	1.1 W
Storage temperature range, T_{stg}	-65°C to 150°C

† Stresses beyond those listed under "absolute maximum ratings" may cause permanent damage to the device. These are stress ratings only, and functional operation of the device at these or any other conditions beyond those indicated under "recommended operating conditions" is not implied. Exposure to absolute-maximum-rated conditions for extended periods may affect device reliability.

- NOTES: 1. The input and output voltage ratings may be exceeded if the input and output current ratings are observed.
 2. The maximum package power dissipation is calculated using a junction temperature of 150°C and a board trace length of 750 mils, except for the N package, which has a trace length of zero.

recommended operating conditions (see Note 3)

	SN54AHCT04		SN74AHCT04		UNIT
	MIN	MAX	MIN	MAX	
V_{CC} Supply voltage	4.5	5.5	4.5	5.5	V
V_{IH} High-level input voltage	2		2		V
V_{IL} Low-level input voltage		0.8		0.8	V
V_I Input voltage	0	5.5	0	5.5	V
V_O Output voltage	0	V_{CC}	0	V_{CC}	V
I_{OH} High-level output current		-8		-8	mA
I_{OL} Low-level output current		8		8	mA
$\Delta t/\Delta v$ Input transition rise or fall rate		20		20	ns/V
T_A Operating free-air temperature	-55	125	-40	85	$^\circ\text{C}$

NOTE 3: Unused inputs must be held high or low to prevent them from floating.



SN54AHCT04, SN74AHCT04 HEX INVERTERS

SCLS232B – OCTOBER 1995 – REVISED MARCH 1998

electrical characteristics over recommended operating free-air temperature range (unless otherwise noted)

PARAMETER	TEST CONDITIONS	V _{CC}	T _A = 25°C			SN54AHCT04		SN74AHCT04		UNIT
			MIN	TYP	MAX	MIN	MAX	MIN	MAX	
V _{OH}	I _{OH} = -50 μA	4.5 V	3.15	3.65		3.15		3.15	V	
	I _{OH} = -8 mA		2.5			2.4		2.4		
V _{OL}	I _{OL} = 50 μA	4.5 V			0.1			0.1	V	
	I _{OL} = 8 mA				0.36		0.44	0.44		
I _I	V _I = V _{CC} or GND	5.5 V			±0.1		±1	±1	μA	
I _{CC}	V _I = V _{CC} or GND, I _O = 0	5.5 V			2		20	20	μA	
ΔI _{CC} †	One input at 3.4 V, Other inputs at V _{CC} or GND	5.5 V			1.35		1.5	1.5	mA	
C _I	V _I = V _{CC} or GND	5 V		4	10			10	pF	

† This is the increase in supply current for each input at one of the specified TTL voltage levels rather than 0 V or V_{CC}.

switching characteristics over recommended operating free-air temperature range, V_{CC} = 5 V ± 0.5 V (unless otherwise noted) (see Figure 1)

PARAMETER	FROM (INPUT)	TO (OUTPUT)	LOAD CAPACITANCE	SN54AHCT04				UNIT	
				T _A = 25°C			MIN		MAX
				MIN	TYP	MAX			
t _{PLH} *	A	Y	C _L = 15 pF	4.7	6.7	1	7.5	ns	
t _{PHL} *				4.7	6.7	1	7.5		
t _{PLH}	A	Y	C _L = 50 pF	5.5	7.7	1	8.5	ns	
t _{PHL}				5.5	7.7	1	8.5		

* On products compliant to MIL-PRF-38535, this parameter is ensured but not production tested.

switching characteristics over recommended operating free-air temperature range, V_{CC} = 5 V ± 0.5 V (unless otherwise noted) (see Figure 1)

PARAMETER	FROM (INPUT)	TO (OUTPUT)	LOAD CAPACITANCE	SN74AHCT04				UNIT	
				T _A = 25°C			MIN		MAX
				MIN	TYP	MAX			
t _{PLH}	A	Y	C _L = 15 pF	4.7	6.7	1	7.5	ns	
t _{PHL}				4.7	6.7	1	7.5		
t _{PLH}	A	Y	C _L = 50 pF	5.5	7.7	1	8.5	ns	
t _{PHL}				5.5	7.7	1	8.5		

noise characteristics, V_{CC} = 5 V, C_L = 50 pF, T_A = 25°C (see Note 4)

PARAMETER	DESCRIPTION	SN74AHCT04			UNIT
		MIN	TYP	MAX	
V _{OL(P)}	Quiet output, maximum dynamic V _{OL}		0.8		V
V _{OL(V)}	Quiet output, minimum dynamic V _{OL}		-0.8		V
V _{IH(D)}	High-level dynamic input voltage	2			V
V _{IL(D)}	Low-level dynamic input voltage			0.8	V

NOTE 4: Characteristics are determined during product characterization and ensured by design for surface-mount packages only.



SN54AHCT04, SN74AHCT04 HEX INVERTERS

SCLS232B – OCTOBER 1985 – REVISED MARCH 1986

operating characteristics, $V_{CC} = 5\text{ V}$, $T_A = 25^\circ\text{C}$

PARAMETER	TEST CONDITIONS	TYP	UNIT
C_{pd} Power dissipation capacitance	No load, $f = 1\text{ MHz}$	14	pF

PARAMETER MEASUREMENT INFORMATION

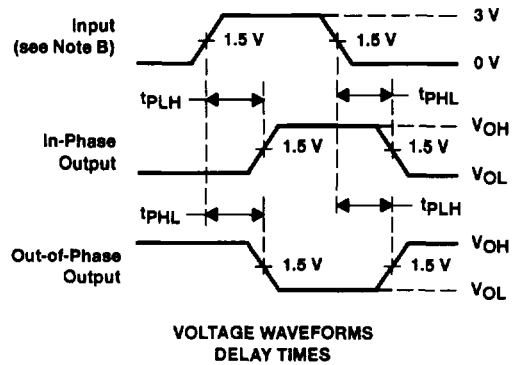
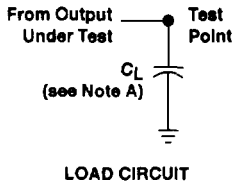

- NOTES: A. C_L includes probe and jig capacitance.
 B. All input pulses are supplied by generators having the following characteristics: $PRR \leq 1\text{ MHz}$, $Z_O = 50\ \Omega$, $t_r = 3\text{ ns}$, $t_f = 3\text{ ns}$.
 C. The outputs are measured one at a time with one input transition per measurement.

Figure 1. Load Circuit and Voltage Waveforms