

GD54/74HC244, GD54/74HCT244

Absolute Maximum Ratings

SYMBOL	PARAMETER	CONDITIONS	MIN	MAX	UNIT
V_{CC}	DC Supply voltage		-0.5	+7	V
I_{IK}, I_{OK}	DC input or output diode current	for $V_I < -0.5$ or $V_I > V_{CC} + 0.5V$		20	mA
I_O	DC output source or sink current	for $-0.5V < V_O < V_{CC} + 0.5V$		35	mA
I_{CC}	DC V_{CC} or GND current			70	mA
T_{stg}	Storage temperature range		-65	150	°C
P_D	Power dissipation per package	above +70°C derate linearly with 8mW/K		500	mW
T_L	Lead temperature	At distance 1.16 ± 1.32 in from case for 60 sec(CERAMIC) 10 sec(PLASTIC)		300 260	°C

Recommended Operating Conditions

CHARACTERISTIC	LIMITS		UNITS
	MIN.	MAX.	
Supply-Voltage Range V_{CC} : GD54/74HC Types GD54/74HCT Types	2 4.5	6 5.5	V
DC Input or Output Voltage V_I, V_O	0	V_{CC}	V
Operating Temperature T_A : GD74 Types GD54 Types	-40 -55	+85 +125	°C
Input Rise and Fall times t_r, t_f : GD54/74HC Types at 2V at 4.5V at 6V , GD54/74HCT Types at 4.5V		1000 500 400 500	ns

Logic Diagram

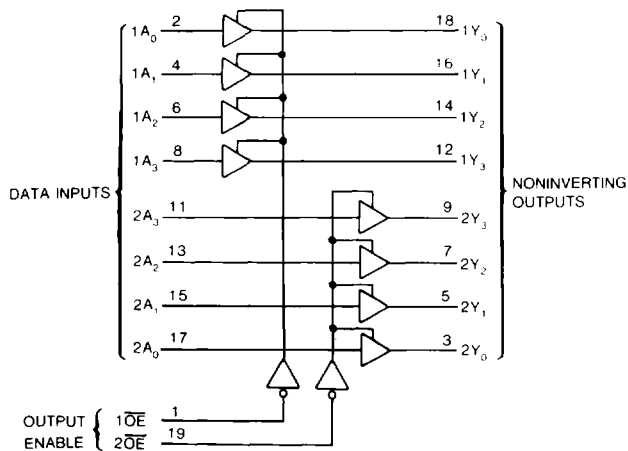

Fig. 2 Logic diagram

DC Electrical Characteristics for HC

SYMBOL	PARAMETER	TEST CONDITION	V _{CC} (V)	T _A =25°C			GD74HC244		GD54HC244		UNIT	
				MIN	TYP	MAX	MIN	MAX	MIN	MAX		
V _{IH}	HIGH level input Voltage		2.0	1.5			1.5		1.5		V	
			4.5	3.15			3.15		3.15			
			6.0	4.2			4.2		4.2			
V _{IL}	LOW level input voltage		2.0			0.3		0.3		0.3	V	
			4.5			0.9		0.9		0.9		
			6.0			1.2		1.2		1.2		
V _{OH}	HIGH level output voltage	V _{IN} =V _{IH} or V _{IL}	I _{OH} =-20μA	2.0	1.9	2.0		1.9		1.9	V	
			I _{OH} =-6mA	4.5	4.4	4.5		4.4		4.4		
			I _{OH} =-7.8mA	6.0	5.9	6.0		5.9		5.9		
V _{OL}	LOW level output voltage	V _{IN} =V _{IH} or V _{IL}	I _{OL} =20μA	2.0			0.1		0.1		V	
			I _{OL} =6mA	4.5		0.17	0.26		0.33			0.4
			I _{OL} =7.8mA	6.0		0.15	0.26		0.33			0.4
I _{IN}	Input leakage Current	V _{IN} =V _{CC} or GND	6.0			0.1		1.0		1.0	μA	
I _{OZ}	Three-State leakage current	V _{IN} =V _{IH} or V _{IL} V _O =V _{CC} or GND	6.0		0.01	0.5		5.0		10.0	μA	
I _{CC}	Quiescent Supply Current	V _{IN} =V _{CC} or GND I _{out} =0μA	6.0			8		80		160	μA	

DC Electrical Characteristics for HCT

SYMBOL	PARAMETER	TEST CONDITION	V _{CC} (V)	T _A =25°C			GD74HCT244		GD54HCT244		UNIT	
				MIN	TYP	MAX	MIN	MAX	MIN	MAX		
V _{IH}	HIGH level input Voltage		4.5								V	
			5.0	2.0			2.0		2.0			
V _{IL}	LOW level input voltage		4.5								V	
			5.5			0.8		0.8		0.8		
V _{OH}	HIGH level output voltage	V _{IN} =V _{IH} or V _{IL}	I _{OH} =-20μA	4.5	4.4	4.5		4.4		4.4	V	
			I _{OH} =-6mA	4.5	3.98	4.3		3.84		3.7		
			I _{OH} =-7.8mA	6.0								
V _{OL}	LOW level output voltage	V _{IN} =V _{IH} or V _{IL}	I _{OL} =20μA	4.5			0.1		0.1		V	
			I _{OL} =6mA	4.5		0.17	0.26		0.33			0.4
			I _{OL} =7.8mA	6.0								
I _{IN}	Input leakage Current	V _{IN} =V _{CC} or GND	5.5			0.1		1.0		1.0	μA	
I _{OZ}	Three-State leakage current	V _{IN} =V _{IH} or V _{IL} V _O =V _{CC} or GND	5.5		0.01	0.5		5.0		10.0	μA	
I _{CC}	Quiescent Supply Current	V _{IN} =V _{CC} or GND I _{out} =0μA	5.5			8		80		160	μA	

GD54/74HC244, GD54/74HCT244

AC Characteristics for HC: $t_r=t_f=6\text{ns}$ $C_L=50\text{ pF}$

SYMBOL	PARAMETER	V_{CC} (V)	$T_A=25^\circ\text{C}$			GD74HC244		GD54HC244		UNIT
			MIN.	TYP.	MAX.	MIN.	MAX.	MIN.	MAX.	
t_{PLH} / t_{PHL}	Propagation Delay Time	2.0		30	100		120		140	ns
	nA_n to nY_n	4.5		9	18		24		28	
		6.0		8	16		20		25	
t_{PZH} / t_{PZL}	3-state Output Enable Time	2.0		35	140		180		210	ns
	$n\overline{OE}$ to nY_n	4.5		10	28		36		42	
		6.0		9	26		32		36	
t_{PLZ} / t_{PHZ}	3-state Output Disable Time	2.0		35	140		180		210	ns
	$n\overline{OE}$ to nY_n	4.5		10	28		36		42	
		6.0		9	26		32		36	
t_{TLH} / t_{THL}	Output Transition Time	2.0		15	60		75		90	ns
		4.5		6	12		15		18	
		6.0		5	10		13		15	

AC Characteristics for HCT: $t_r=t_f=6\text{ns}$ $C_L=50\text{ pF}$

SYMBOL	PARAMETER	V_{CC} (V)	$T_A=25^\circ\text{C}$			GD74HCT244		GD54HCT244		UNIT
			MIN.	TYP.	MAX.	MIN.	MAX.	MIN.	MAX.	
t_{max}	Propagation Delay Time nA_n to nY_n	4.5		12	22		26		30	ns
t_{PLH} / t_{PHL}	Propagation Delay Time $n\overline{OE}$ to nY_n	4.5		18	30		38		45	ns
t_{PLH} / t_{PHL}	Propagation Delay Time $n\overline{OE}$ to nY_n	4.5		15	25		32		38	ns
t_{TLH} / t_{THL}	Output Transition Time	4.5		7	12		15		18	ns

AC Waveforms

