

7486, LS86, S86 Gates

Quad Two-Input Exclusive-OR Gate Product Specification

Logic Products

TYPE	TYPICAL PROPAGATION DELAY	TYPICAL SUPPLY CURRENT (TOTAL)
7486	14ns	30mA
74LS86	10ns	6.1mA
74S86	7ns	50mA

ORDERING CODE

PACKAGES	COMMERCIAL RANGE $V_{CC} = 5V \pm 5\%$; $T_A = 0^\circ C$ to $+70^\circ C$
Plastic DIP	N7486N, N74LS86N, N74S86N
Plastic SO	N74LS86D, N74S86D

FUNCTION TABLE

INPUTS		OUTPUT
A	B	Y
L	L	L
L	H	H
H	L	H
H	H	L

H = HIGH voltage level
L = LOW voltage level

NOTE:

For information regarding devices processed to Military Specifications, see the Signetics Military Products Data Manual.

INPUT AND OUTPUT LOADING AND FAN-OUT TABLE

PINS	DESCRIPTION	74	74S	74LS
A, B	Inputs	1ul	1Sul	1LSul
Y	Output	10ul	10Sul	10LSul

NOTE:

Where a 74 unit load (ul) is understood to be $40\mu A I_{IH}$ and $-1.6mA I_{IL}$, a 74S unit load (Sul) is $50\mu A I_{IH}$ and $-2.0mA I_{IL}$, and a 74LS unit load (LSul) is $20\mu A I_{IH}$ and $-0.4mA I_{IL}$.

PIN CONFIGURATION

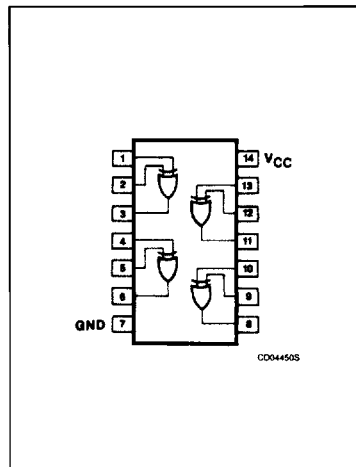

LOGIC SYMBOL

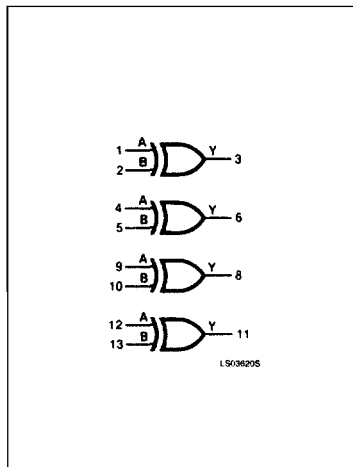

LOGIC SYMBOL (IEEE/IEC)

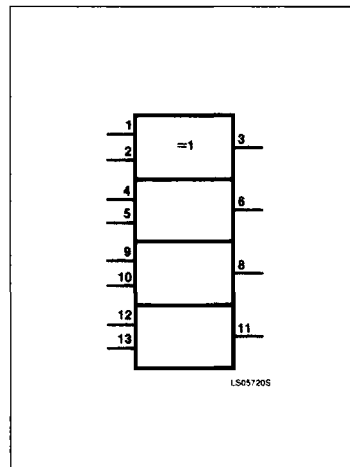

Gates

7486, LS86, S86

ABSOLUTE MAXIMUM RATINGS (Over operating free-air temperature range unless otherwise noted.)

PARAMETER	74	74LS	74S	UNIT
V _{CC} Supply voltage	7.0	7.0	7.0	V
V _{IN} Input voltage	-0.5 to +5.5	-0.5 to +7.0	-0.5 to +5.5	V
I _{IN} Input current	-30 to +5	-30 to +1	-30 to +5	mA
V _{OUT} Voltage applied to output in HIGH output state	-0.5 to +V _{CC}	-0.5 to +V _{CC}	-0.5 to +V _{CC}	V
T _A Operating free-air temperature range	0 to 70			°C

RECOMMENDED OPERATING CONDITIONS

PARAMETER	74			74LS			74S			UNIT
	Min	Nom	Max	Min	Nom	Max	Min	Nom	Max	
V _{CC} Supply voltage	4.75	5.0	5.25	4.75	5.0	5.25	4.75	5.0	5.25	V
V _{IH} HIGH-level input voltage	2.0			2.0			2.0			V
V _{IL} LOW-level input voltage			+0.8			+0.8			+0.8	V
I _{IK} Input clamp current			-12			-18			-18	mA
I _{OH} HIGH-level output current			-800			-400			-1000	μA
I _{OL} LOW-level output current			16			8			20	mA
T _A Operating free-air temperature	0	70	0	0	70	0	0	70	0	°C



TEST CIRCUITS AND WAVEFORMS

10C28405

WF064305

V_M = 1.3V for 74LS; V_M = 1.5V for all other TTL families.

Test Circuit For 74 Totem-Pole Outputs

DEFINITIONS

R_L = Load resistor to V_{CC}; see AC CHARACTERISTICS for value.
 C_L = Load capacitance includes jig and probe capacitance; see AC CHARACTERISTICS for value.
 R_T = Termination resistance should be equal to Z_{OUT} of Pulse Generators.
 D = Diodes are 1N916, 1N3064, or equivalent.
 t_{TLH}, t_{THL} Values should be less than or equal to the table entries.

FAMILY	INPUT PULSE REQUIREMENTS				
	Amplitude	Rep. Rate	Pulse Width	t _{TLH}	t _{THL}
74	3.0V	1MHz	500ns	7ns	7ns
74LS	3.0V	1MHz	500ns	15ns	6ns
74S	3.0V	1MHz	500ns	2.5ns	2.5ns

Gates

7486, LS86, S86

DC ELECTRICAL CHARACTERISTICS (Over recommended operating free-air temperature range unless otherwise noted.)

PARAMETER	TEST CONDITIONS ¹	7486			74LS86			74S86			UNIT
		Min	Typ ²	Max	Min	Typ ²	Max	Min	Typ ²	Max	
V _{OH} HIGH-level output voltage	V _{CC} = MIN, V _{IH} = MIN, V _{IL} = MAX, I _{OH} = MAX	2.4	3.4		2.7	3.4		2.7	3.4		V
V _{OL} LOW-level output voltage	V _{CC} = MIN, V _{IH} = MIN, V _{IL} = MAX	I _{OL} = MAX		0.2	0.4		0.35	0.5		0.5	V
		I _{OL} = 4mA (74LS)					0.25	0.4			
V _{IK} Input clamp voltage	V _{CC} = MIN, I _I = I _{IK}			-1.5			-1.5			-1.2	V
I _I Input current at maximum input voltage	V _{CC} = MAX	V _I = 5.5V			1.0					1.0	mA
		V _I = 7.0V					0.2				mA
I _{IH} HIGH-level input current	V _{CC} = MAX	V _I = 2.4V			40						μA
		V _I = 2.7V					40		50		μA
I _{IL} LOW-level input current	V _{CC} = MAX	V _I = 0.4V			-1.6		-0.8				mA
		V _I = 0.5V							-2.0		mA
I _{OS} Short-circuit output current ³	V _{CC} = MAX	-18		-55	-15		-100	-40		-100	mA
I _{CC} Supply current ⁴ (total)	V _{CC} = MAX		30	50		6.1	10		50	75	mA

NOTES:

- For conditions shown as MIN or MAX, use the appropriate value specified under recommended operating conditions for the applicable type.
- All typical values are at V_{CC} = 5V, T_A = 25°C.
- I_{OS} is tested with V_{OUT} = +0.5V and V_{CC} = V_{CC} MAX + 0.5V. Not more than one output should be shorted at a time and duration of the short circuit should not exceed one second.
- I_{CC} is measured with inputs grounded and outputs open.

AC WAVEFORMS

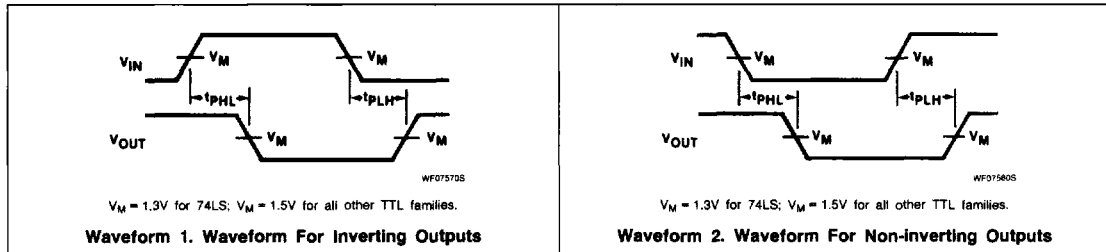

AC ELECTRICAL CHARACTERISTICS T_A = 25°C, V_{CC} = 5.0V

PARAMETER	TEST CONDITIONS	74		74LS		74S		UNIT
		C _L = 15pF, R _L = 400Ω		C _L = 15pF, R _L = 2kΩ		C _L = 15pF, R _L = 280Ω		
		Min	Max	Min	Max	Min	Max	
t _{PLH} Propagation delay A or B to output	Other input LOW Waveform 2		23		23		10.5	ns
t _{PHL}			17		17		10	
t _{PLH} Propagation delay A or B to output	Other input HIGH Waveform 1		30		30		10.5	ns
t _{PHL}			22		22		10	