

Serie 19000

Technische Daten / Technical data



## Technische Daten Technical data

	<b>Crimp Crimp</b> (Seite 48 / 50 - 54) (Page 48 / 50 - 54)	<b>Schneidklemm IDC</b> (Seite 49 / 52 / 54) (Page 49 / 52 / 54)	<b>Einlötsstecker Board-in connector</b> (Seite 55) (Page 55)
<b>Mechanisch Mechanical</b>			
Raster Pitch	2,5 mm	2,5 mm	2,5 mm
Polzahl Positions	bis 20 up to 20	bis 8 up to 8	bis 15 up to 15
Anschlußart Termination	crimpen, löten crimp, soldering	IDC, löten IDC, soldering	crimpen, löten crimp, soldering
Betriebstemperatur Operating temperature	-40 °C + 110 °C	-40 °C + 110 °C	-40 °C + 110 °C
<b>Elektrisch Electrical</b>			
Strombelastbarkeit Current rating	3A / 70 °C	2A / 70 °C	3A / 70 °C
Isolationswiderstand Insulation resistance	>10 <sup>9</sup> Ohm	>10 <sup>9</sup> Ohm	>10 <sup>9</sup> Ohm
Durchgangswiderstand Contact resistance	<10 m Ohm	<10 m Ohm	<10 m Ohm
Prüfspannung DIN 41640 Test voltage DIN 41640	1500 V AC	1500 V AC	1500 V AC
<b>Werkstoffe Materials</b>			
Isolierkörper Housing	PBT-V0	PBT-V0	PA 6.6-V0
Kontakt Contact	CuSn	CuSn	CuZn
Kontaktoberfläche Finishing	verzinkt tin plated	verzinkt tin plated	verzinkt tin plated
Detaillierte Informationen auf Anfrage! Please ask for detailed data!			

**Stiftwannen mit Stift Ø 0,6 mm**  
**Pin connectors with pin Ø 0.6 mm**

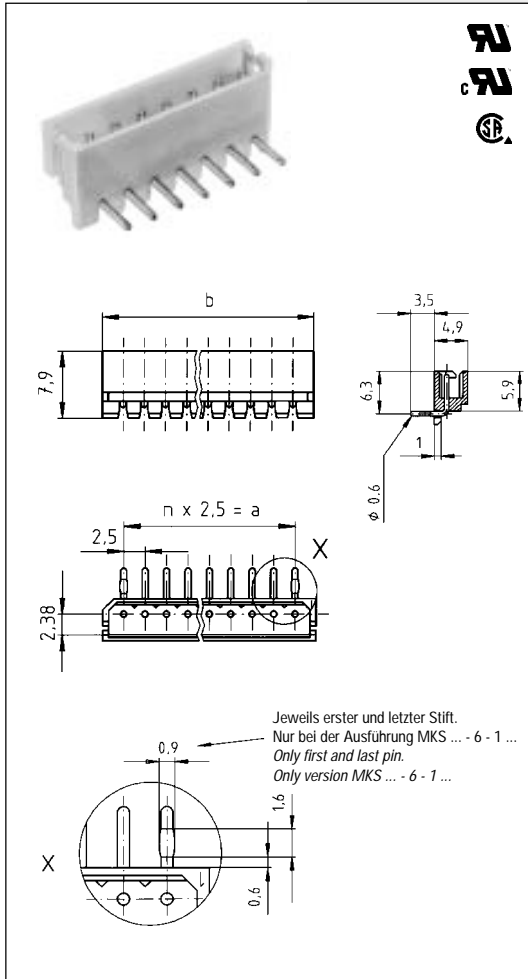

Serie MKS 19090, Stiftwanne liegend  
 Series MKS 19090, Pin connector for horizontal connections

Polzahl Positions	Artikel-Nummer Part number	Abmessungen A Dimensions A	Abmessungen B Dimensions B
2	MKS 19092 - 6 - * - 202	2,5	7,4
3	MKS 19093 - 6 - * - 303	5,0	9,9
4	MKS 19094 - 6 - * - 404	7,5	12,4
5	MKS 19095 - 6 - * - 505	10,0	14,9
6	MKS 19096 - 6 - * - 606	12,5	17,4
7	MKS 19097 - 6 - * - 707	15,0	19,9
8	MKS 19098 - 6 - * - 808	17,5	22,4
9	MKS 19099 - 6 - * - 909	20,0	24,9
10	MKS 19100 - 6 - * - 1010	22,5	27,4
11	MKS 19101 - 6 - * - 1111	25,0	29,9
12	MKS 19102 - 6 - * - 1212	27,5	32,4
13	MKS 19103 - 6 - * - 1313	30,0	34,9
14	MKS 19104 - 6 - * - 1414	32,5	37,4
15	MKS 19105 - 6 - * - 1515	35,0	39,9
16	MKS 19106 - 6 - * - 1616	37,5	42,4
17	MKS 19107 - 6 - * - 1717	40,0	44,9
18	MKS 19108 - 6 - * - 1818	42,5	47,4
19	MKS 19109 - 6 - * - 1919	45,0	49,9
20	MKS 19110 - 6 - * - 2020	47,5	52,4

\* Bitte fügen Sie hier die **Kennziffer** für die Stiftversion gemäß folgender Tabelle ein.  
 \* Please enter here the **code number** for the pin version as indicated in the chart below.

Stiftversion Pin version	Kennziffer Code number
-----------------------------	---------------------------

Stift Ø 0,6 mm Pin Ø 0.6 mm	0
--------------------------------	---

Stift Ø 0,6 mm mit Sicke im Einlötbereich Pin Ø 0.6 mm with kinked solder area	1
---	---