

PANEL CUTOUT

PANEL THICKNESS	(x)
0.75 - 1.25	30.0
1.25 - 2.00	30.4
2.00 - 3.00	30.7

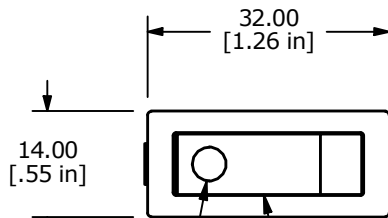

▲ LENS COLOR: TRANSPARENT AMBER  
 ▲ ACTUATOR COLOR: BLACK  
 ▲ BODY COLOR: BLACK



SWITCH FUNCTION	
POS. 1	POS. 2
OFF	ON
NONE	2-1

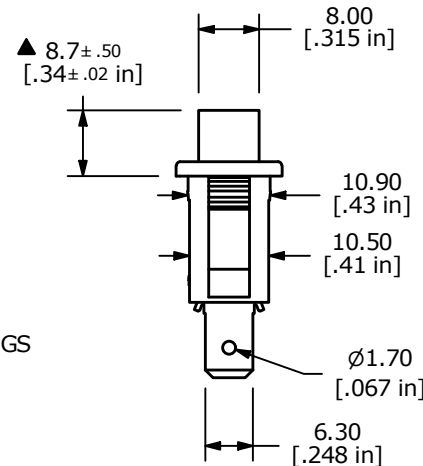
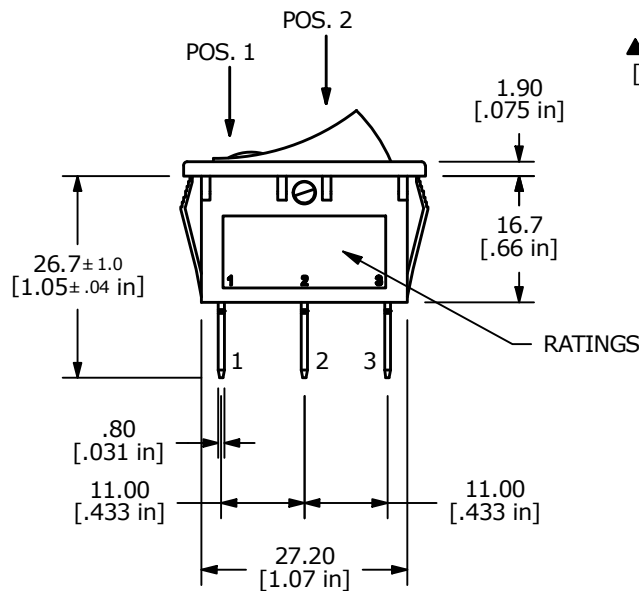
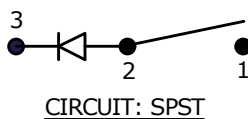

NOTE:

- DIMENSIONS IN MM [INCH]
- GENERAL TOLERANCE: X.X = ± 0.4  
X.XX = ± 0.25
- TERMINAL NUMBERS FOR REF ONLY
- CONTACT MATERIAL: SILVER
- CONTACT RATINGS:  
ANSI/UL 1054 AND CAN/CSA C22.2 NO.55 (E194579):  
15A @ 125VAC [cURus]  
7.5A @ 250VAC [cURus]  
EN 61058-1:2002+A2 (SE/09138-1):
- CONTACT RESISTANCE: 35mΩ MAX. @ 50VAC INITIAL
- INSULATION RESISTANCE: 100MΩ MIN. @ 500VDC
- DIELECTRIC STRENGTH: 1,500VAC FOR 1 MINUTE
- ELECTRICAL LIFE: 6,000 CYCLES [cURus]
- OPERATING TEMPERATURE: -20°C to 85°C [cURus]
- ILLUMINATION VOLTAGE: 12V LED
- ▲ DENOTES CRITICAL PARAMETER

REV	ECO NO	DESCRIPTION	DATE	BY
F	ECO-100575	REMOVE VDE/ENCE RATING AND LOGO	01/04/22	JS



OBJECT ID  
000001461

TITLE RB141C1100-224				
SCALE 1:1	DATE 5/3/2011	DR MW	DWG 38-RB141C1100224	REV F