

TMS29F400T, TMS29F400B
524288 BY 8-BIT/262144 BY 16-BIT
FLASH MEMORIES

SMJS843A – MAY 1997 – REVISED SEPTEMBER 1997

- **Single Power Supply Supports 5 V ± 10% Read/Write Operation**
- **Organization . . . 524288 By 8 Bits
262144 By 16 Bits**
- **Array-Blocking Architecture**
 - One 16K-Byte/One 8K-Word Boot Sector
 - Two 8K-Byte/4K-Word Parameter Sectors
 - One 32K-Byte/16K-Word Sector
 - Seven 64K-Byte/32K-Word Sectors
 - Any Combination of Sectors Can Be Erased. Supports Full-Chip Erase
 - Any Combination of Sectors Can Be Marked as Read-Only
- **Boot-Code Sector Architecture**
 - T = Top Sector
 - B = Bottom Sector
- **Sector Protection**
 - Hardware Protection Method That Disables Any Combination of Sectors From Write or Erase Operations Using Standard Programming Equipment
- **Embedded Program/Erase Algorithms**
 - Automatically Pre-Programs and Erases Any Sector
 - Automatically Programs and Verifies the Program Data at Specified Address
- **JEDEC Standards**
 - Compatible With JEDEC Byte Pinouts
 - Compatible With JEDEC EEPROM Command Set
- **Fully Automated On-Chip Erase and Program Operations**
- **100 000 Program/Erase Cycles**
- **Low Power Dissipation**
 - 40-mA Typical Active Read for Byte Mode
 - 50-mA Typical Active Read for Word Mode
 - 60-mA Typical Program/Erase Current
 - Less Than 100- μ A Standby Current
 - 5 μ A in Deep Power-Down Mode
- **All Inputs/Outputs TTL-Compatible**
- **Erase Suspend/Resume**
 - Supports Reading Data From, or Programming Data to, a Sector Not Being Erased
- **Hardware-Reset Pin Initializes the Internal-State Machine to the Read Operation**
- **Package Options**
 - 44-Pin Plastic Small-Outline Package (PSOP) (DBJ Suffix)
 - 48-Pin Thin Small-Outline Package (TSOP) (DCD Suffix)
- **Detection Of Program/Erase Operation**
 - Data Polling and Toggle Bit Feature of Program/Erase Cycle Completion
 - Hardware Method for Detection of Program/Erase Cycle Completion Through Ready/Busy (RY/BY) Output Pin
- **High-Speed Data Access at 5-V V_{CC} ± 10% at Three Temperature Ranges**
 - 80 ns Commercial . . . 0°C to 70°C
 - 90 ns Commercial . . . 0°C to 70°C
 - 100 ns Extended . . . –40°C to 85°C
 - 120 ns Automotive . . . –40°C to 125°C

PIN NOMENCLATURE	
A[0:17]	Address Inputs
$\overline{\text{BYTE}}$	Byte/Word Enable
DQ[0:14]	Data In/Data out
DQ15/A _{L-1}	Data In/Out (Word-Wide Mode)
$\overline{\text{A}}_0$	Low-Order Address (Byte-Wide Mode)
$\overline{\text{CE}}$	Chip Enable
$\overline{\text{OE}}$	Output Enable
NC	No Internal Connection
$\overline{\text{RESET}}$	Reset/Deep Power Down
RY/ $\overline{\text{BY}}$	Ready/Busy Output
V _{CC}	Power Supply
V _{SS}	Ground
$\overline{\text{WE}}$	Write Enable

PRODUCT PREVIEW



Please be aware that an important notice concerning availability, standard warranty, and use in critical applications of Texas Instruments semiconductor products and disclaimers thereto appears at the end of this data sheet.

PRODUCT PREVIEW information concerns products in the formative or design phase of development. Characteristic data and other specifications are design goals. Texas Instruments reserves the right to change or discontinue these products without notice.



POST OFFICE BOX 655303 • DALLAS, TEXAS 75265
 POST OFFICE BOX 1443 • HOUSTON, TEXAS 77251-1443

Copyright © 1997, Texas Instruments Incorporated

TMS29F400T, TMS29F400B
524288 BY 8-BIT/262144 BY 16-BIT
FLASH MEMORIES

SMJS843A – MAY 1997 – REVISED SEPTEMBER 1997

**44-PIN PSOP
 DBJ PACKAGE
 (TOP VIEW)**

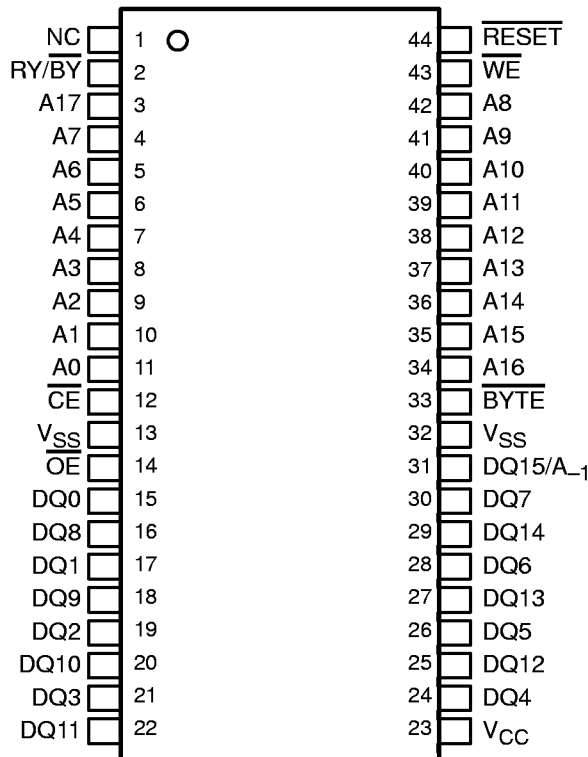

PRODUCT PREVIEW

description

The TMS29F400T/B is a 524288 by 8-bit/262144 by 16-bit (4194304-bit), 5-V single-supply, programmable read-only memory device that can be electrically erased and reprogrammed. This device is organized as 512K by 8 bits or 256K by 16 bits, divided into 11 sectors:

- One 16K-byte/8K-word boot sector
- Two 8K-byte/4K-word sectors
- One 32K-byte/16K-word sector
- Seven 64K-byte/32K-word sectors

Any combination of sectors can be marked as read-only or erased. Full-chip erasure is also supported.

Sector data protection is afforded by methods that can disable any combination of sectors from write or read operations using standard programming equipment. An on-chip state machine provides an on-board algorithm that automatically pre-programs and erases any sector before it automatically programs and verifies program data at any specified address. The command set is compatible with that of the Joint Electronic Device Engineering Council (JEDEC) standards and is compatible with the JEDEC 4M-bit electrically erasable, programmable read-only memory (EEPROM) command set. A suspend/resume feature allows access to unaltered memory blocks during a section-erase operation. All outputs of this device are TTL-compatible. Additionally, an erase/suspend/resume feature supports reading data from, or programming data to, a sector that is not being erased.



description (continued)

48-PIN TSOP
 DCD PACKAGE
 (TOP VIEW)



Device operations are selected by writing JEDEC-standard commands into the command register using standard microprocessor write timings. The command register acts as an input to an internal-state machine which interprets the commands, controls the erase and programming operations, outputs the status of the device, outputs the data stored in the device, and outputs the device algorithm-selection code. On initial power up, the device defaults to the read mode. A hardware-reset pin initializes the internal-state machine to the read operation.

The device has low power dissipation with a 40-mA active read for the byte mode, 50-mA active read for the word mode, 60-mA typical program/erase current mode, and less than 100- μ A standby current with a 5- μ A deep-power-down mode. These devices are offered with 80-, 90-, 100-, and 120-ns access times. Table 1 and Table 2 show the sector-address ranges. The TMS29F400T/B is offered in a 44-pin plastic small-outline package (PSOP) (DBJ suffix) and a 48-pin thin small-outline package (TSOP) (DCD suffix).

PRODUCT PREVIEW



TMS29F400T, TMS29F400B 524288 BY 8-BIT/262144 BY 16-BIT FLASH MEMORIES

SMJS843A – MAY 1997 – REVISED SEPTEMBER 1997

device symbol nomenclature

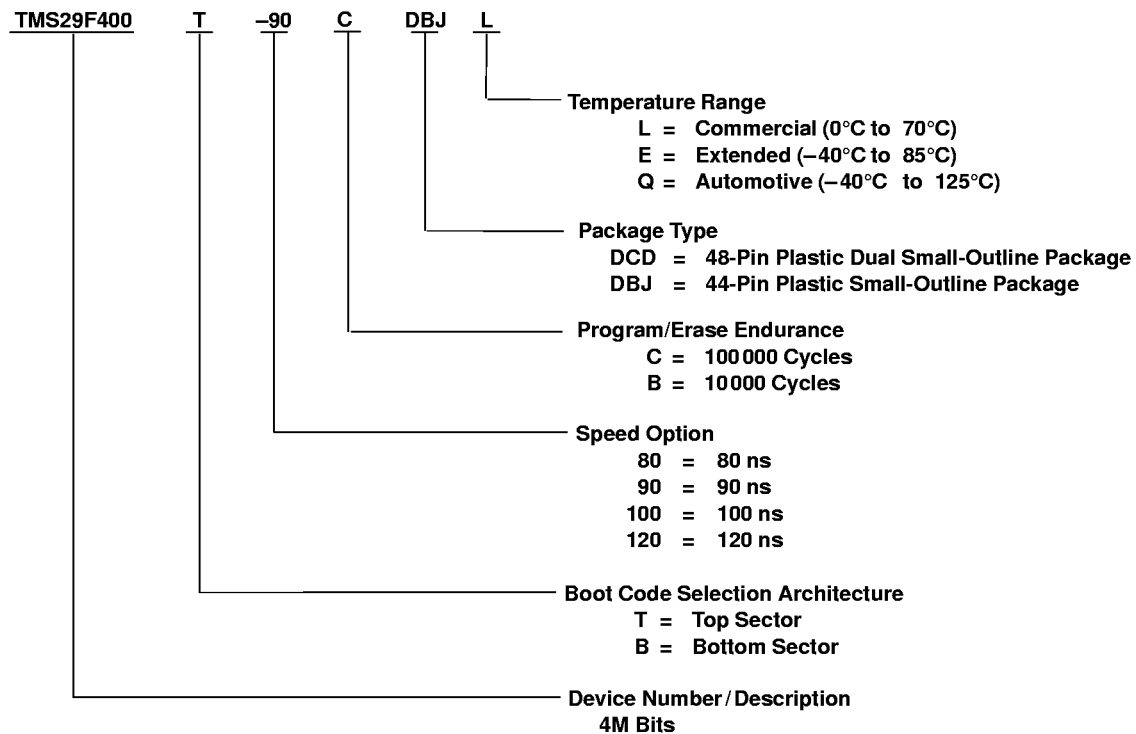

PRODUCT PREVIEW



logic symbol for 44-pin package†

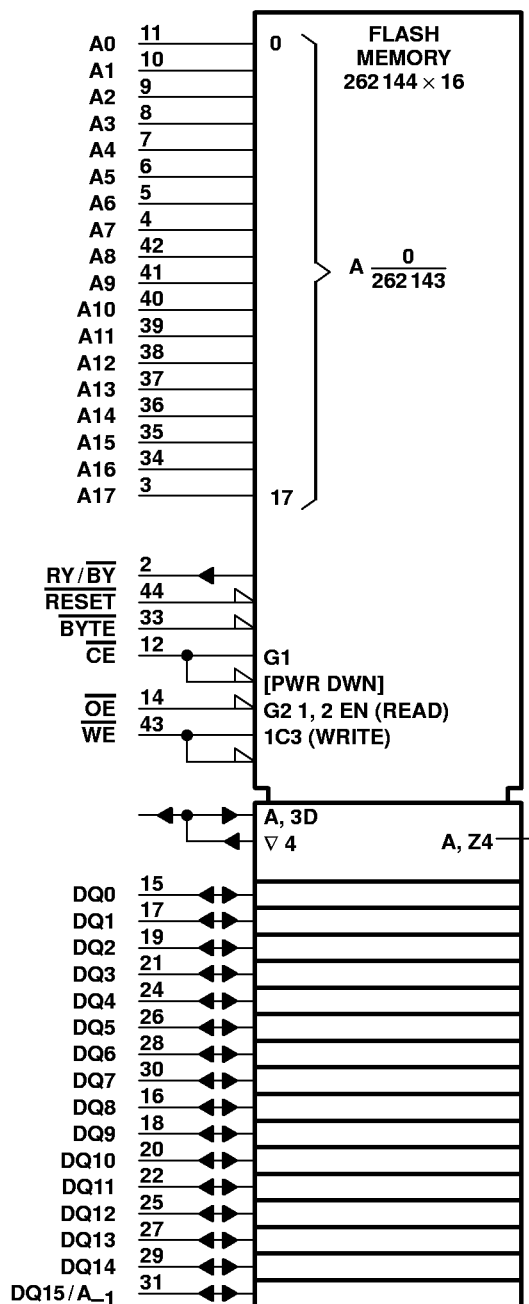

PRODUCT PREVIEW

† This symbol is in accordance with ANSI/IEEE Std 91-1984 and IEC Publication 617-12.
 Pin numbers shown are for the DBJ package.



TMS29F400T, TMS29F400B
524288 BY 8-BIT/262144 BY 16-BIT
FLASH MEMORIES

SMJS843A – MAY 1997 – REVISED SEPTEMBER 1997

logic symbol for 48-pin package†

PRODUCT PREVIEW

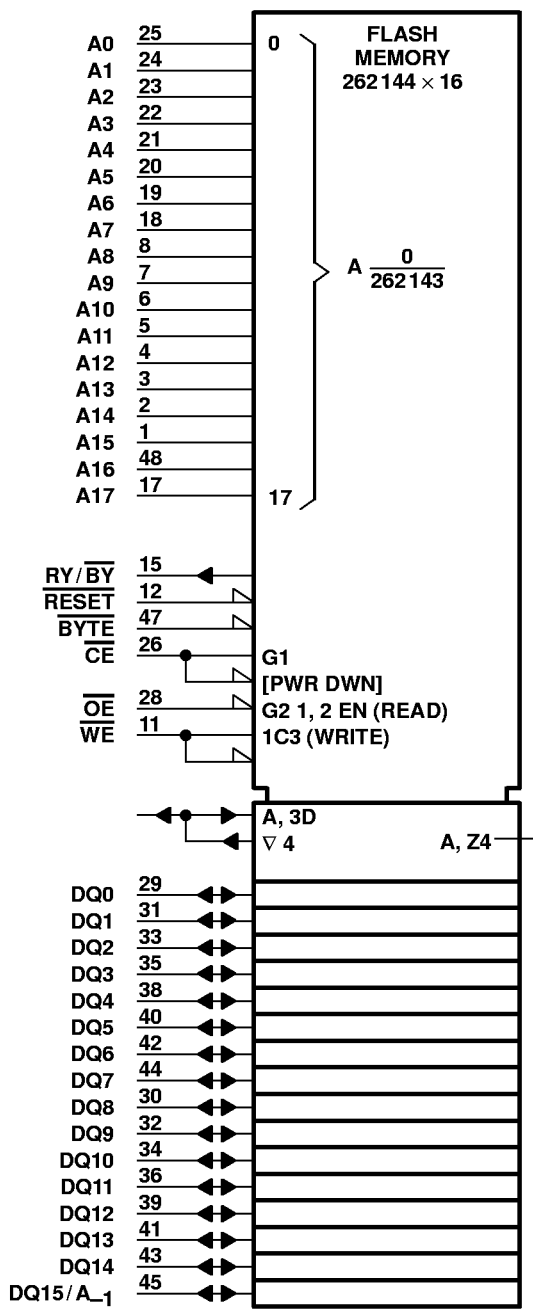

† This symbol is in accordance with ANSI/IEEE Std 91-1984 and IEC Publication 617-12.
 Pin numbers shown are for the DCD package.



block diagram

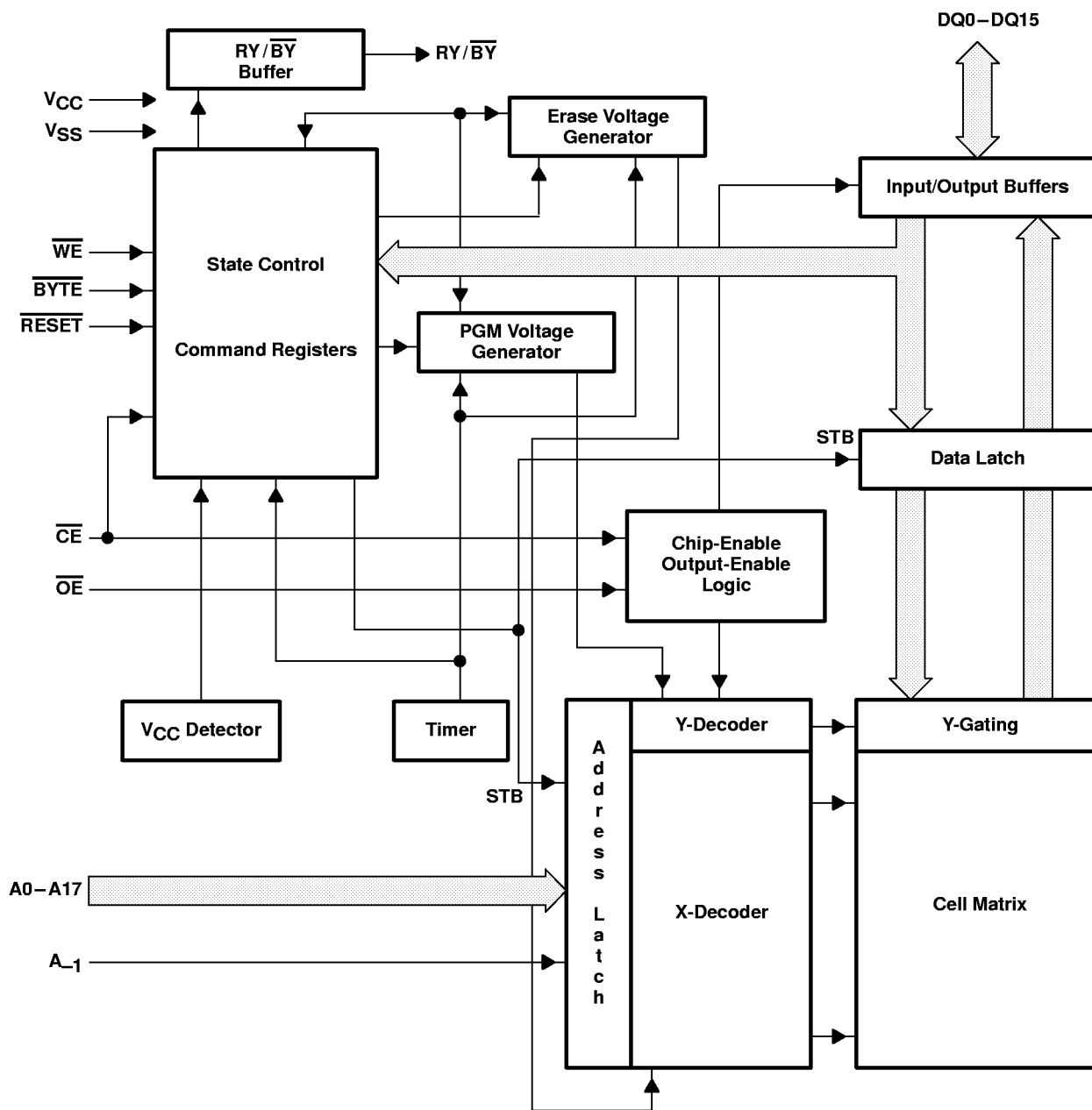

PRODUCT PREVIEW



TMS29F400T, TMS29F400B
524288 BY 8-BIT/262144 BY 16-BIT
FLASH MEMORIES

SMJS843A – MAY 1997 – REVISED SEPTEMBER 1997

operation

See Table 1 and Table 2 for the sector-address ranges of the TMS29F400T/B.

Table 1. Top-Boot Sector-Address Ranges†

	A17	A16	A15	A14	A13	A12	SECTOR SIZE	(x8) ADDRESS RANGE	(x16) ADDRESS RANGE
SA10	1	1	1	1	1	X	16K Byte	7C000H–7FFFFH	3E000H–3FFFFH
SA9	1	1	1	1	0	1	8K Byte	7A000H–7BFFFH	3D000H–3DFFFH
SA8	1	1	1	1	0	0	8K Byte	78000H–79FFFH	3C000H–3CFFFH
SA7	1	1	1	0	X	X	32K Byte	70000H–77FFFH	38000H–3BFFFH
SA6	1	1	0	X	X	X	64K Byte	60000H–6FFFFH	30000H–37FFFH
SA5	1	0	1	X	X	X	64K Byte	50000H–5FFFFH	28000H–2FFFFH
SA4	1	0	0	X	X	X	64K Byte	40000H–4FFFFH	20000H–27FFFH
SA3	0	1	1	X	X	X	64K Byte	30000H–3FFFFH	18000H–1FFFFH
SA2	0	1	0	X	X	X	64K Byte	20000H–2FFFFH	10000H–17FFFH
SA1	0	0	1	X	X	X	64K Byte	10000H–1FFFFH	08000H–0FFFFH
SA0	0	0	0	X	X	X	64K Byte	00000H–0FFFFH	00000H–07FFFH

† The address range is A₁–A17 in byte mode.
 The address range is A0–A17 in word mode.

Table 2. Bottom-Boot Sector-Address Ranges†

	A17	A16	A15	A14	A13	A12	SECTOR SIZE	(x8) ADDRESS RANGE	(x16) ADDRESS RANGE
SA10	1	1	1	X	X	X	64K Byte	70000H–7FFFFH	38000H–3FFFFH
SA9	1	1	0	X	X	X	64K Byte	60000H–6FFFFH	30000H–37FFFH
SA8	1	0	1	X	X	X	64K Byte	50000H–5FFFFH	28000H–2FFFFH
SA7	1	0	0	X	X	X	64K Byte	40000H–4FFFFH	20000H–27FFFH
SA6	0	1	1	X	X	X	64K Byte	30000H–3FFFFH	18000H–1FFFFH
SA5	0	1	0	X	X	X	64K Byte	20000H–2FFFFH	10000H–17FFFH
SA4	0	0	1	X	X	X	64K Byte	10000H–1FFFFH	08000H–0FFFFH
SA3	0	0	0	1	X	X	32K Byte	08000H–0FFFFH	04000H–07FFFH
SA2	0	0	0	0	1	1	8K Byte	06000H–07FFFH	03000H–03FFFH
SA1	0	0	0	0	1	0	8K Byte	04000H–05FFFH	02000H–02FFFH
SA0	0	0	0	0	0	X	16K Byte	00000H–03FFFH	00000H–01FFFH

† The address range is A₁–A17 in byte mode.
 The address range is A0–A17 in word mode.

PRODUCT PREVIEW



operation (continued)

See Table 3 and Table 4 for the operation modes of the TMS29F400T/B.

Table 3. Byte-Operation Mode ($\overline{\text{BYTE}} = V_{\text{IL}}$)

MODE	FUNCTIONS†								DQ0–DQ7
	$\overline{\text{CE}}$	$\overline{\text{OE}}$	$\overline{\text{WE}}$	A0	A1	A6	A9	$\overline{\text{RESET}}$	
Algorithm-selection mode	V_{IL}	V_{IL}	V_{IH}	V_{IL}	V_{IL}	V_{IL}	V_{ID}	V_{IH}	Manufacturer-Equivalent Code 01h (TMS29F400 – Byte)
5-V power supply	V_{IL}	V_{IL}	V_{IH}	V_{IH}	V_{IL}	V_{IL}	V_{ID}	V_{IH}	Device-Equivalent Code 23h (TMS29F400T – Byte)
	V_{IL}	V_{IL}	V_{IH}	V_{IH}	V_{IL}	V_{IL}	V_{ID}	V_{IH}	Device-Equivalent Code ABh (TMS29F400B – Byte)
Read	V_{IL}	V_{IL}	V_{IH}	A0	A1	A6	A9	V_{IH}	Data out
Output disable	V_{IL}	V_{IH}	V_{IH}	X	X	X	X	V_{IH}	Hi-Z
Standby and write inhibit	V_{IH}	X	X	X	X	X	X	V_{IH}	Hi-Z
Write‡	V_{IL}	V_{IH}	V_{IL}	A0	A1	A6	A9	V_{IH}	Data in
Temporary sector unprotect	X	X	X	X	X	X	X	V_{ID}	X
Verify sector protect	V_{IL}	V_{IL}	V_{IH}	V_{IL}	V_{IH}	V_{IL}	V_{ID}	V_{IH}	Data out
Hardware reset	X	X	X	X	X	X	X	V_{IL}	Hi-Z

Legend:

V_{IL} = Logic 0

V_{IH} = Logic 1

V_{ID} = 12.0 ± 0.5 V

† X can be V_{IL} or V_{IH} .

‡ See Table 6 for valid address and data during write.

Table 4. Word-Operation Mode ($\overline{\text{BYTE}} = V_{\text{IH}}$)

MODE	FUNCTIONS†								DQ0–DQ15
	$\overline{\text{CE}}$	$\overline{\text{OE}}$	$\overline{\text{WE}}$	A0	A1	A6	A9	$\overline{\text{RESET}}$	
Algorithm-selection mode	V_{IL}	V_{IL}	V_{IH}	V_{IL}	V_{IL}	V_{IL}	V_{ID}	V_{IH}	Manufacturer-Equivalent Code 01h (TMS29F400 – Word)
5-V power supply	V_{IL}	V_{IL}	V_{IH}	V_{IH}	V_{IL}	V_{IL}	V_{ID}	V_{IH}	Device-Equivalent Code 2223h (TMS29F400T – Word)
	V_{IL}	V_{IL}	V_{IH}	V_{IH}	V_{IL}	V_{IL}	V_{ID}	V_{IH}	Device-Equivalent Code 22ABh (TMS29F400B – Word)
Read	V_{IL}	V_{IL}	V_{IH}	A0	A1	A6	A9	V_{IH}	Data out
Output disable	V_{IL}	V_{IH}	V_{IH}	X	X	X	X	V_{IH}	Hi-Z
Standby and write inhibit	V_{IH}	X	X	X	X	X	X	V_{IH}	Hi-Z
Write‡	V_{IL}	V_{IH}	V_{IL}	A0	A1	A6	A9	V_{IH}	Data in
Temporary sector unprotect	X	X	X	X	X	X	X	V_{ID}	X
Verify sector protect	V_{IL}	V_{IL}	V_{IH}	V_{IL}	V_{IH}	V_{IL}	V_{ID}	V_{IH}	Data out
Hardware reset	X	X	X	X	X	X	X	V_{IL}	Hi-Z

Legend:

V_{IL} = Logic 0

V_{IH} = Logic 1

V_{ID} = 12.0 ± 0.5 V

† X can be V_{IL} or V_{IH} .

‡ See Table 6 for valid address and data during write.



TMS29F400T, TMS29F400B

524288 BY 8-BIT/262144 BY 16-BIT

FLASH MEMORIES

SMJS843A – MAY 1997 – REVISED SEPTEMBER 1997

read mode

A logic-low signal applied to the \overline{CE} and \overline{OE} pins allows the output of the TMS29F400T/B to be read. When two or more '29F400T/B devices are connected in parallel, the output of any one device can be read without interference. The \overline{CE} pin is for power control and must be used for device selection. The \overline{OE} pin is for output control, and is used to gate the data output onto the bus from the selected device.

The address-access time (t_{AVQV}) is the delay from stable address to valid output data. The chip-enable (\overline{CE}) access time (t_{ELQV}) is the delay from \overline{CE} low and stable addresses to valid output data. The output-enable access time (t_{GLQV}) is the delay from \overline{OE} low to valid output data when \overline{CE} equals logic low, and addresses are stable for at least the duration of $t_{AVQV} - t_{GLQV}$.

standby mode

I_{CC} supply current is reduced by applying a logic-high level on \overline{CE} and \overline{RESET} to enter the standby mode. In the standby mode, the outputs are placed in the high-impedance state. Applying a CMOS logic-high level on \overline{CE} and \overline{RESET} reduces the current to 100 μ A. Applying a TTL logic-high level on \overline{CE} and \overline{RESET} reduces the current to 1 mA. If the '29F400T/B is deselected during erasure or programming, the device continues to draw active current until the operation is complete.

output disable

When \overline{OE} equals V_{IH} or \overline{CE} equals V_{IH} , output from the device is disabled and the output pins (DQ0–DQ15) are placed in the high-impedance state.

automatic-sleep mode

The '29F400 has a built-in feature called automatic-sleep mode to minimize device energy consumption which is independent of \overline{CE} , \overline{WE} , and \overline{OE} , and is enabled when addresses remain stable for 300 ns. Typical sleep-mode current is 100 μ A. Sleep mode does not affect output data, which remains latched and available to the system.

algorithm selection

The algorithm-selection mode provides access to a binary code that matches the device with its proper programming and erase command operations. This mode is activated when V_{ID} (11.5 V to 12.5 V) is placed on address pin A9. Address pins A1 and A6 must be logic low. Two bytes of code are accessed by toggling address pin A0 from V_{IL} to V_{IH} . Address pins other than A0, A1, and A6 can be at logic low or at logic high.

The algorithm-selection mode can also be read by using the command register, which is useful when V_{ID} is not available to be placed on address pin A9. Table 5 shows the binary algorithm-selection codes.

Table 5. Algorithm-Selection Codes (5-V Single Power Supply)[†]

	CODE	DQ15	DQ14	DQ13	DQ12	DQ11	DQ10	DQ9	DQ8	DQ7	DQ6	DQ5	DQ4	DQ3	DQ2	DQ1	DQ0
Manufacturer-equivalent code	01H	0	0	0	0	0	0	0	0	0	0	0	0	0	0	0	1
TMS29F400T—byte	23H	A ₋₁	Hi-Z	Hi-Z	Hi-Z	Hi-Z	Hi-Z	Hi-Z	Hi-Z	0	0	1	0	0	0	1	1
TMS29F400B—byte	ABH	A ₋₁	Hi-Z	Hi-Z	Hi-Z	Hi-Z	Hi-Z	Hi-Z	Hi-Z	1	0	1	0	1	0	1	1
TMS29F400T	2223H	0	0	1	0	0	0	1	0	0	0	1	0	0	0	1	1
TMS29F400B	22ABH	0	0	1	0	0	0	1	0	1	0	1	0	1	0	1	1
Sector protection	01H	0	0	0	0	0	0	0	0	0	0	0	0	0	0	0	1

[†] A1 = V_{IL} , A6 = V_{IL} , \overline{CE} = V_{IL} , \overline{OE} = V_{IL}

PRODUCT PREVIEW



erasure and programming

Erasure and programming of the '29F400 are accomplished by writing a sequence of commands using standard microprocessor write timing. The commands are written to a command register and input to the command-state machine (CSM). The CSM interprets the command entered and initiates program, erase, suspend, and resume operations as instructed. The CSM acts as the interface between the write-state machine (WSM) and external-chip operations. The WSM controls all voltage generation, pulse generation, preconditioning, and verification of memory contents. Program and block-/chip-erase functions are fully automatic. Once the end of a program or erase operation has been reached, the device resets internally to the read mode. If V_{CC} drops below the low-voltage-detect level (V_{LKO}), any programming or erase operation is aborted and subsequent writes are ignored until the V_{CC} level is greater than V_{LKO} . The control pins must be logically correct to prevent unintentional command writes or programming or erasing.

command definitions

Device operating modes are selected by writing specific address and data sequences into the command register. Table 6 defines the valid command sequences. Writing incorrect address and data values or writing them in the incorrect sequence causes the device to reset to the read mode. The command register does not occupy an addressable memory location. The register is used to store the command sequence, along with the address and data needed by the memory array. Commands are written by setting $\overline{CE} = V_{IL}$, $\overline{OE} = V_{IH}$, and bringing \overline{WE} from logic high to logic low. Addresses are latched on the falling edge of \overline{WE} and data is latched on the rising edge of \overline{WE} . Holding $\overline{WE} = V_{IL}$ and toggling \overline{CE} is an alternative method. See the switching characteristics of the write/erase/program-operations section for specific timing information.



TMS29F400T, TMS29F400B
524288 BY 8-BIT/262144 BY 16-BIT
FLASH MEMORIES

SMJS843A – MAY 1997 – REVISED SEPTEMBER 1997

command definitions (continued)

Table 6. Command Definitions

COMMAND	BUS CYCLES	1ST CYCLE		2ND CYCLE		3RD CYCLE		4TH CYCLE		5TH CYCLE		6TH CYCLE	
		ADDR	DATA	ADDR	DATA	ADDR	DATA	ADDR	DATA	ADDR	DATA	ADDR	DATA
Read/reset (word)	1	xxxxH	xxF0H										
Read/reset (byte)	1	xxx	F0H										
Read/reset (word)	3	555H	xxAAH	2AAH	xx55H	555H	xxF0H	RA	RD				
Read/reset (byte)	3	2AAH	AAH	555H	55H	2AAH	F0H	RA	RD				
Algorithm selection (word)	3	555H	xxAAH	2AAH	xx55H	555H	xx90H	01H	2223H				
									T				
Algorithm selection (byte)	3	2AAH	AAH	555H	55H	2AAH	90H	01H	22ABH				
									B				
Program (word)	4	555H	xxAAH	2AAH	xx55H	555H	xxA0H	PA	23H				
									T				
Program (byte)	4	2AAH	AAH	555H	55H	2AAH	A0H	PA	ABH				
									B				
Chip erase (word)	6	555H	xxAAH	2AAH	xx55H	555H	xx80H	555H	xxAAH	2AAH	xx55H	555H	xx10H
Chip erase (byte)	6	2AAH	AAH	555H	55H	2AAH	80H	2AAH	AAH	555H	55H	2AAH	10H
Sector erase (word)	6	555H	xxAAH	2AAH	xx55H	555H	xx80H	555H	xxAAH	2AAH	xx55H	SA	xx30H
Sector erase (byte)	6	2AAH	AAH	555H	55H	2AAH	80H	2AAH	AAH	555H	55H	SA	30H
Sector-erase suspend (word)	1	XXXXH	xxB0H	Erase suspend valid during sector-erase operation									
Sector-erase suspend (byte)	1	XXX	B0H	Erase suspend valid during sector-erase operation									
Sector-erase resume (word)	1	XXXXH	xx30H	Erase resume valid only after erase-suspend operation									
Sector-erase resume (byte)	1	XXX	30H	Erase resume valid only after erase-suspend operation									

LEGEND:

- RA = Address of the location to be read
- PA = Address of the location to be programmed
- SA = Address of the sector to be erased
Addresses A12–A17 select 1 to 11 sectors.
- RD = Data to be read at selected address location
- PD = Data to be programmed at selected address location

read/reset command

The read or reset mode is activated by writing either of the two read/reset command sequences into the command register. The device remains in this mode until another valid command sequence is input in the command register. Memory data is available in the read mode and can be read with standard microprocessor read-cycle timing.

PRODUCT PREVIEW



read/reset command (continued)

On power up, the device defaults to the read/reset mode. A read/reset command sequence is not required and memory data is available.

algorithm-selection command

The algorithm-selection command allows access to a binary code that matches the device with the proper programming and erase command operations. After writing the three-bus-cycle command sequence, the first byte of the algorithm-selection code can be read from address XX00h. The second byte of the code can be read from address XX01h (see Table 6). This mode remains in effect until another valid command sequence is written to the device.

program command

Programming is a four-bus-cycle command sequence. The first three bus cycles put the device into the program-setup state. The fourth bus cycle loads the address location and the data to be programmed into the device. The addresses are latched on the falling edge of \overline{WE} and the data is latched on the rising edge of \overline{WE} in the fourth bus cycle. The rising edge of \overline{WE} starts the program operation. The embedded programming function automatically provides needed voltage and timing to program and verify the cell margin. Any further commands written to the device during the program operation are ignored.

Programming can be performed at any address location in any sequence. When erased, all bits are in a logic-high state. Logic lows are programmed into the device and only an erase operation can change bits from logic lows to logic highs. Attempting to program a 1 into a bit that has been programmed previously to a 0 causes the internal-pulse counter to exceed the pulse-count limit, which sets the exceed-time-limit indicator (DQ5) to a logic-high state. The automatic-programming operation is complete when the data on DQ7 is equivalent to the data written to this bit, at which time the device returns to the read mode and addresses are no longer latched. Figure 9 shows a flowchart of the typical device-programming operation.

chip-erase command

Chip erase is a six-bus-cycle command sequence. The first three bus cycles put the device into the erase-setup state. The next two bus cycles unlock the erase mode. The sixth bus cycle loads the chip-erase command. This command sequence is required to ensure that the memory contents are not erased accidentally. The rising edge of \overline{WE} starts the chip-erase operation. Any further commands written to the device during the chip-erase operation are ignored.

The embedded chip-erase function automatically provides voltage and timing needed to program and to verify all the memory cells prior to electrical erase. It then erases and verifies the cell margin automatically without programming the memory cells prior to erase.

Figure 12 shows a flowchart of the typical chip-erase operation.

sector-erase command

Sector-erase is a six-bus-cycle command sequence. The first three bus cycles put the device into the erase-setup state. The next two bus cycles unlock the erase mode and then the sixth bus cycle loads the sector-erase command and the sector-address location to be erased. Any address location within the desired sector can be used. The addresses are latched on the falling edge of \overline{WE} and the sector-erase command (30h) is latched on the rising edge of \overline{WE} in the sixth bus cycle. After a delay of 80 μ s from the rising edge of \overline{WE} , the sector-erase operation begins on the selected sector(s).

Additional sectors can be selected to be erased concurrently during the sector-erase command sequence. For each additional sector to be selected for erase, another bus cycle is issued. The bus cycle loads the next sector-address location and the sector-erase command. The time between the end of the previous bus cycle and the start of the next bus cycle must be less than 100 μ s; otherwise, the new sector location is not loaded. A time delay of 100 μ s from the rising edge of the last \overline{WE} starts the sector-erase operation. If there is a falling edge of \overline{WE} within the 100 μ s time delay, the timer is reset.



TMS29F400T, TMS29F400B 524288 BY 8-BIT/262144 BY 16-BIT FLASH MEMORIES

SMJS843A – MAY 1997 – REVISED SEPTEMBER 1997

sector-erase command (continued)

One to eleven sector-address locations can be loaded in any sequence. The state of the delay timer can be monitored using the sector-erase delay indicator (DQ3). If DQ3 is at logic low, the time delay has not expired. See the operation status section for a description.

Any command other than erase suspend (B0h) or sector erase (30h) written to the device during the sector-erase operation causes the device to exit the sector-erase mode and the contents of the sector(s) selected for erase are no longer valid. To complete the sector-erase operation, re-issue the sector-erase command sequence.

The embedded sector-erase function automatically provides needed voltage and timing to program and to verify all of the memory cells prior to electrical erase and then erases and verifies the cell margin automatically. Programming the memory cells prior to erase is not required.

See the operation status section for a full description. Figure 14 shows a flowchart of the typical sector-erase operation.

erase-suspend command

The erase-suspend command (B0h) allows interruption of a sector-erase operation to read data from unaltered sectors of the device. Erase-suspend is a one-bus-cycle command. The addresses can be V_{IL} or V_{IH} and the erase-suspend command (B0h) is latched on the rising edge of \overline{WE} . Once the sector-erase operation is in progress, the erase-suspend command requests the internal write-state machine to halt operation at predetermined breakpoints. The erase-suspend command is valid only during the sector-erase operation and is invalid during programming and chip-erase operations. The sector-erase delay timer expires immediately if the erase-suspend command is issued while the delay is active.

After the erase-suspend command is issued, the device takes between 0.1 μ s and 15 μ s to suspend the operation. The toggle bit must be monitored to determine when the suspend has been executed. When the toggle bit stops toggling, data can be read from sectors that are not selected for erase. Reading from a sector selected for erase can result in invalid data. See the operation status section for a full description.

Once the sector-erase operation is suspended, reading from or programming to a sector that is not being erased can be performed. This command is applicable only during sector-erase operations. Any other command written during erase-suspend mode to the suspended sector is ignored.

erase-resume command

The erase-resume command (30h) restarts a suspended sector-erase operation from the point where it was halted. Erase resume is a one-bus-cycle command. The addresses can be V_{IL} or V_{IH} and the erase-resume command (30h) is latched on the rising edge of \overline{WE} . When an erase-suspend/erase-resume command combination is written, the internal-pulse counter (exceed timing limit) is reset. The erase-resume command is valid only in the erase-suspend state. After the erase-resume command is executed, the device returns to the valid sector-erase state and further writes of the erase-resume command are ignored. After the device has resumed the sector-erase operation, another erase-suspend command can be issued to the device.

operation status

The status of the device during an automatic-programming algorithm, chip-erase, or automatic-erase algorithm can be determined in three ways:

- DQ7: Data polling
- DQ6: Toggle bit
- RY/ \overline{BY} : Ready/busy bit

PRODUCT PREVIEW



POST OFFICE BOX 655303 • DALLAS, TEXAS 75265
POST OFFICE BOX 1443 • HOUSTON, TEXAS 77251-1443

status-bit definitions

During operation of the automatic embedded program and erase functions, the status of the device can be determined by reading the data state of designated outputs. The data-polling bit (DQ7) and toggle bit (DQ6) require multiple successive reads to observe a change in the state of the designated output. Table 7 defines the values of the status flags.

Table 7. Operation Status Flags†

	DEVICE OPERATION‡	DQ7	DQ6	DQ5	DQ3	DQ2	RY/BY	
In progress	Programming	$\overline{DQ7}$	T	0	0	No Tog	0	
	Program/erase in auto-erase	0	T	0	1	§	0	
	Erase-suspend mode	Erase-sector address	1	No Tog	0	0	T	1
		Non-erase sector address	D	D	D	D	D	1
	Program in erase suspend	$\overline{DQ7}$ ¶	T	0	0	1§	0	
Exceeded time limits	Programming	$\overline{DQ7}$	T	1	0	No Tog	0	
	Program/erase in auto erase	0	T	1	1	#	0	
	Program in erase suspend	$\overline{DQ7}$	T	1	0	No Tog	0	
Successful operation complete	Programming complete	D	D	D	D	D	1	
	Sector-/chip-erase complete	1	1	1	1	1	1	

† T= toggle, D= data, No Tog= No toggle

‡ DQ4, DQ1, DQ0 are reserved for future use.

§ DQ2 can be toggled when the sector address applied is an erasing sector. DQ2 cannot be toggled when the sector address applied is a non-erasing sector. DQ2 is used to determine which sectors are erasing and which are not.

¶ Status flags apply when outputs are read from the address of a non-erase-suspend operation.

If DQ5 is high (exceeded timing limits), successive reads from a problem sector causes DQ2 to toggle.

data-polling (DQ7)

The data-polling-status function outputs the complement of the data latched into the DQ7 data register while the write-state machine is engaged in a program or erase operation. The changing of data bit DQ7 from complement to true indicates the end of an operation. Data-polling is available only during programming, chip-erase, sector-erase, and sector-erase-timing delay. Data-polling is valid after the rising edge of \overline{WE} in the last bus cycle of the command sequence loaded into the command register. Figure 16 shows a flowchart for data-polling.

During a program operation, reading DQ7 outputs the complement of the DQ7 data to be programmed at the selected address location. Upon completion, reading DQ7 outputs the true DQ7 data loaded into the program-data register. During the erase operations, reading DQ7 outputs a logic low. Upon completion, reading DQ7 outputs a logic high. Also, data-polling must be performed at a sector address that is within a sector that is being erased. Otherwise, the status is invalid. When using data-polling, the address should remain stable throughout the operation.

During a data-polling read, while \overline{OE} is logic low, data bit DQ7 can change asynchronously. Depending on the read timing, the system can read valid data on DQ7, while other DQ pins are still invalid. A subsequent read of the device is valid. See Figure 17 for the data-polling timing diagram.



TMS29F400T, TMS29F400B 524288 BY 8-BIT/262144 BY 16-BIT FLASH MEMORIES

SMJS843A – MAY 1997 – REVISED SEPTEMBER 1997

toggle-bit (DQ6)

The toggle-bit status function outputs data on DQ6, which toggles between logic high and logic low while the write-state machine is engaged in a program or erase operation. When DQ6 stops toggling after two consecutive reads to the same address, the operation is complete. The toggle bit is available only during programming, chip erase, sector erase, and sector-erase-timing delay. Toggle-bit data is valid after the rising edge of \overline{WE} in the last bus cycle of the command sequence loaded into the command register. Figure 18 shows a flowchart of the toggle-bit status-read algorithm. Depending on the read timing, DQ6 can stop toggling while other DQ pins are still invalid and a subsequent read of the device is valid. See Figure 19 for the toggle-bit timing diagram.

exceed time limit (DQ5)

The program and erase operations use an internal-pulse counter to limit the number of pulses applied. If the pulse-count limit is exceeded, DQ5 is set to a logic-high data state. This indicates that the program or erase operation has failed. DQ7 does not change from complemented data to true data and DQ6 does not stop toggling when read. To continue operation, the device must be reset.

The exceed-time-limit condition occurs when attempting to program a logic-high state into a bit that has been programmed previously to a logic low. Only an erase operation can change bits from logic low to logic high. After reset, the device is functional and can be erased and reprogrammed.

sector-load-timer (DQ3)

The sector-load-timer status bit, DQ3, is used to determine whether the time to load additional sector addresses has expired. After completion of a sector-erase command sequence, DQ3 remains at a logic low for 100 μ s. This indicates that another sector-erase command sequence can be issued. If DQ3 is at a logic high, it indicates that the delay has expired and attempts to issue additional sector-erase commands are ignored. See the sector-erase command section for a description.

The data-polling and toggle bit are valid during the 100- μ s time delay and can be used to determine if a valid sector-erase command has been issued. To ensure additional sector-erase commands have been accepted, the status of DQ3 should be read before and after each additional sector-erase command. If DQ3 is at a logic low on both reads, the additional sector-erase command was accepted.

toggle bit 2 (DQ2)

The state of DQ2 determines whether the device is in algorithmic-erase mode or erase-suspend mode. DQ2 toggles if successive reads are issued to the erasing or erase-suspended sector, assuming in case of the latter that the device is in erase-suspend-read mode. It also toggles when DQ5 becomes a logic high due to the timer-exceed limit, and reads are issued to the failed sector. DQ2 does not toggle in any other sector due to DQ5 failure. When the device is in erase-suspend-program mode, successive reads from the non-erase-suspended sector causes a logic high on DQ2.

ready/busy bit (RY/ \overline{BY})

The RY/ \overline{BY} bit indicates when the device can accept new commands after performing algorithmic operations. If the RY/ \overline{BY} (open-drain output) bit is low, the device is busy with either a program or erase operation and does not accept any other commands except for erase suspend. While it is in the erase-suspend mode, RY/ \overline{BY} remains high. In program mode, the RY/ \overline{BY} bit is valid (logic low) after the fourth \overline{WE} pulse. In erase mode, it is valid after the sixth \overline{WE} pulse. There is a delay period t_{busy} , after which the RY/ \overline{BY} bit becomes valid. See Figure 28 for the timing waveform.

Since the RY/ \overline{BY} bit is an open-drain output, several such bits can be combined in parallel with a pullup resistor to V_{CC} .



hardware-reset bit ($\overline{\text{RESET}}$)

When the $\overline{\text{RESET}}$ pin is driven to a logic low, it forces the device out of the currently active mode and into a reset state. It also avoids bus contention by placing the outputs into the high-impedance state for the duration of the $\overline{\text{RESET}}$ pulse.

During program or erase operation, if $\overline{\text{RESET}}$ is asserted to logic low, the RY/ $\overline{\text{BY}}$ bit remains at logic low until the reset operation is complete. Since this can take anywhere from 1 μs to 20 μs , the RY/ $\overline{\text{BY}}$ bit can be used to sense reset completion or the user can allow a maximum of 20 μs . If $\overline{\text{RESET}}$ is asserted during read mode, then the reset operation is complete within 500 ns. See Figure 1 and Figure 2 for timing specifications.

The $\overline{\text{RESET}}$ pin also can be used to drive the device into deep power-down (standby) mode by applying $V_{\text{SS}} \pm 0.3 \text{ V}$ to it. I_{CC4} reads $<1 \mu\text{A}$ typical, and 5 μA maximum for CMOS inputs. Standby mode can be entered anytime, regardless of the condition of $\overline{\text{CE}}$.

Asserting $\overline{\text{RESET}}$ during program or erase can leave erroneous data in the address locations. These locations need to be updated after the device resumes normal operations. A minimum of 50 ns must be allowed after $\overline{\text{RESET}}$ goes high before a valid read can take place.

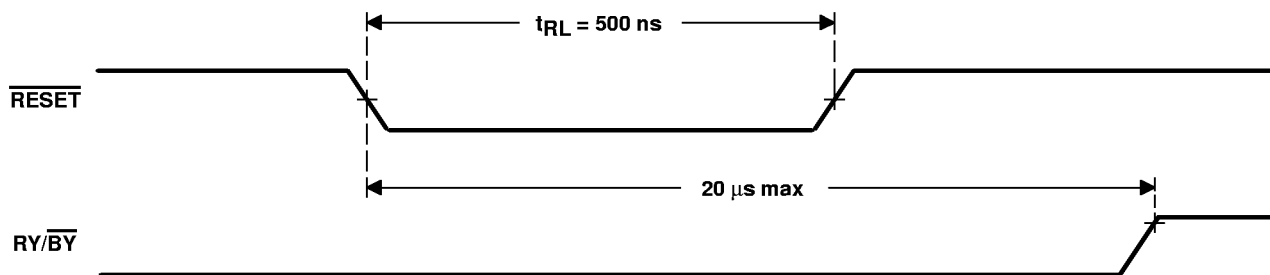

Figure 1. Device Reset During a Program or Erase Operation

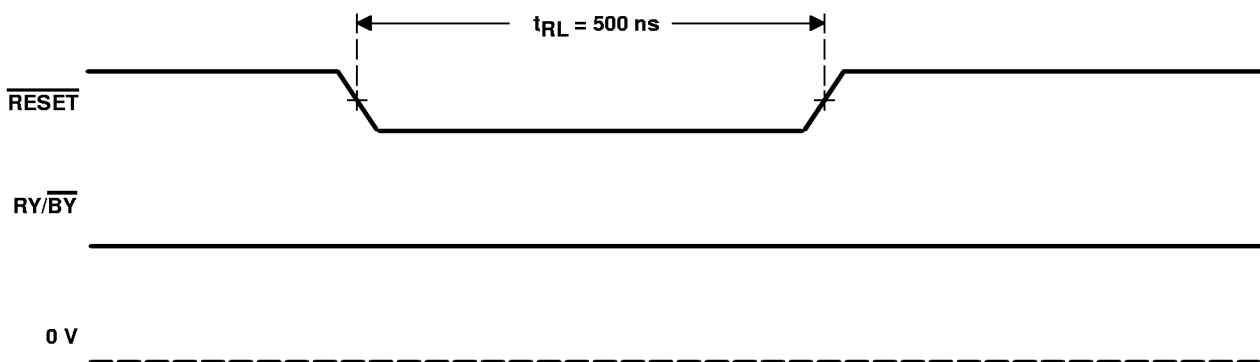

Figure 2. Device Reset During Read Mode

TMS29F400T, TMS29F400B
524288 BY 8-BIT/262144 BY 16-BIT
FLASH MEMORIES

SMJS843A – MAY 1997 – REVISED SEPTEMBER 1997

word-/byte-mode configuration

The $\overline{\text{BYTE}}$ pin is used to set the device configuration. If $\overline{\text{BYTE}}$ is at a logic 1, the device is in word mode with all data outputs valid and the DQ15/A₋₁ output representing DQ15. Similarly, if $\overline{\text{BYTE}}$ is at a logic 0, the device is in byte mode with only DQ0–DQ7 valid. The remaining outputs are in high-impedance mode and DQ15/A₋₁ is used as an input for the least significant bit (LSB) (A1) address function. See Figure 3 and Figure 4 for timing specifications.

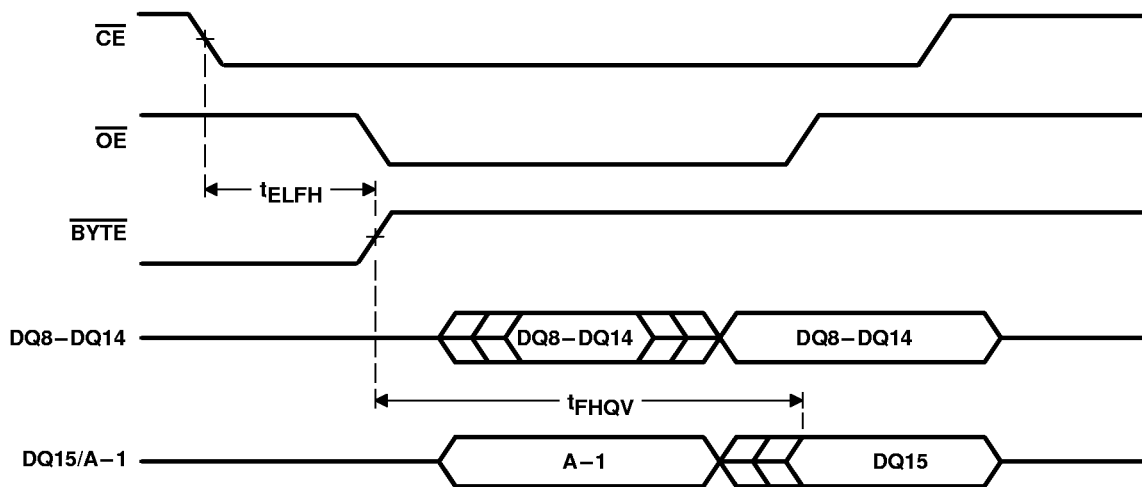

Figure 3. Word-Mode Configuration

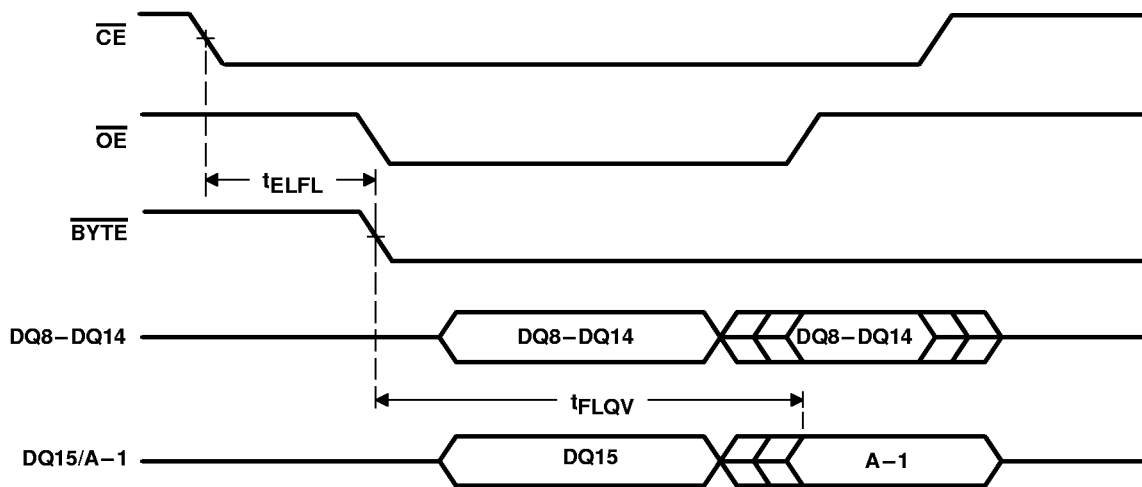

Figure 4. Byte-Mode Configuration

temporary hardware-sector unprotect feature

This feature temporarily enables both programming and erase operations on any combination of one to eleven sectors that were previously protected. This feature is enabled using high voltage V_{ID} (11.5 V to 12.5 V) on the $\overline{\text{RESET}}$ pin, using standard command sequences.

Normally, the device is delivered with all sectors unprotected.

PRODUCT PREVIEW



sector-protect programming

The sector-protect programming mode is activated when A6, A0, and \overline{CE} are at V_{IL} , and address pin A9 and control pin \overline{OE} are forced to V_{ID} . Address pin A1 is set to V_{IH} . The sector-select address pins A12 – A17 are used to select the sector to be protected. Address pins A0–A11 and I/O pins must be stable and can be either V_{IL} or V_{IH} . Once the addresses are stable, \overline{WE} is pulsed low for 100 μ s, causing programming to begin on the falling edge of \overline{WE} and to terminate on the rising edge of \overline{WE} . Figure 20 is a flowchart of the sector-protect algorithm and Figure 21 shows a timing diagram of the sector-protect operation.

Commands to program or erase a protected sector do not change the data contained in the sector. Attempts to program and erase a protected sector cause the data-polling bit (DQ7) and the toggle bit (DQ6) to operate from 2 μ s to 100 μ s and then return to valid data.

sector-protect verify

Verification of the sector-protection programming is activated when $\overline{WE} = V_{IH}$, $\overline{OE} = V_{IL}$, $\overline{CE} = V_{IL}$, and address pin A9 = V_{ID} . Address pins A0 and A6 are set to V_{IL} , and A1 is set to V_{IH} . The sector-address pins A12–A17 select the sector that is to be verified. The other addresses can be V_{IH} or V_{IL} . If the sector that was selected is protected, the DQs output 01h. If the sector is not protected, the DQs output 00h.

Sector-protect verify can also be read using the algorithm-selection command. After issuing the three-bus-cycle command sequence, the sector-protection status can be read on DQ0. Set address pins A0 = V_{IL} , A1 = V_{IH} , and A6 = V_{IL} , and then the sector address pins A12–A17 select the sector to be verified. The remaining addresses are set to V_{IL} . If the sector selected is protected, DQ0 outputs a logic-high state. If the sector selected is not protected, DQ0 outputs a logic-low state. This mode remains in effect until another valid command sequence is written to the device. Figure 20 is a flowchart of the sector-protect algorithm and Figure 21 shows a timing diagram of the sector-protect operation.

sector unprotect

Prior to sector unprotect, all sectors must be protected using the sector-protect programming mode. The sector unprotect is activated when address pin A9 and control pin \overline{OE} are forced to V_{ID} . Address pins A1 and A6 are set to V_{IH} while \overline{CE} and A0 are set to V_{IL} . The sector-select address pins A12–A17 can be V_{IL} or V_{IH} . All sectors are unprotected in parallel and once the inputs are stable, \overline{WE} is pulsed low for 10 ms, causing the unprotect operation to begin on the falling edge of \overline{WE} and to terminate on the rising edge of \overline{WE} . Figure 22 is a flowchart of the sector-unprotect algorithm and Figure 23 shows a timing diagram of the sector-unprotect operation.

sector-unprotect verify

Verification of the sector unprotect is accomplished when $\overline{WE} = V_{IH}$, $\overline{OE} = V_{IL}$, $\overline{CE} = V_{IL}$, and A9 = V_{ID} , and then select the sector to be verified. Address pins A1 and A6 are set to V_{IH} , and A0 is set to V_{IL} . The other addresses can be V_{IH} or V_{IL} . If the sector selected is protected, the DQs output 01h. If the sector is not protected, the DQs output 00h. Sector unprotect can also be read using the algorithm-selection command.

low V_{CC} write lockout

During power-up and power-down operations, write cycles are locked out for V_{CC} less than V_{LKO} . If $V_{CC} < V_{LKO}$, the command input is disabled and the device is reset to the read mode. On power up, if $\overline{CE} = V_{IL}$, $\overline{WE} = V_{IL}$, and $\overline{OE} = V_{IH}$, the device does not accept commands on the rising edge of \overline{WE} . The device automatically powers up in the read mode.

glitching

Pulses of less than 5 ns (typical) on \overline{OE} , \overline{WE} , or \overline{CE} do not issue a write cycle.

power supply considerations

Each device should have a 0.1- μ F ceramic capacitor connected between V_{CC} and V_{SS} to suppress circuit noise. Printed circuit traces to V_{CC} should be appropriate to handle the current demand and minimize inductance.



TMS29F400T, TMS29F400B
524288 BY 8-BIT/262144 BY 16-BIT
FLASH MEMORIES

SMJS843A – MAY 1997 – REVISED SEPTEMBER 1997

absolute maximum ratings over ambient temperature range (unless otherwise noted)†

Supply voltage range, V_{CC} (see Note 1)	-0.6 V to 7 V
Input voltage range: All inputs except A9, \overline{CE} , \overline{OE} (see Note 2)	-0.6 V to $V_{CC} + 1$ V
A9, \overline{CE} , \overline{OE}	-0.6 V to 13.5 V
Output voltage range (see Note 3)	-0.6 V to $V_{CC} + 1$ V
Ambient temperature range during read/erase/program, T_A		
(L)	0°C to 70°C
(E)	-40°C to 85°C
(Q)	-40°C to 125°C
Storage temperature range, T_{stg}	-65°C to 150°C

† Stresses beyond those listed under “absolute maximum ratings” may cause permanent damage to the device. These are stress ratings only, and functional operation of the device at these or any other conditions beyond those indicated under “recommended operating conditions” is not implied. Exposure to absolute-maximum-rated conditions for extended periods may affect device reliability.

- NOTES: 1. All voltage values are with respect to V_{SS} .
 2. The voltage on any input pin can undershoot to -2 V for periods less than 20 ns (see Figure 6).
 3. The voltage on any output pin can overshoot to 7 V for periods less than 20 ns (see Figure 7).

recommended operating conditions

		MIN	MAX	UNIT	
V_{CC}	Supply voltage	4.5	5.5	V	
V_{IH}	High-level dc input voltage	TTL	2	$V_{CC}+0.5$	V
		CMOS	$V_{CC}-0.5$	$V_{CC}+0.5$	
V_{IL}	Low-level dc input voltage	TTL	-0.5	0.8	V
		CMOS	-0.5	0.8	
V_{ID}	Algorithm selection and sector-protect input voltage	11.5	12.5	V	
V_{LKO}	Low V_{CC} lock-out voltage	3.2	4.2	V	
T_A	Ambient temperature	L version	0	70	°C
		E version	-40	85	
		Q version	-40	125	

PRODUCT PREVIEW



electrical characteristics over recommended ranges of supply voltage and ambient temperature

PARAMETER		TEST CONDITIONS	MIN	MAX	UNIT
V _{OH}	High-level output voltage	TTL-input level	V _{CC} = V _{CC} MIN,	I _{OH} = -2.0 mA	2.4 V
		CMOS-input level	V _{CC} = V _{CC} MIN,	I _{OH} = -100 μA	V _{CC} -0.4
		CMOS-input level	V _{CC} = V _{CC} MIN,	I _{OH} = -2.5 mA	0.85 * V _{CC}
V _{OL}	Low-level output voltage	V _{CC} = V _{CC} MIN,	I _{OL} = 5.8 mA	0.45	V
I _I	Input current (leakage)	V _{CC} = V _{CC} MAX,	V _{IN} = V _{SS} to V _{CC}	±1	μA
I _O	Output current (leakage)	V _O = V _{SS} to V _{CC} ,	$\overline{CE} = V_{IH}$	±1	μA
I _{ID}	High-voltage current (standby)	A9 or \overline{CE} or $\overline{OE} = V_{ID}$ MAX		35	μA
I _{CC1}	V _{CC} supply current (standby)	TTL-input level	$\overline{CE} = V_{IH}$, V _{CC} = V _{CC} MAX	1	mA
		CMOS-input level	$\overline{CE} = V_{CC} \pm 0.2$, V _{CC} = V _{CC} MAX	100	μA
I _{CC2}	V _{CC} supply current (see Note 4 and Note 5)	Byte	$\overline{CE} = V_{IL}$, $\overline{OE} = V_{IH}$	30	mA
		Word		50	
I _{CC3}	V _{CC} supply current (see Note 6)	$\overline{CE} = V_{IL}$, $\overline{OE} = V_{IH}$		60	mA
I _{CC4}	V _{CC} supply current (standby during reset)	V _{CC} = V _{CC} MAX, RESET = V _{SS} ± 0.3V		5	μA
I _{CC5}	Automatic sleep mode (see Note 5 and Note 7)	V _{IH} = V _{CC} ± 0.3 V, V _{IL} = V _{SS} ± 0.3 V		100	μA

- NOTES: 4. I_{CC} current in the read mode, switching at 6 MHz
5. I_{OUT} = 0 mA
6. I_{CC} current while erase or program operation is in progress
7. Automatic sleep mode is entered when addresses remain stable for 300 ns.

capacitance over recommended ranges of supply voltage and ambient temperature

PARAMETER		TEST CONDITIONS	MIN	MAX	UNIT
C _{I1}	Input capacitance (All inputs except A9, \overline{CE} , \overline{OE})	V _I = 0 V, f = 1 MHz		7.5	pF
C _{I2}	Input capacitance (A9, \overline{CE} , \overline{OE})	V _I = 0 V, f = 1 MHz		9	pF
C _O	Output capacitance	V _O = 0 V, f = 1 MHz		12	pF



PARAMETER MEASUREMENT INFORMATION

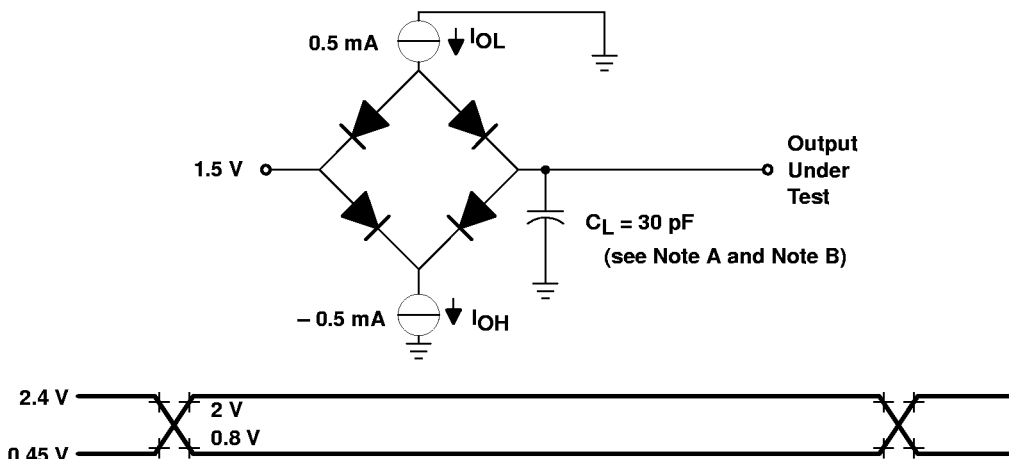

- NOTES: A. C_L includes probe and fixture capacitance.
 B. The ac testing inputs are driven at 2.4 V for logic high and 0.45 V for logic low. Timing measurements are made at 2 V for logic high and 0.8 V for logic low on both inputs and outputs. Each device should have a 0.1- μ F ceramic capacitor connected between V_{CC} and V_{SS} as closely as possible to the device pins.

Figure 5. AC Test Output Load Circuit

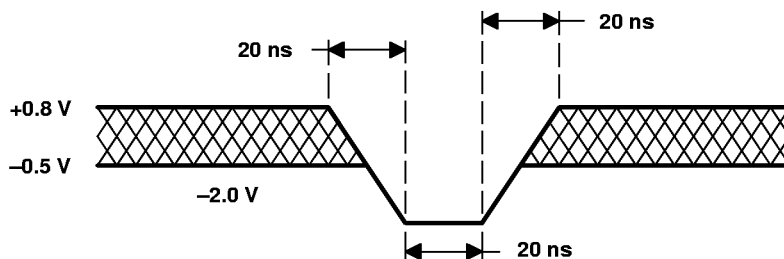

Figure 6. Maximum Negative Overshoot Waveform

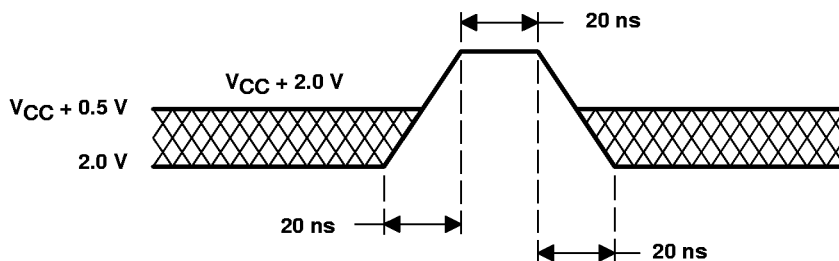

Figure 7. Maximum Positive Overshoot Waveform

PRODUCT PREVIEW



Please be aware that an important notice concerning availability, standard warranty, and use in critical applications of Texas Instruments semiconductor products and disclaimers thereto appears at the end of this data sheet.



PARAMETER MEASUREMENT INFORMATION

switching characteristics over recommended ranges of supply voltage and ambient temperature, read-only operation

PARAMETER	ALTERNATE SYMBOL	'29F400-80		'29F400-90		'29F400-100		'29F400-120		UNIT
		MIN	MAX	MIN	MAX	MIN	MAX	MIN	MAX	
$t_{c(R)}$ Cycle time, read	t_{AVAV}	80		90		100		120		ns
$t_{a(A)}$ Access time, address	t_{AVQV}		80		90		100		120	ns
$t_{a(E)}$ Access time, \overline{CE}	t_{ELQV}		80		90		100		120	ns
$t_{a(G)}$ Access time, \overline{OE}	t_{GLQV}		40		40		50		55	ns
$t_{dis(E)}$ Disable time, \overline{CE} to high impedance	t_{EHQZ}		30		30		30		40	ns
$t_{dis(G)}$ Disable time, \overline{OE} to high impedance	t_{GHQZ}		30		30		30		40	ns
$t_{en(E)}$ Enable time, \overline{CE} to low impedance	t_{ELQX}	0		0		0		0		ns
$t_{en(G)}$ Enable time, \overline{OE} to low impedance	t_{GLQX}	0		0		0		0		ns
$t_{h(D)}$ Hold time, output from address \overline{CE} or \overline{OE} change	t_{AXQX}	0		0		0		0		ns

PRODUCT PREVIEW



TMS29F400T, TMS29F400B
524288 BY 8-BIT/262144 BY 16-BIT
FLASH MEMORIES

SMJS843A – MAY 1997 – REVISED SEPTEMBER 1997

switching characteristics over recommended ranges of supply voltage and ambient temperature, controlled by \overline{WE}

PARAMETER		ALTERNATE SYMBOL	'29F400T/B-80			'29F400T/B-90			UNIT
			MIN	TYP	MAX	MIN	TYP	MAX	
$t_{c(W)}$	Cycle time, write	t_{AVAV}	80			90			ns
$t_{su(A)}$	Setup time, address	t_{AVWL}	0			0			ns
$t_h(A)$	Hold time, address	t_{WLAX}	45			50			ns
$t_{su(D)}$	Setup time, data	t_{DVWH}	45			50			ns
$t_h(D)$	Hold time, data valid after \overline{WE} high	t_{WHDX}	0			0			ns
$t_{su(E)}$	Setup time, \overline{CE}	t_{ELWL}	0			0			ns
$t_h(E)$	Hold time, \overline{CE}	t_{EHWH}	0			0			ns
$t_w(WL)$	Pulse duration, \overline{WE} low	t_{WLWH1}	45			50			ns
$t_w(WH)$	Pulse duration, \overline{WE} high	t_{WHWL}	20			30			ns
$t_{rec(R)}$	Recovery time, read before write	t_{GHWL}	0			0			ns
	Hold time, \overline{OE} read	t_{WHGL1}	0			0			ns
	Hold time, \overline{OE} toggle, data	t_{WHGL2}	10			10			ns
	Setup time, V_{CC}	t_{VCEL}	50			50			μs
	Transition time, V_{ID} (see Note 8 and Note 9)	t_{HVT}	4			4			μs
	Pulse duration, \overline{WE} low (see Note 8)	t_{WLWH2}	100			100			μs
	Pulse duration, \overline{WE} low (see Note 9)	t_{WLWH3}	10			10			ms
	Setup time, $\overline{CE} V_{ID}$ to \overline{WE} (see Note 9)	t_{EHVWL}	4			4			μs
	Setup time, $\overline{CE} V_{ID}$ to \overline{WE} (see Note 8 and Note 9)	t_{GHVWL}	4			4			μs
$t_{c(W)PR}$	Cycle time, programming operation	Byte	8			8			μs
		Word	14			14			μs
	Write recovery time from RY/\overline{BY}	t_{RB}	0			0			ns
	\overline{RESET} low time	t_{RL}	500			500			ns
	\overline{RESET} high time before read	t_{RH}	50			50			ns
	\overline{RESET} to power-down time	t_{RPD}	20			20			μs
	Program/erase valid to RY/\overline{BY} delay	t_{BUSY}	90			90			ns
	\overline{CE} to \overline{BYTE} switching low or high	t_{ELF}/t_{ELFH}	5			5			ns
	\overline{BYTE} switching low to output 3-state	t_{FLQZ}			30			30	ns
	\overline{BYTE} switching high to output active	t_{FHQV}			80			90	ns
$t_{c(W)ER}$	Cycle time, sector-erase operation	t_{WHWH2}		1			1		s
	Cycle time, chip-erase operation	t_{WHWH3}	6	40		6	40		s

NOTES: 8. Sector-protect timing
 9. Sector-unprotect timing

PRODUCT PREVIEW



switching characteristics over recommended ranges of supply voltage and ambient temperature, controlled by \overline{WE} (continued)

PARAMETER		ALTERNATE SYMBOL	'29F400T/B-100			'29F400T/B-120			UNIT
			MIN	TYP	MAX	MIN	TYP	MAX	
$t_{c(W)}$	Cycle time, write	t_{AVAV}	100			120			ns
$t_{su(A)}$	Setup time, address	t_{AVWL}	0			0			ns
$t_{h(A)}$	Hold time, address	t_{WLAX}	50			65			ns
$t_{su(D)}$	Setup time, data	t_{DVWH}	50			65			ns
$t_{h(D)}$	Hold time, data valid after \overline{WE} high	t_{WHDX}	0			0			ns
$t_{su(E)}$	Setup time, \overline{CE}	t_{ELWL}	0			0			ns
$t_{h(E)}$	Hold time, \overline{CE}	t_{EHWH}	0			0			ns
$t_{w(WL)}$	Pulse duration, \overline{WE} low	t_{WLWH1}	50			65			ns
$t_{w(WH)}$	Pulse duration, \overline{WE} high	t_{WHWL}	30			35			ns
$t_{rec(R)}$	Recovery time, read before write	t_{GHWL}	0			0			ns
	Hold time, \overline{OE} read	t_{WHGL1}	0			0			ns
	Hold time, \overline{OE} toggle, data	t_{WHGL2}	10			10			ns
	Setup time, V_{CC}	t_{VCEL}	50			50			μ s
	Transition time, V_{ID} (see Note 8 and Note 9)	t_{HVT}	4			4			μ s
	Pulse duration, \overline{WE} low (see Note 8)	t_{WLWH2}	100			100			μ s
	Pulse duration, \overline{WE} low (see Note 9)	t_{WLWH3}	10			10			ms
	Setup time, \overline{CE} V_{ID} to \overline{WE} (see Note 9)	t_{EHVWL}	4			4			μ s
	Setup time, \overline{CE} V_{ID} to \overline{WE} (see Note 8 and Note 9)	t_{GHVWL}	4			4			μ s
$t_{c(W)PR}$	Cycle time, programming operation	Word		8			8		μ s
		Byte		14			14		
	Write recovery time from $R\overline{Y}/\overline{B\overline{Y}}$	t_{RB}	0			0			ns
	\overline{RESET} low time	t_{RL}	500			500			ns
	\overline{RESET} high time before read	t_{RH}	50			50			ns
	\overline{RESET} to power-down time	t_{RPD}	20			20			μ s
	Program/erase valid to $R\overline{Y}/\overline{B\overline{Y}}$ delay	t_{BUSY}	90			90			ns
	\overline{CE} to \overline{BYTE} switching low or high	t_{ELF}/t_{ELFH}	5			5			ns
	\overline{BYTE} switching low to output 3-state	t_{FLQZ}			40			40	ns
	\overline{BYTE} switching high to output active	t_{FHQV}			100			120	ns
$t_{c(W)ER}$	Cycle time, sector-erase operation	t_{WHWH2}		1			1		s
	Cycle time, chip-erase operation	t_{WHWH3}		6	40		6	40	s

NOTES: 8. Sector-protect timing
9. Sector-unprotect timing

PRODUCT PREVIEW



TMS29F400T, TMS29F400B
524288 BY 8-BIT/262144 BY 16-BIT
FLASH MEMORIES

SMJS843A – MAY 1997 – REVISED SEPTEMBER 1997

switching characteristics over recommended ranges of supply voltage and ambient temperature, controlled by \overline{CE}

PARAMETER		ALTERNATE SYMBOL	'29F400T/B-80			'29F400T/B-90			UNIT
			MIN	TYP	MAX	MIN	TYP	MAX	
$t_{c(W)}$	Cycle time, write	t_{AVAV}	80			90			ns
$t_{su(A)}$	Setup time, address	t_{AVEL}	0			0			ns
$t_h(A)$	Hold time, address	t_{ELAX}	45			50			ns
$t_{su(D)}$	Setup time, data	t_{DVEH}	45			50			ns
$t_h(D)$	Hold time, data	t_{EHDX}	0			0			ns
$t_{su(W)}$	Setup time, \overline{WE}	t_{WLEL}	0			0			ns
$t_h(W)$	Hold time, \overline{WE}	t_{EHWH}	0			0			ns
$t_w(EL)$	Pulse duration, \overline{CE} low	t_{ELEH1}	45			50			ns
$t_w(EH)$	Pulse duration, \overline{CE} high	t_{EHEL}	20			30			ns
$t_{rec(R)}$	Recovery time, read before write	t_{GHFL}	0			0			ns
	Setup time, \overline{OE}	t_{GLEL}	0			0			ns
$t_h(C)$	Hold time, \overline{OE} read	t_{EHGL1}	0			0			ns
	Hold time, \overline{OE} toggle, data	t_{EHGL2}	10			10			ns
Programming operation		Byte	8			8			μ s
		Word	14			14			μ s
	Cycle time, sector-erase operation	t_{EHEH2}	1			1			s
	Cycle time, chip-erase operation	t_{EHEH3}	6 40			6 40			s
	\overline{BYTE} switching low to output 3-state	t_{FLQZ}	30			30			ns

PRODUCT PREVIEW



TMS29F400T, TMS29F400B
524288 BY 8-BIT/262144 BY 16-BIT
FLASH MEMORIES

SMJS843A – MAY 1997 – REVISED SEPTEMBER 1997

switching characteristics over recommended ranges of supply voltage and ambient temperature, controlled by \overline{CE} (continued)

PARAMETER		ALTERNATE SYMBOL	'29F400T/B-100			'29F400T/B-120			UNIT
			MIN	TYP	MAX	MIN	TYP	MAX	
$t_{c(W)}$	Cycle time, write	t_{AVAV}	100			120			ns
$t_{su(A)}$	Setup time, address	t_{AVEL}	0			0			ns
$t_{h(A)}$	Hold time, address	t_{ELAX}	50			65			ns
$t_{su(D)}$	Setup time, data	t_{DVEH}	50			65			ns
$t_{h(D)}$	Hold time, data	t_{EHDX}	0			0			ns
$t_{su(W)}$	Setup time, \overline{WE}	t_{WLEL}	0			0			ns
$t_{h(W)}$	Hold time, \overline{WE}	t_{EHWH}	0			0			ns
$t_{w(EL)}$	Pulse duration, \overline{CE} low	t_{ELEH1}	50			65			ns
$t_{w(EH)}$	Pulse duration, \overline{CE} high	t_{EHEL}	30			35			ns
$t_{rec(R)}$	Recovery time, read before write	t_{GHLE}	0			0			ns
	Setup time, \overline{OE}	t_{GLEL}	0			0			ns
$t_{h(C)}$	Hold time, \overline{OE} read	t_{EHGL1}	0			0			ns
	Hold time, \overline{OE} toggle, data	t_{EHGL2}	10			10			ns
Programming operation	Byte	t_{EHEH1}		8			8		μs
	Word	t_{EHEH1}		14			14		μs
	Cycle time, sector-erase operation	t_{EHEH2}		1			1		s
	Cycle time, chip-erase operation	t_{EHEH3}		6	40		6	40	s
	\overline{BYTE} switching low to output 3-state	t_{FLQZ}			40			40	ns

PRODUCT PREVIEW



TMS29F400T, TMS29F400B 524288 BY 8-BIT/262144 BY 16-BIT FLASH MEMORIES

SMJS843A – MAY 1997 – REVISED SEPTEMBER 1997

erase and program performance†

PARAMETER	TEST CONDITIONS	MIN	TYP	MAX	UNIT
Sector-erase time	Excludes 00H programming prior to erasure		1‡	15§	s
Program Word time	Excludes system-level overhead	9	11	5200§	µs
Program byte time	Excludes system-level overhead	9	9	3600§	µs
Chip-programming time	Excludes system-level overhead		6‡	50§	s
Erase/program cycles		100000	1000000		cycles

† The internal algorithms allow for 2.5-ms byte-program time. DQ5 = 1 only after a byte takes the theoretical maximum time to program. A minimal number of bytes can require significantly more programming pulses than the typical byte. The majority of the bytes program within one or two pulses. This is demonstrated by the typical and maximum programming time listed above.

‡ 25°C, 5-V V_{CC}, 100000 cycles, typical pattern

§ Under worst-case conditions: 90°C, 5-V V_{CC}, 100000 cycles

latchup characteristics (see Note 10)

PARAMETER	MIN	MAX	UNIT
Input voltage with respect to V _{SS} on all pins except I/O pins (including A9 and \overline{OE})	-1	13	V
Input voltage with respect to V _{SS} on all I/O pins	-1	V _{CC} + 1	V
Current	-100	100	mA

NOTE 10: Includes all pins except V_{CC} test conditions: V_{CC} = 5 V, one pin at a time

pin capacitance, all packages (see Note 11)

PARAMETER	TEST CONDITIONS	TYP	MAX	UNIT
C _{IN} Input capacitance	V _{IN} = 0	6	7.5	pF
C _{OUT} Output capacitance	V _{OUT} = 0	8.5	12	pF
C _{IN2} Control pin capacitance	V _{IN} = 0	8	10	pF

NOTE 11: Test conditions: T_A = 25°C, f = 1 MHz

data retention

PARAMETER	TEST CONDITIONS	MIN	MAX	UNIT
Minimum pattern data retention time	150°C	10		Years
	125°C	20		

read operation

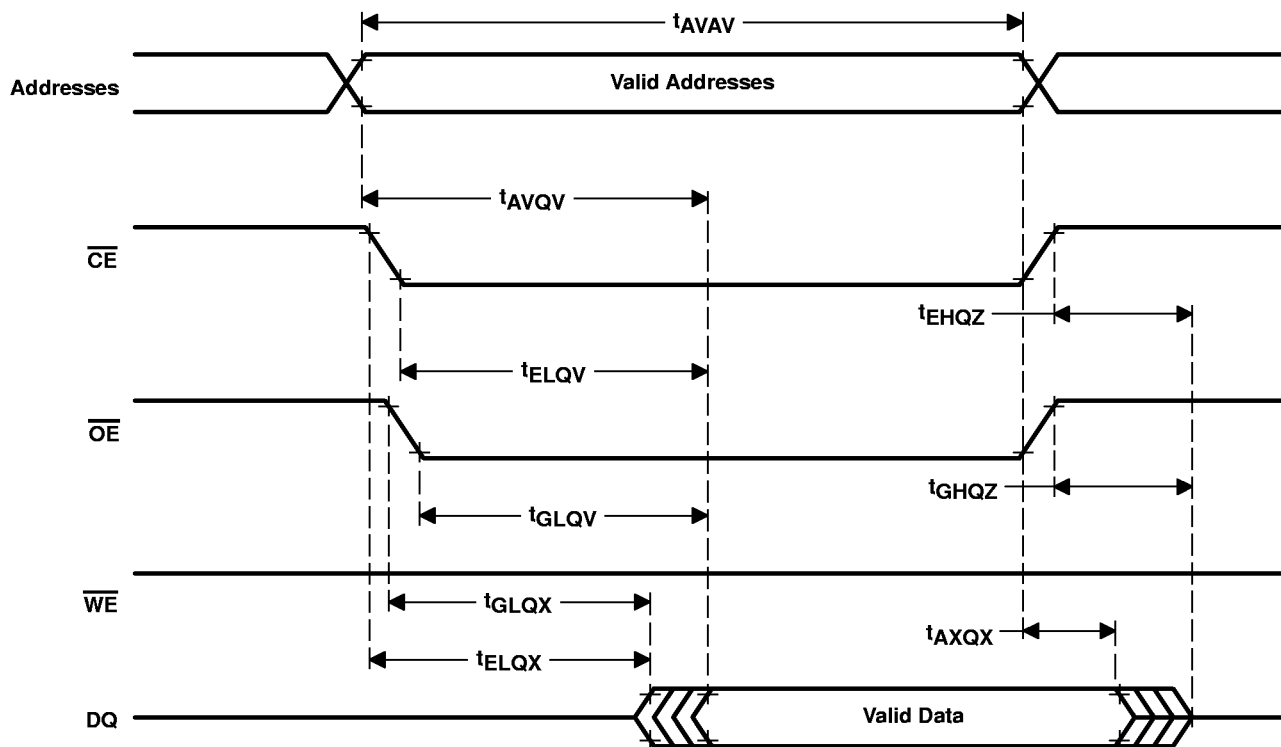

Figure 8. AC Waveform for Read Operation

PRODUCT PREVIEW



write operation

PRODUCT PREVIEW

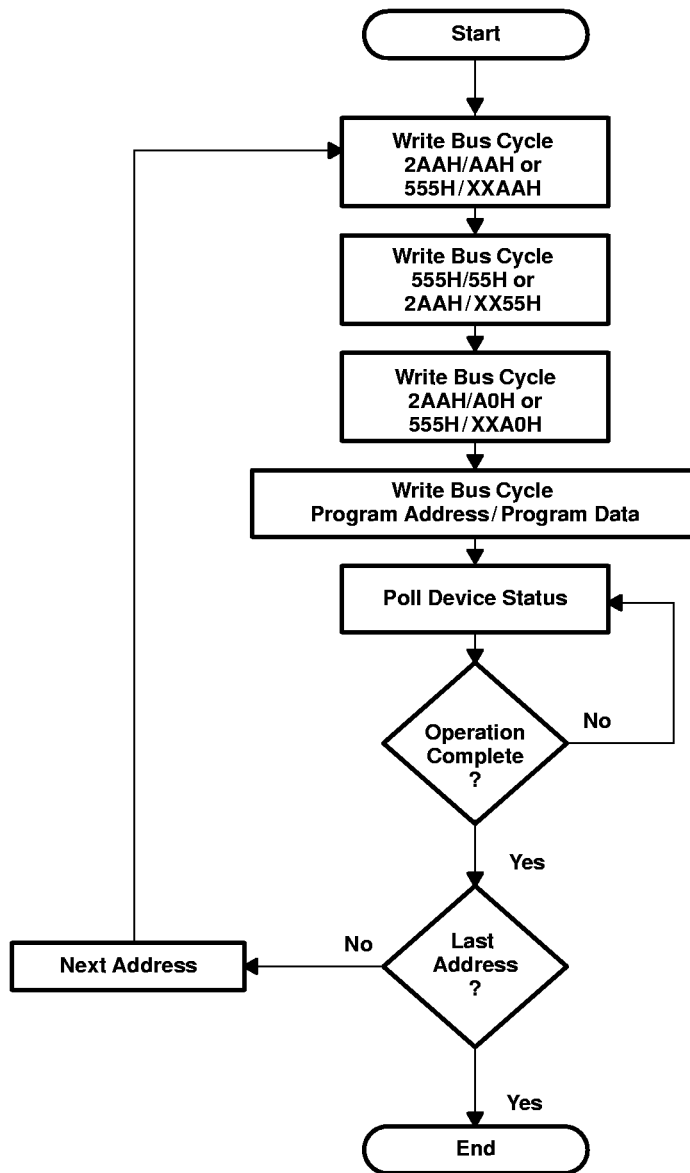
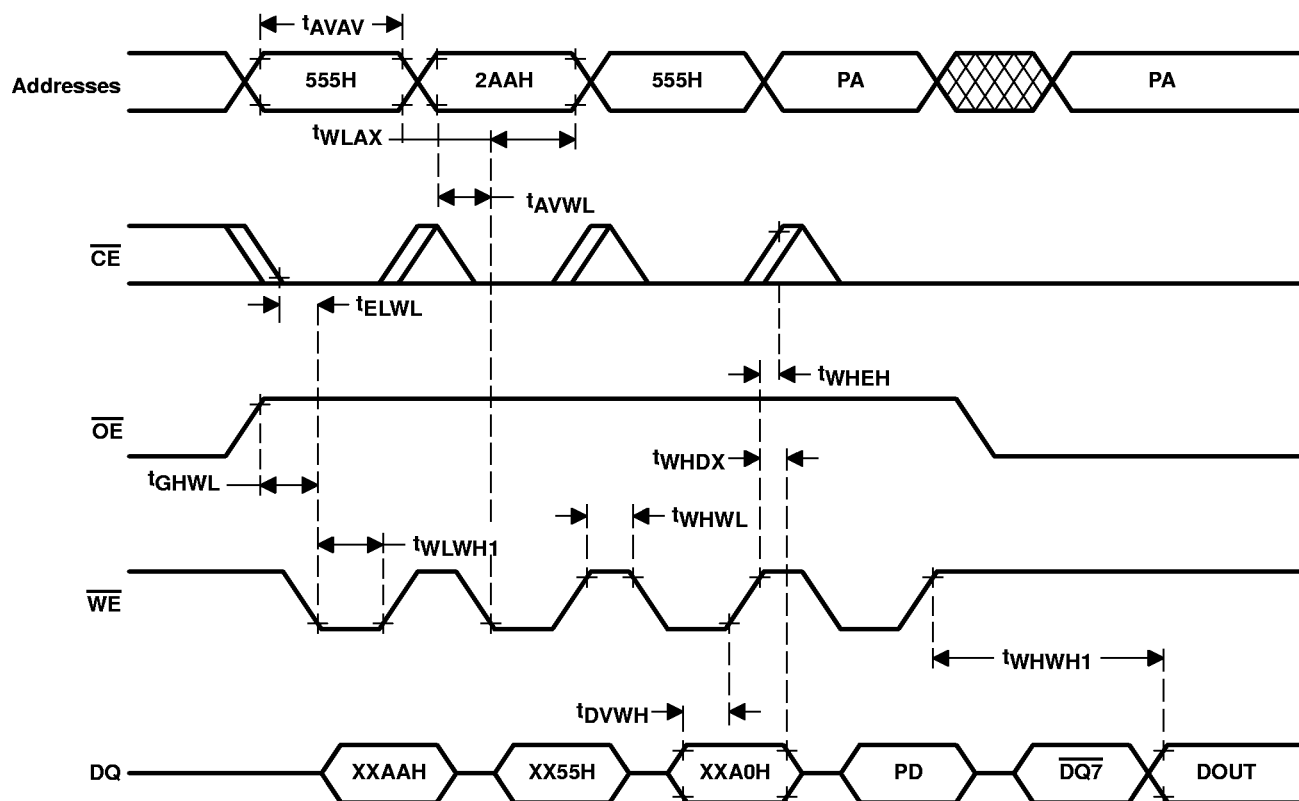

Figure 9. Program Algorithm

write operation (continued)



- NOTES: A. PA = Address to be programmed
 B. PD = Data to be programmed
 C. DQ7 = Complement of data written to DQ7
 D. Timing diagrams shown are for word-mode operation.

Figure 10. AC Waveform for Program Operation

PRODUCT PREVIEW

TMS29F400T, TMS29F400B
524288 BY 8-BIT/262144 BY 16-BIT
FLASH MEMORIES

SMJS843A – MAY 1997 – REVISED SEPTEMBER 1997

write operation (continued)

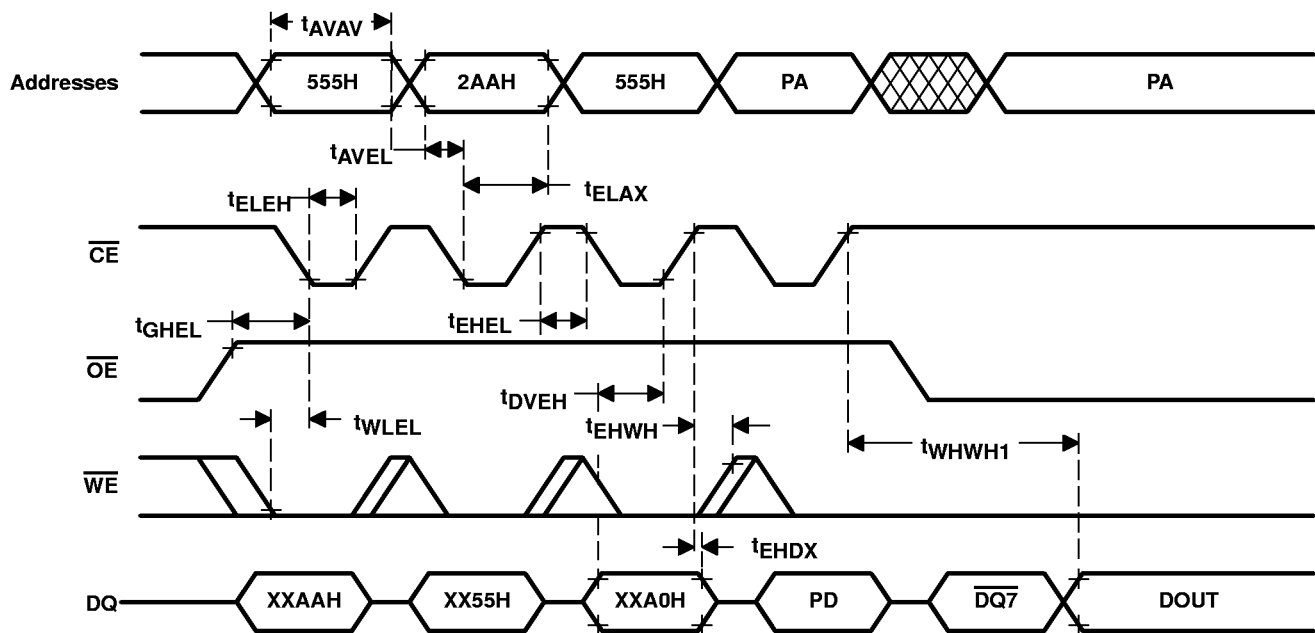

- NOTES: A. PA = Address to be programmed
 B. PD = Data to be programmed
 C. $\overline{DQ7}$ = Complement of data written to DQ7
 D. Timing diagrams shown are for word-mode operation.

Figure 11. Alternate \overline{CE} -Controlled Write Operation

PRODUCT PREVIEW



chip-erase operation

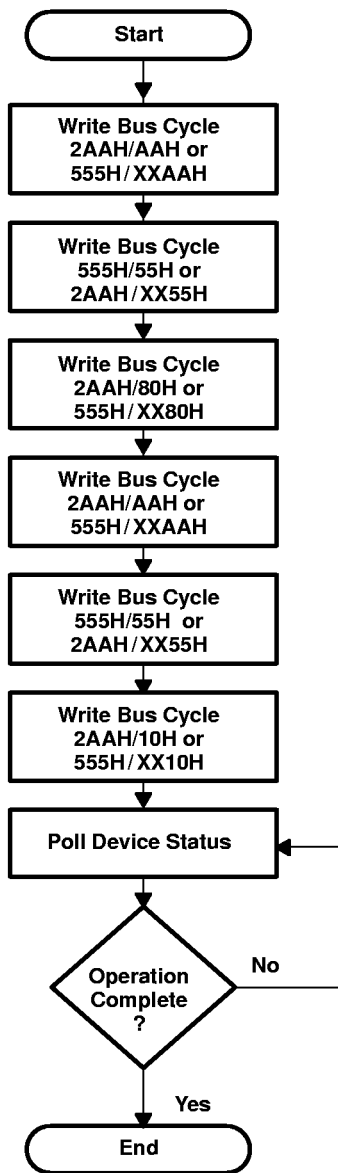

Figure 12. Chip-Erase Algorithm

PRODUCT PREVIEW

TMS29F400T, TMS29F400B
524288 BY 8-BIT/262144 BY 16-BIT
FLASH MEMORIES

SMJS843A – MAY 1997 – REVISED SEPTEMBER 1997

chip-erase operation (continued)

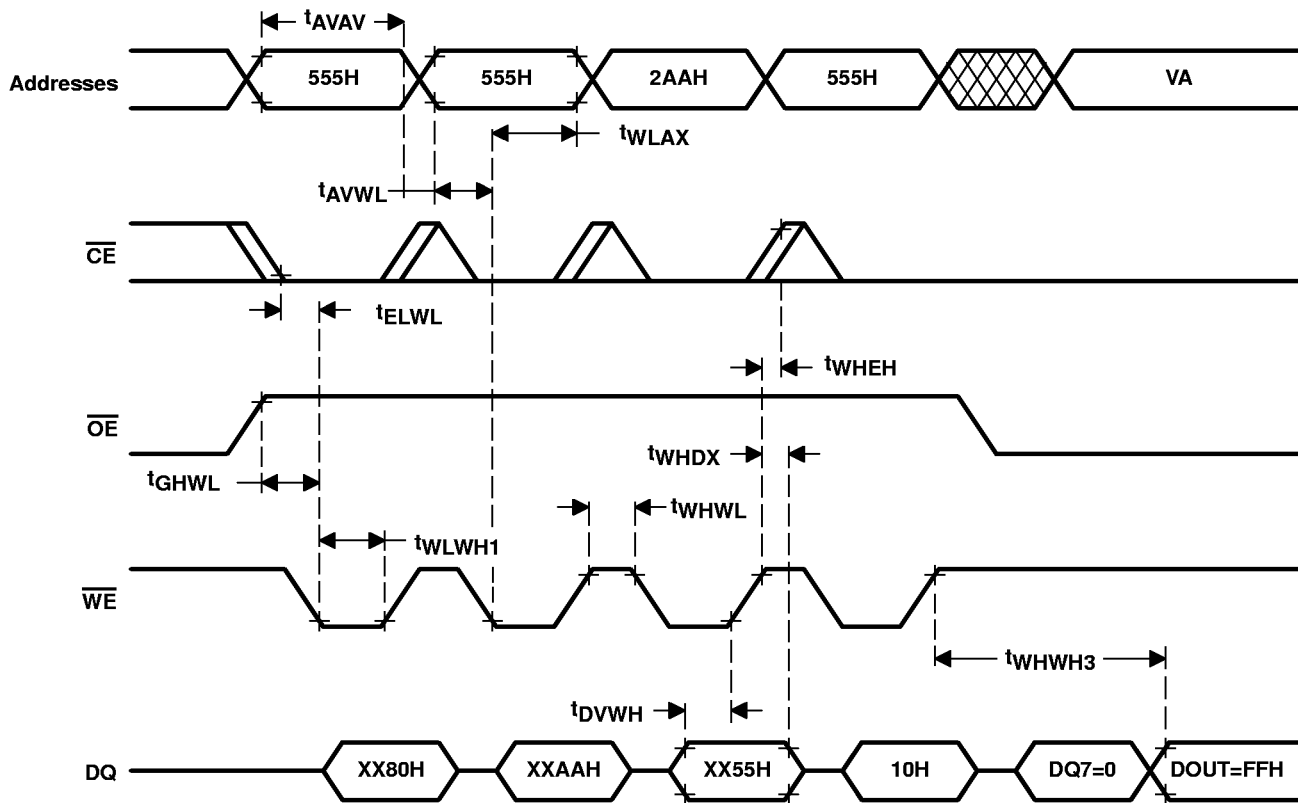

- NOTES: A. VA = any valid address
 B. Figure details the last four bus cycles in a six-bus-cycle operation.
 C. Timing diagrams shown are for word-mode operation.

Figure 13. AC Waveform for Chip-Erase Operation

PRODUCT PREVIEW



sector-erase operation

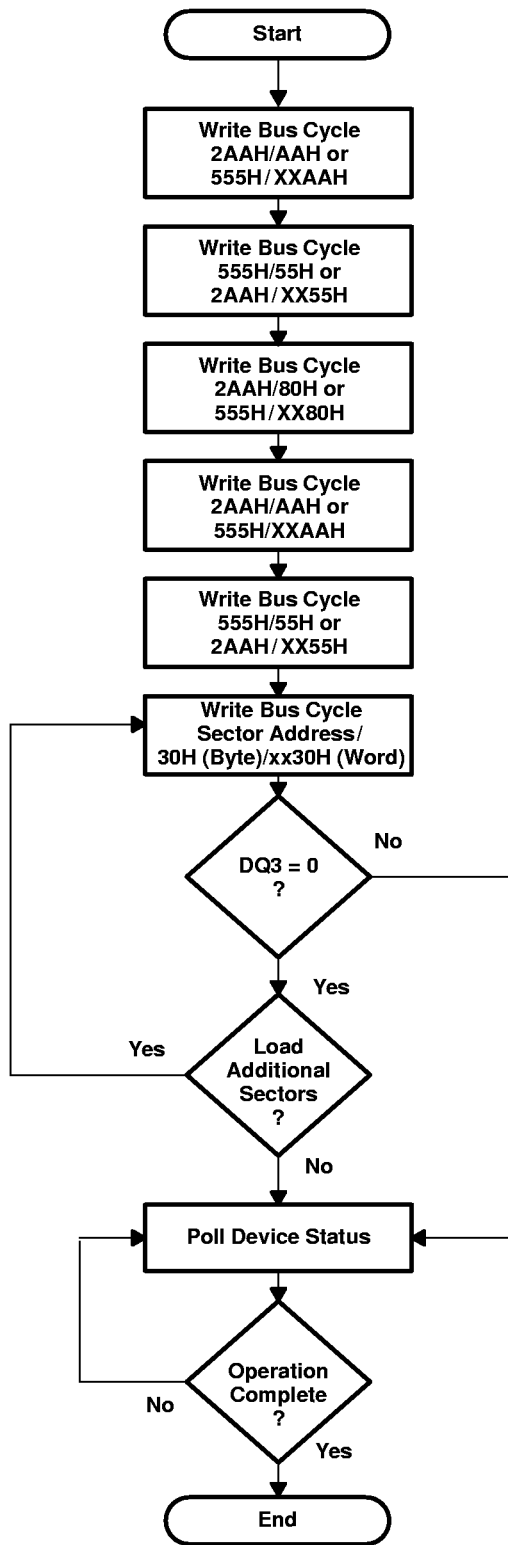

Figure 14. Sector-Erase Algorithm

PRODUCT PREVIEW



TMS29F400T, TMS29F400B
524288 BY 8-BIT/262144 BY 16-BIT
FLASH MEMORIES

SMJS843A – MAY 1997 – REVISED SEPTEMBER 1997

sector-erase operation (continued)

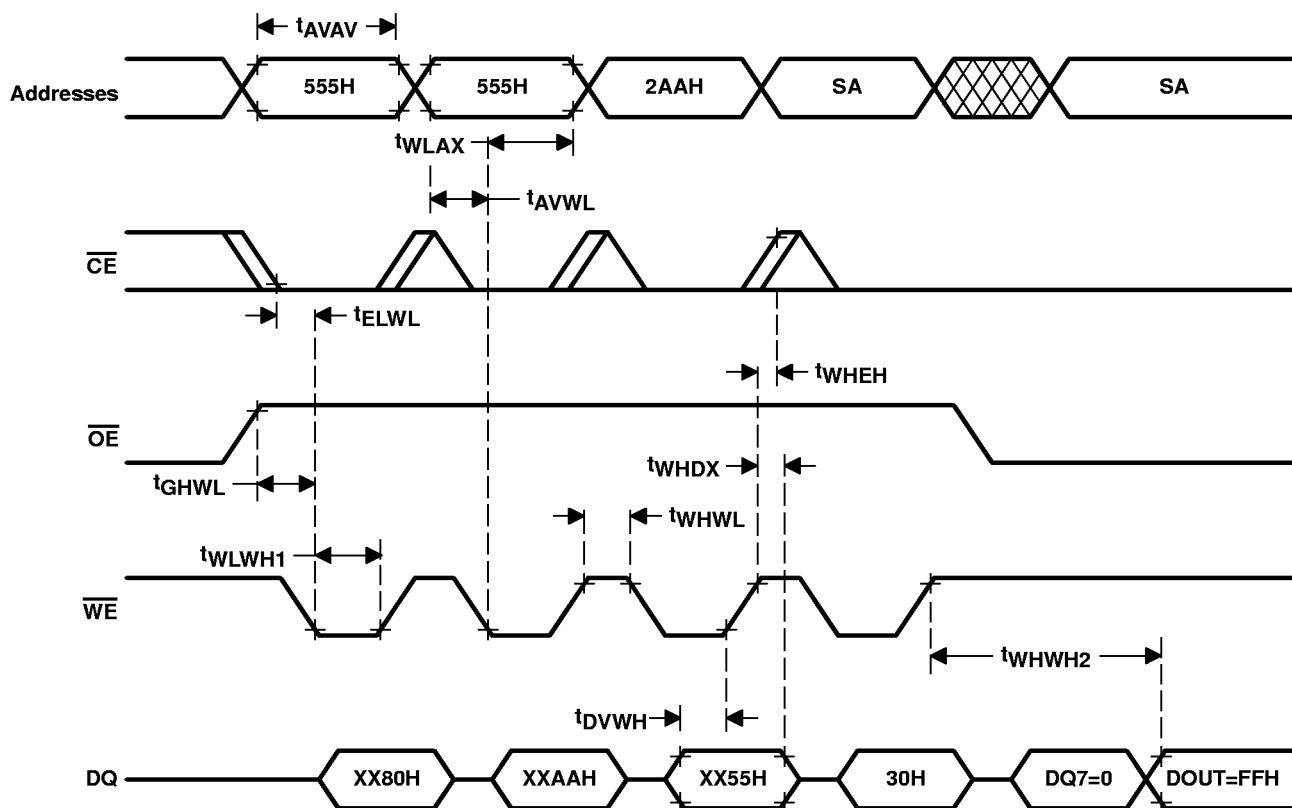

- NOTES: A. SA = Sector address to be erased
 B. Figure details the last four bus cycles in a six-bus-cycle operation.
 C. Timing diagrams shown are for word-mode operation.

Figure 15. AC Waveform for Sector-Erase Operation

PRODUCT PREVIEW



data-polling operation

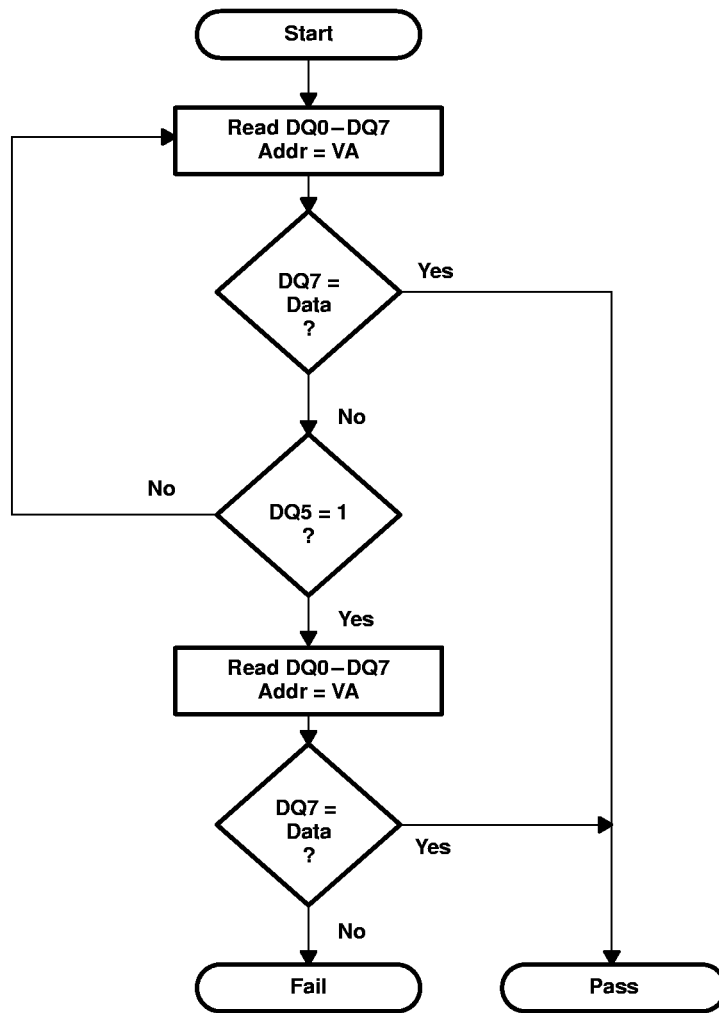

- NOTES: A. Polling status bits DQ7 and DQ5 may change asynchronously.
Read DQ7 after DQ5 changes states.
B. VA = Program address for byte-programming
= Selected sector address for sector erase
= Any valid address for chip erase

Figure 16. Data-Polling Algorithm

PRODUCT PREVIEW



TMS29F400T, TMS29F400B
524288 BY 8-BIT/262144 BY 16-BIT
FLASH MEMORIES

SMJS843A – MAY 1997 – REVISED SEPTEMBER 1997

data-polling operation (continued)

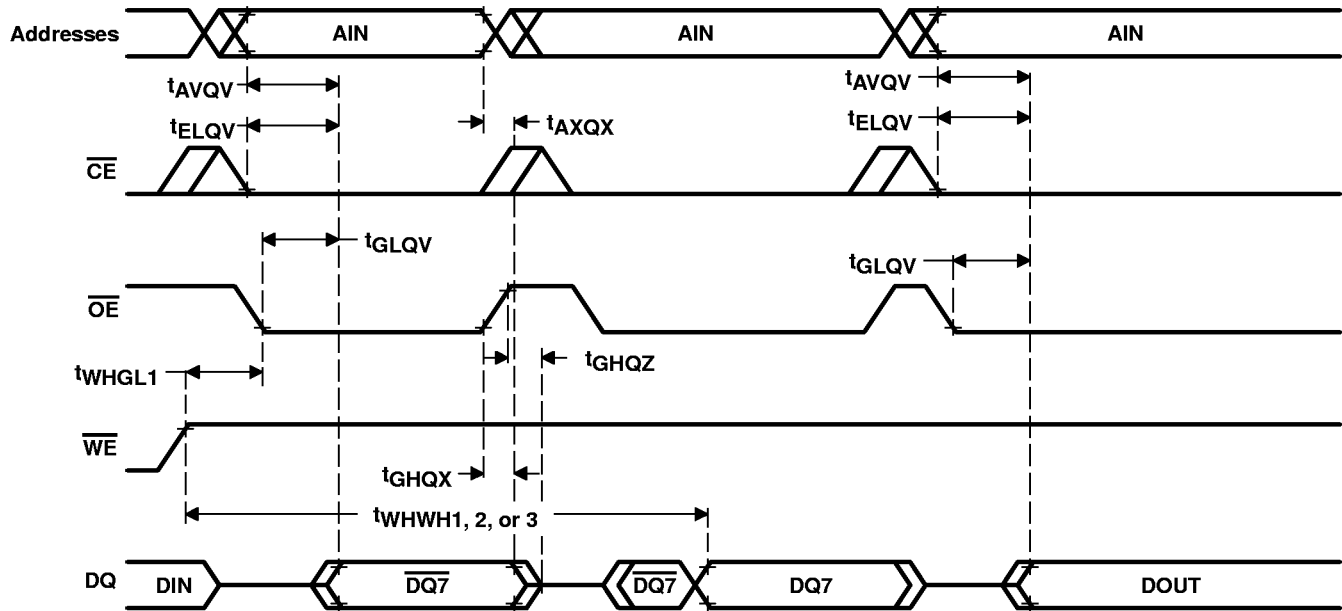

- NOTES: A. \overline{DIN} = Last command data written to the device
 B. $\overline{DQ7}$ = Complement of data written to DQ7
 C. DOUT = Valid data output
 D. AIN = Valid address for byte-program, sector-erase, or chip-erase operation

Figure 17. AC Waveform for Data-Polling Operation

PRODUCT PREVIEW



toggle-bit operation

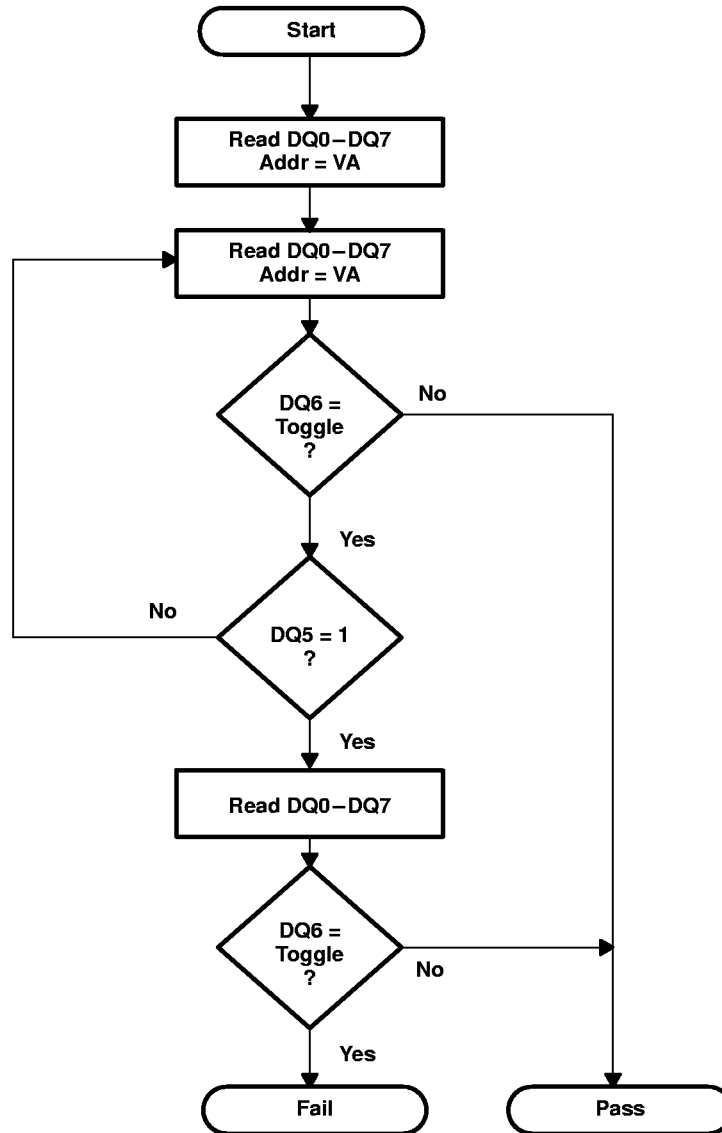

NOTE A: Polling status bits DQ6 and DQ5 can change asynchronously. Read DQ6 after DQ5 changes states.

Figure 18. Toggle-Bit Algorithm

PRODUCT PREVIEW



TMS29F400T, TMS29F400B
524288 BY 8-BIT/262144 BY 16-BIT
FLASH MEMORIES

SMJS843A – MAY 1997 – REVISED SEPTEMBER 1997

toggle-bit operation (continued)

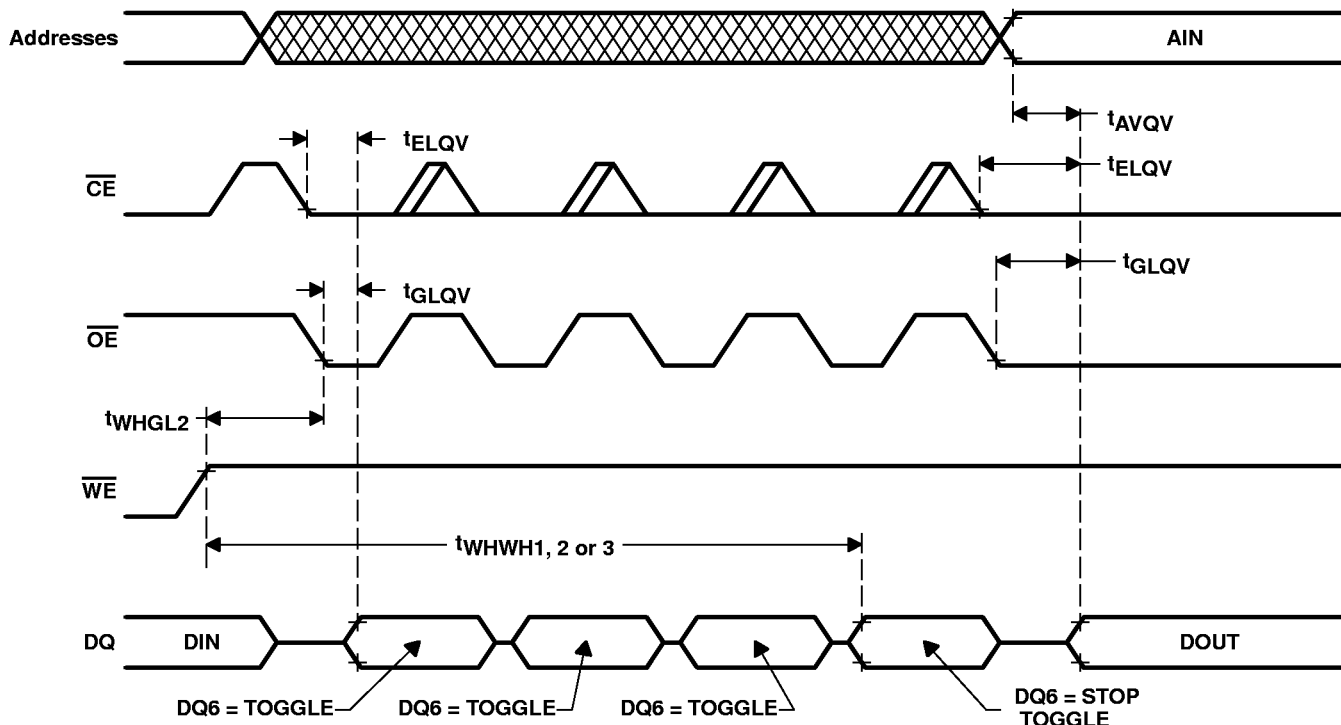

- NOTES:
- A. DIN = Last command data written to the device
 - B. DQ6 = Toggle bit output
 - C. DOUT = Valid data output
 - D. AIN = Valid address for byte-program, sector-erase, or chip-erase operation

Figure 19. AC Waveforms for Toggle-Bit Operation

PRODUCT PREVIEW



sector-protect operation

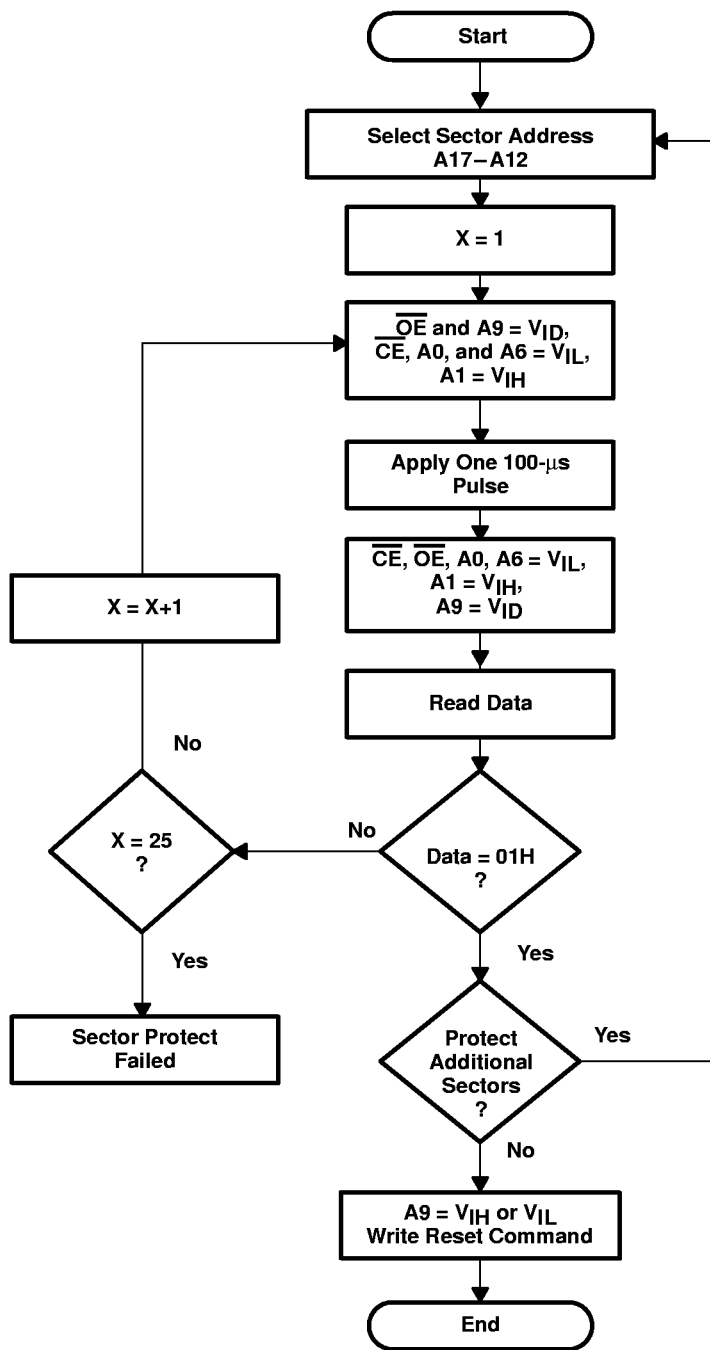

Figure 20. Sector-Protect Algorithm

PRODUCT PREVIEW

TMS29F400T, TMS29F400B
524288 BY 8-BIT/262144 BY 16-BIT
FLASH MEMORIES

SMJS843A – MAY 1997 – REVISED SEPTEMBER 1997

sector-protect operation (continued)

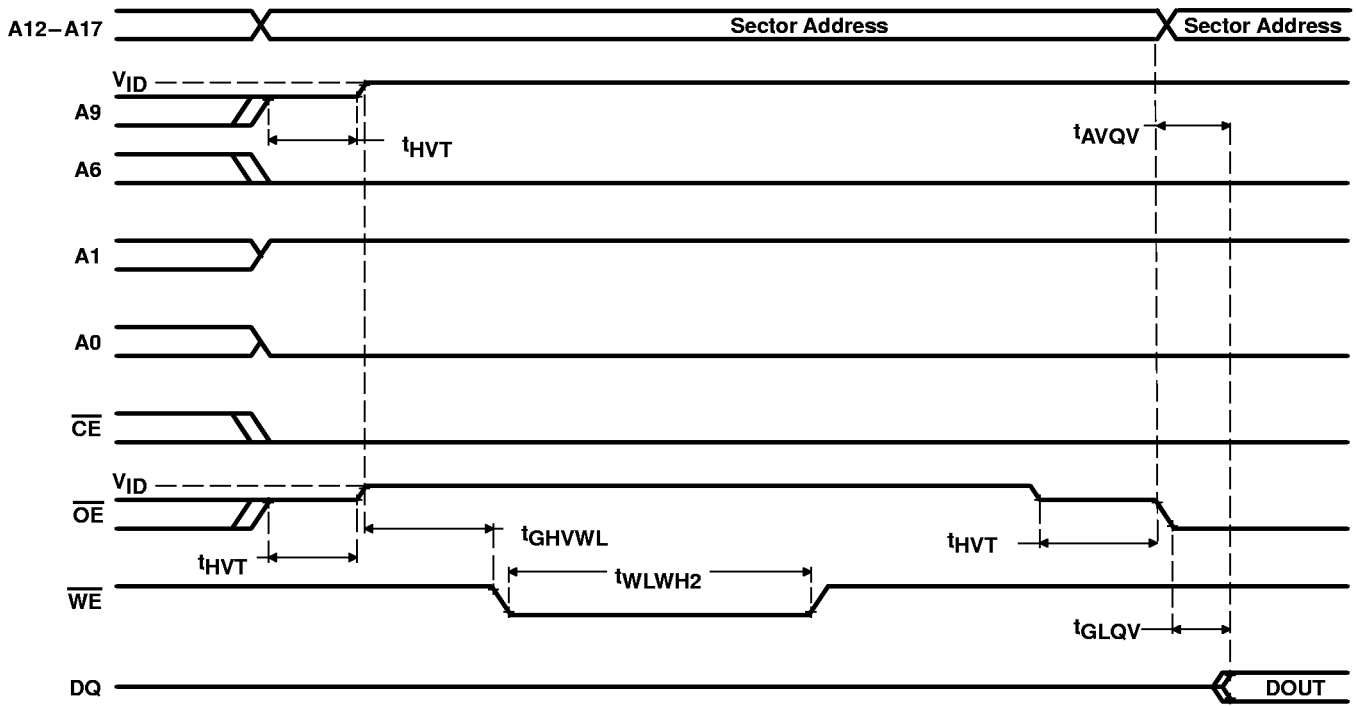

NOTE A: DOUT = 00H if selected sector is not protected,
 01H if the sector is protected

Figure 21. AC Waveform for Sector-Protect Operation

PRODUCT PREVIEW



sector-unprotect operation

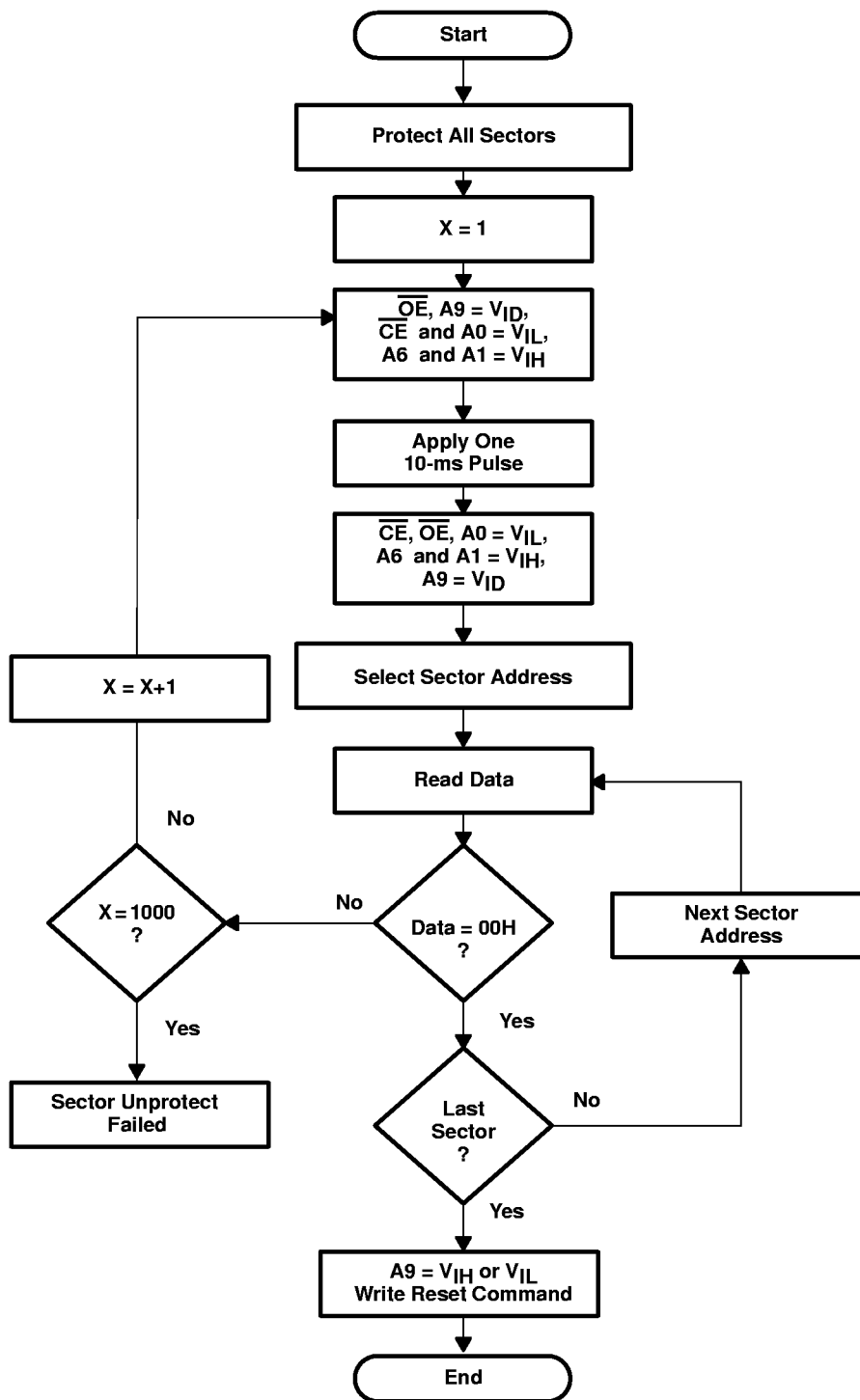

Figure 22. Sector-Unprotect Algorithm

PRODUCT PREVIEW



TMS29F400T, TMS29F400B
524288 BY 8-BIT/262144 BY 16-BIT
FLASH MEMORIES

SMJS843A – MAY 1997 – REVISED SEPTEMBER 1997

sector-unprotect operation (continued)

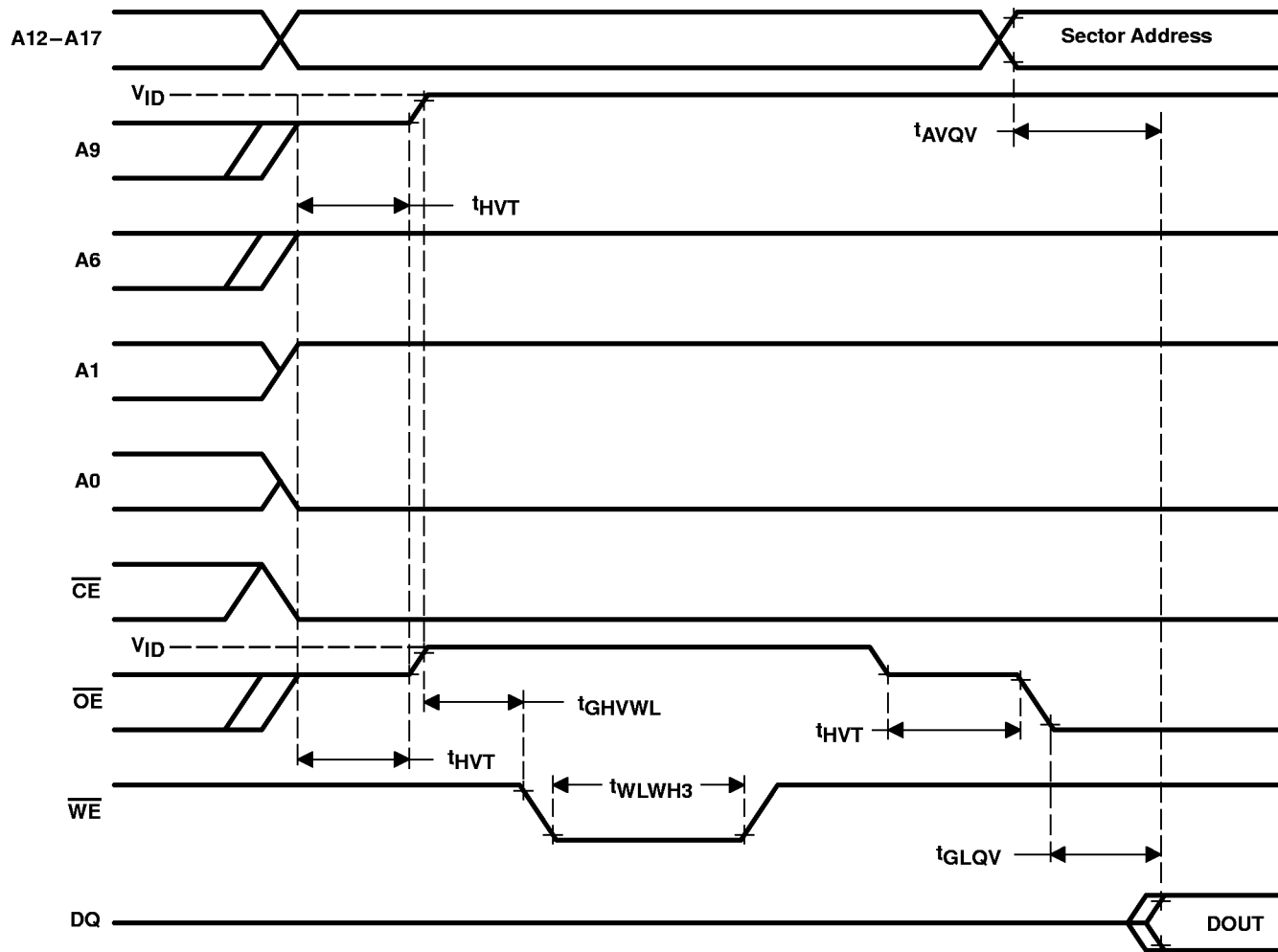

NOTE A: DOUT = 00H if selected sector is not protected,
 01H if the sector is protected

Figure 23. AC Waveform for Sector-Unprotect Operation

PRODUCT PREVIEW



temporary sector-unprotect operation

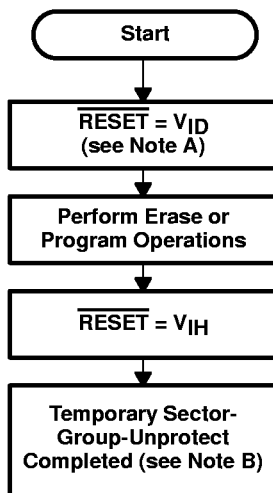

- NOTES: A. All protected sectors unprotected
 B. All previously protected sectors are protected once again

Figure 24. Temporary Sector-Unprotect Algorithm

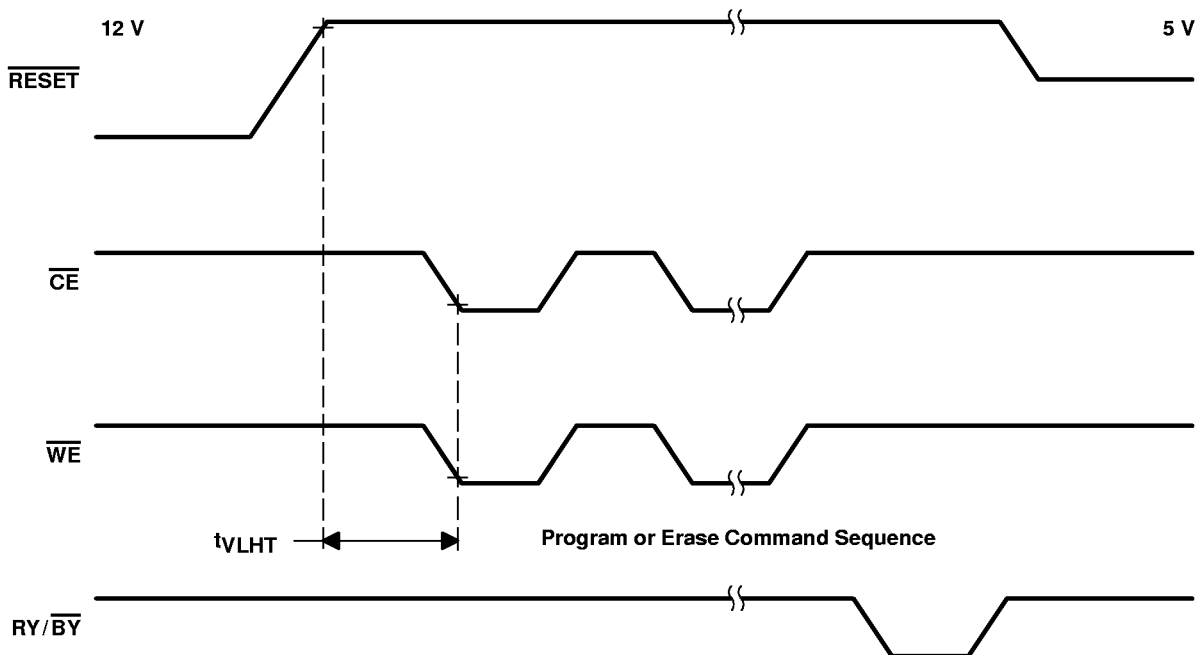

Figure 25. Temporary Sector-Unprotect Timing Diagram

PRODUCT PREVIEW



PARAMETER MEASUREMENT INFORMATION

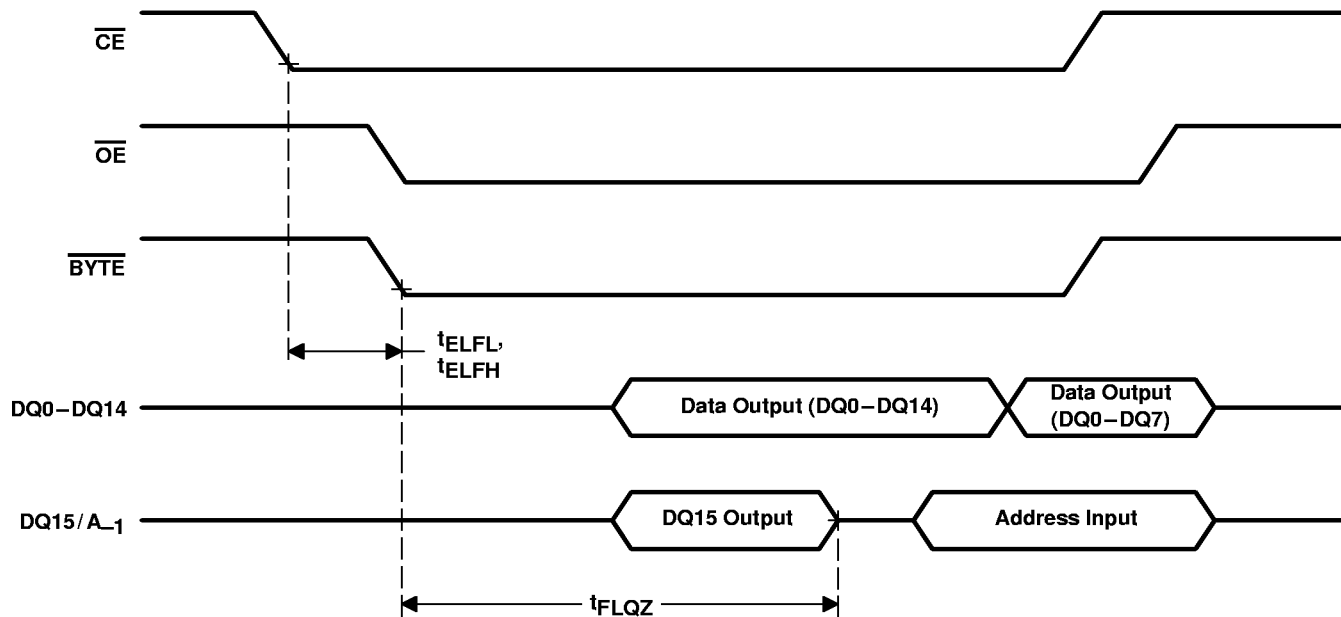

Figure 26. \overline{BYTE} Timing Diagram for Read Operation

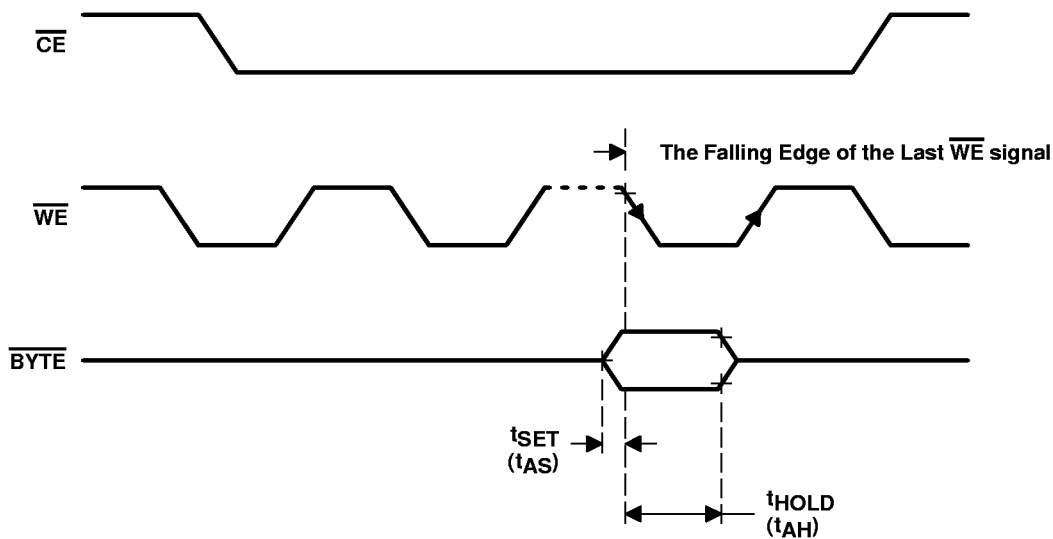

Figure 27. \overline{BYTE} Timing Diagram for Write Operation

PRODUCT PREVIEW



PARAMETER MEASUREMENT INFORMATION

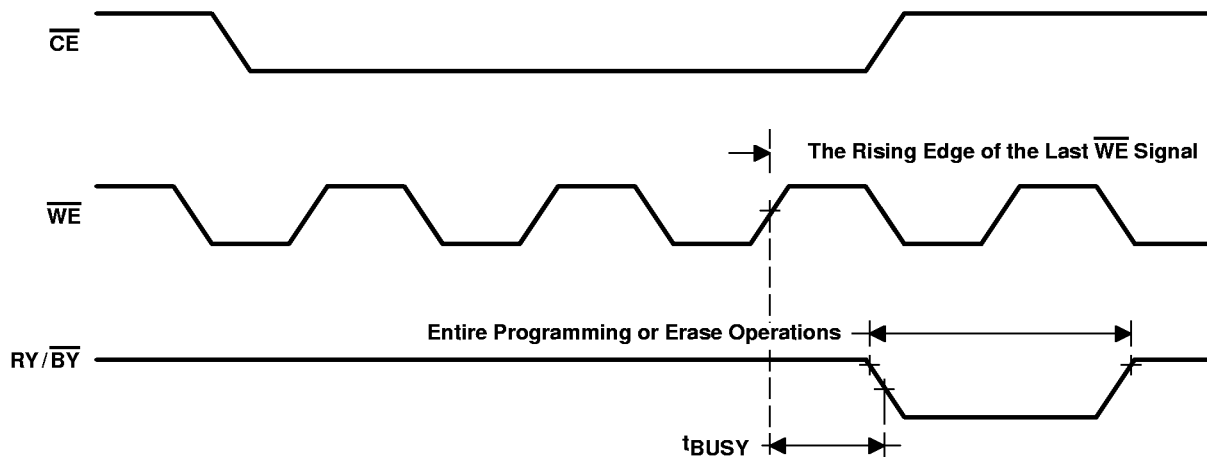

Figure 28. RY/\overline{BY} Timing Diagram During Program/Erase Operations

PRODUCT PREVIEW

TMS29F400T, TMS29F400B
524288 BY 8-BIT/262144 BY 16-BIT
FLASH MEMORIES

SMJS843A – MAY 1997 – REVISED SEPTEMBER 1997

MECHANICAL DATA

DBJ (R-PDSO-G44)

PLASTIC SMALL-OUTLINE PACKAGE

PRODUCT PREVIEW

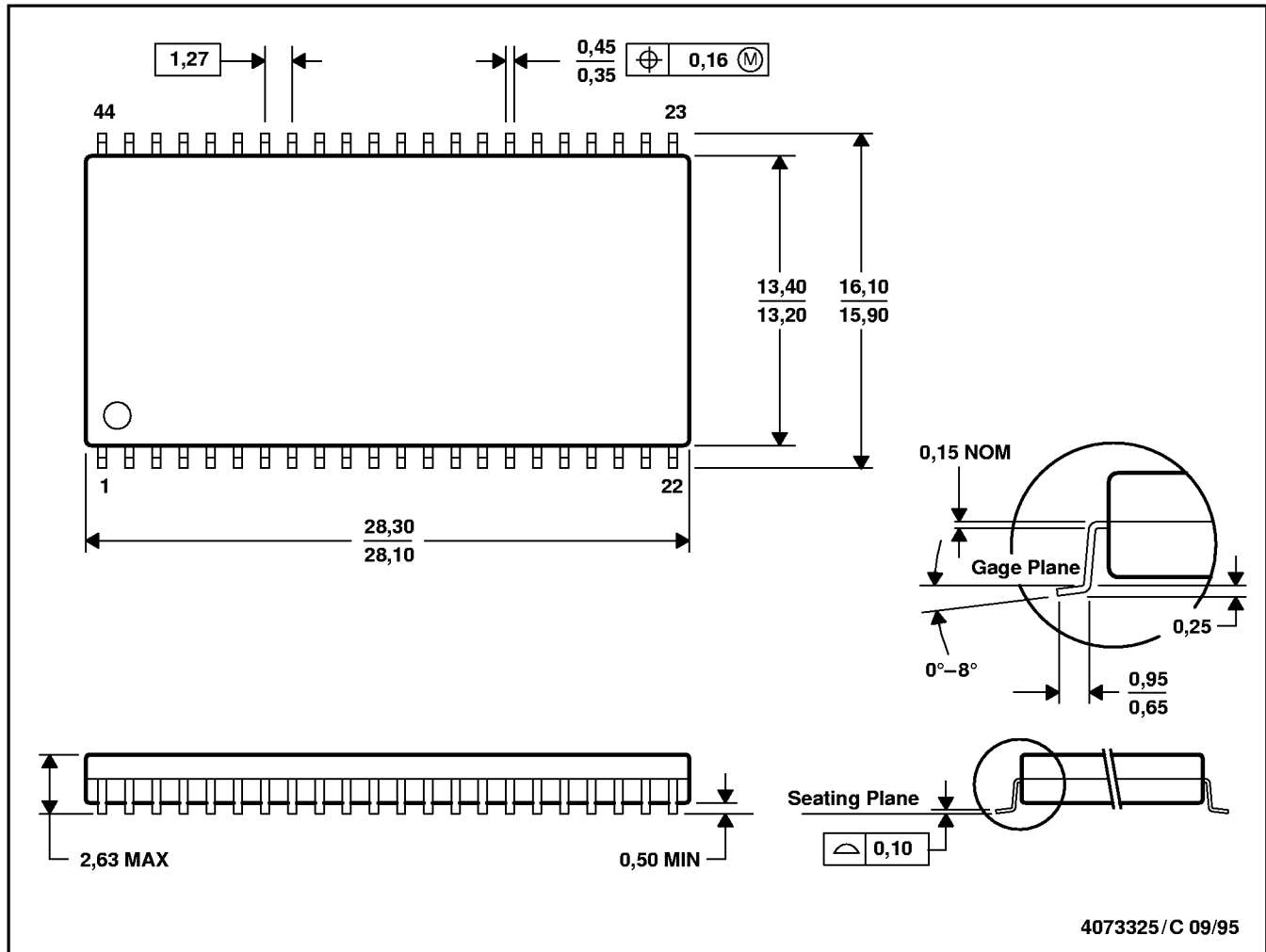

- NOTES: A. All linear dimensions are in millimeters.
 B. This drawing is subject to change without notice.
 C. Body dimensions do not include mold flash or protrusion.



MECHANICAL DATA

DCD (R-PDSO-G**)

PLASTIC DUAL SMALL-OUTLINE PACKAGE

40 PIN SHOWN

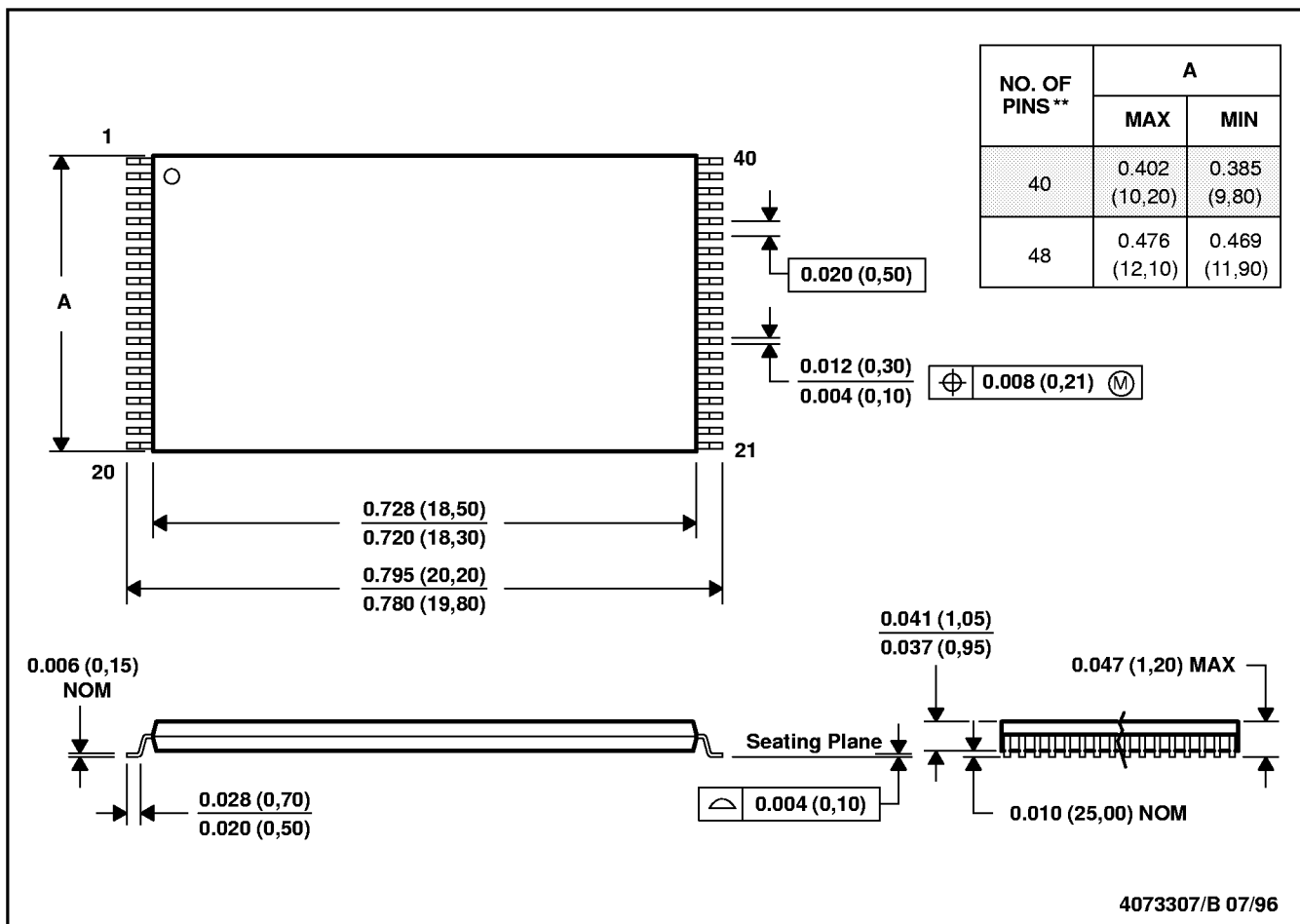

NOTES: A. All linear dimensions are in inches (millimeters).
 B. This drawing is subject to change without notice.

PRODUCT PREVIEW