

CAT93C46R

1K-Bit Microwire Serial EEPROM

FEATURES

- High speed operation: 1MHz
- Low power CMOS technology
- 1.8 to 5.5 volt operation
- Selectable x8 or x16 memory organization
- Self-timed write cycle with auto-clear
- Hardware and software write protection
- Power-up inadvertant write protection
- 1,000,000 Program/erase cycles
- 100 year data retention
- Industrial temperature range
- RoHS compliant “Green” & “Gold”
8-pin PDIP, SOIC, TSSOP and TDFN packages

DESCRIPTION

The CAT93C46R is a 1K-bit Serial EEPROM memory device which is configured as either registers of 16 bits (ORG pin at V_{CC}) or 8 bits (ORG pin at GND). Each register can be written (or read) serially by using the DI (or DO) pin. The CAT93C46R is manufactured using Catalyst’s advanced CMOS EEPROM floating gate technology. The device is designed to endure 1,000,000 program/erase cycles and has a data retention of 100 years. The device is available in 8-pin DIP, 8-pin SOIC, 8-pin TSSOP and 8-pad TDFN packages.

PIN CONFIGURATION

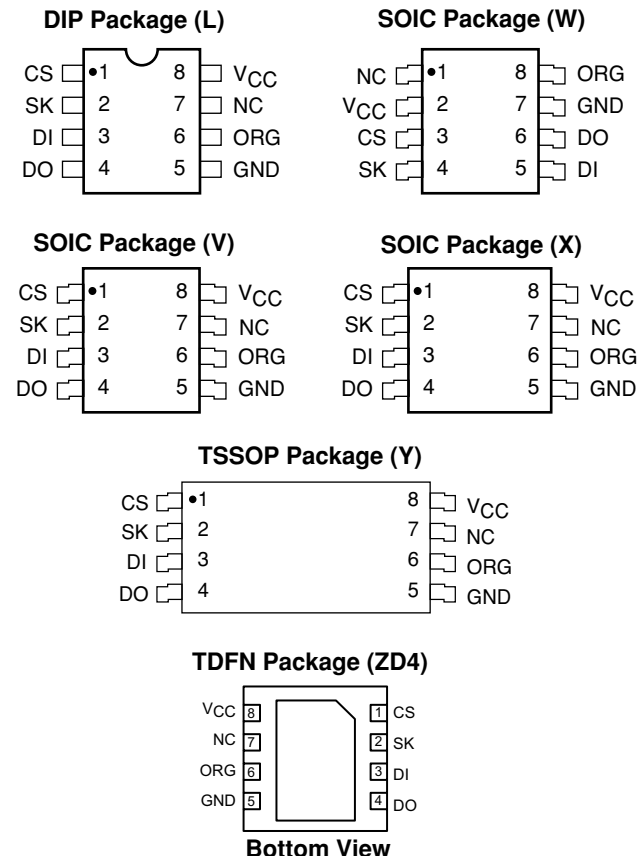

FUNCTIONAL SYMBOL

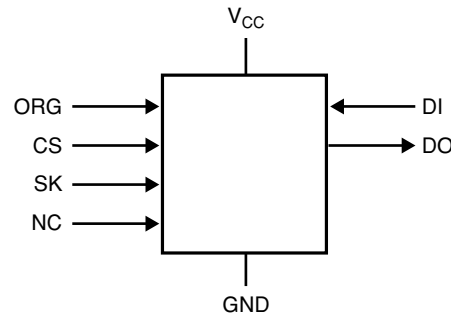

PIN FUNCTIONS

Pin Name	Function
CS	Chip Select
SK	Clock Input
DI	Serial Data Input
DO	Serial Data Output
V _{CC}	+1.8V to 5.5V Power Supply
GND	Ground
ORG	Memory Organization
NC	No Connection

Note: When the ORG pin is connected to V_{CC}, the x16 organization is selected. When it is connected to ground, the x8 pin is selected. If the ORG pin is left unconnected, then an internal pullup device will select the x16 organization.

ABSOLUTE MAXIMUM RATINGS*

Storage Temperature	-65°C to +150°C
Voltage on Any Pin with Respect to Ground ⁽¹⁾	-0.5 V to +6.5 V

* Stresses above those listed under “Absolute Maximum Ratings” may cause permanent damage to the device. These are stress ratings only, and functional operation of the device at these or any other conditions outside of those listed in the operational sections of this specification is not implied. Exposure to any absolute maximum rating for extended periods may affect device performance and reliability.

RELIABILITY CHARACTERISTICS⁽²⁾

Symbol	Parameter	Min	Units
$N_{END}^{(*)}$	Endurance	1,000,000	Program/ Erase Cycles
T_{DR}	Data Retention	100	Years

D.C. OPERATING CHARACTERISTICS

$V_{CC} = +1.8V$ to $+5.5V$, unless otherwise specified.

Symbol	Parameter	Test Conditions	Min	Typ	Max	Units
I_{CC1}	Power Supply Current (Write)	$f_{SK} = 1MHz$ $V_{CC} = 5.0V$			3	mA
I_{CC2}	Power Supply Current (Read)	$f_{SK} = 1MHz$ $V_{CC} = 5.0V$			500	μA
I_{SB1}	Power Supply Current (Standby) (x8 Mode)	$CS = 0V$ $ORG = GND$			10	μA
I_{SB2}	Power Supply Current (Standby) (x16 Mode)	$CS = 0V$ $ORG = Float$ or V_{CC}		0	10	μA
I_{LI}	Input Leakage Current	$V_{IN} = 0V$ to V_{CC}			2	μA
I_{LO}	Output Leakage Current (Including ORG pin)	$V_{OUT} = 0V$ to V_{CC} , $CS = 0V$			2	μA
V_{IL1}	Input Low Voltage	$4.5V \leq V_{CC} < 5.5V$	-0.1		0.8	V
V_{IH1}	Input High Voltage	$4.5V \leq V_{CC} < 5.5V$	2		$V_{CC} + 1$	V
V_{IL2}	Input Low Voltage	$1.8V \leq V_{CC} < 4.5V$	0		$V_{CC} \times 0.2$	V
V_{IH2}	Input High Voltage	$1.8V \leq V_{CC} < 4.5V$	$V_{CC} \times 0.7$		$V_{CC} + 1$	V
V_{OL1}	Output Low Voltage	$4.5V \leq V_{CC} < 5.5V$ $I_{OL} = 2.1mA$			0.4	V
V_{OH1}	Output High Voltage	$4.5V \leq V_{CC} < 5.5V$ $I_{OH} = -400\mu A$	2.4			V
V_{OL2}	Output Low Voltage	$1.8V \leq V_{CC} < 4.5V$ $I_{OL} = 1mA$			0.2	V
V_{OH2}	Output High Voltage	$1.8V \leq V_{CC} < 4.5V$ $I_{OH} = -100\mu A$	$V_{CC} - 0.2$			V

Note:

- (1) The minimum DC input voltage is $-0.5V$. During transitions, inputs may undershoot to $-2.0V$ for periods of less than 20 ns. Maximum DC voltage on output pins is $V_{CC} + 0.5V$, which may overshoot to $V_{CC} + 2.0V$ for periods of less than 20 ns.
- (2) Output shorted for no more than one second. No more than one output shorted at a time.
- (3) This parameter is tested initially and after a design or process change that affects the parameter.
- (4) Latch-up protection is provided for stresses up to 100 mA on address and data pins from $-1V$ to $V_{CC} + 1V$.

PIN CAPACITANCE

Symbol	Test	Conditions	Min	Typ	Max	Units
C _{OUT} ⁽¹⁾	Output Capacitance (DO)	V _{OUT} =0V			5	pF
C _{IN} ⁽¹⁾	Input Capacitance (CS, SK, DI, ORG)	V _{IN} =0V			5	pF

INSTRUCTION SET

Instruction	Start Bit	Opcode	Address		Data		Comments
			x8	x16	x8	x16	
READ	1	10	A6-A0	A5-A0			Read Address AN– A0
ERASE	1	11	A6-A0	A5-A0			Clear Address AN– A0
WRITE	1	01	A6-A0	A5-A0	D7-D0	D15-D0	Write Address AN– A0
EWEN	1	00	11XXXXX	11XXXX			Write Enable
EWDS	1	00	00XXXXX	00XXXX			Write Disable
ERAL	1	00	10XXXXX	10XXXX			Clear All Addresses
WRAL	1	00	01XXXXX	01XXXX	D7-D0	D15-D0	Write All Addresses

A.C. CHARACTERISTICS

Symbol	Parameter	Test Conditions	Limits						Units
			V _{CC} = 1.8V-6V		V _{CC} = 2.5V-6V		V _{CC} = 4.5V-5.5V		
			Min	Max	Min	Max	Min	Max	
t _{CS}	CS Setup Time	C _L = 100pF (3)	200		100		50		ns
t _{CSH}	CS Hold Time		0		0		0		ns
t _{DIS}	DI Setup Time		400		200		100		ns
t _{DIH}	DI Hold Time		400		200		100		ns
t _{PD1}	Output Delay to 1			1		0.5		0.25	μs
t _{PD0}	Output Delay to 0			1		0.5		0.25	μs
t _{HZ} ⁽¹⁾	Output Delay to High-Z			400		200		100	ns
t _{EW}	Program/Erase Pulse Width			10		10		10	ms
t _{CSMIN}	Minimum CS Low Time		1		0.5		0.25		μs
t _{SKHI}	Minimum SK High Time		1		0.5		0.25		μs
t _{SKLOW}	Minimum SK Low Time		1		0.5		0.25		μs
t _{SV}	Output Delay to Status Valid			1		0.5		0.25	μs
SK _{MAX}	Maximum Clock Frequency		DC	250	DC	500	DC	1000	kHz

POWER-UP TIMING (1)(2)

Symbol	Parameter	Max	Units
t _{PUR}	Power-up to Read Operation	1	ms
t _{PUW}	Power-up to Write Operation	1	ms

A.C. TEST CONDITIONS

Input Rise and Fall Times	≤ 50ns	
Input Pulse Voltages	0.4V to 2.4V	4.5V ≤ V _{CC} ≤ 5.5V
Timing Reference Voltages	0.8V, 2.0V	4.5V ≤ V _{CC} ≤ 5.5V
Input Pulse Voltages	0.2V _{CC} to 0.7V _{CC}	1.8V ≤ V _{CC} ≤ 4.5V
Timing Reference Voltages	0.5V _{CC}	1.8V ≤ V _{CC} ≤ 4.5V

NOTE:

- (1) This parameter is tested initially and after a design or process change that affects the parameter.
- (2) t_{PUR} and t_{PUW} are the delays required from the time V_{CC} is stable until the specified operation can be initiated.
- (3) The input levels and timing reference points are shown in "AC Test Conditions" table.

DEVICE OPERATION

The CAT93C46R is a 1024-bit nonvolatile memory intended for use with industry standard microprocessors. The CAT93C46R can be organized as either registers of 16 bits or 8 bits. When organized as X16, seven 9-bit instructions control the reading, writing and erase operations of the device. When organized as X8, seven 10-bit instructions control the reading, writing and erase operations of the device. The CAT93C46R operates on a single power supply and will generate on chip, the high voltage required during any write operation.

Instructions, addresses, and write data are clocked into the DI pin on the rising edge of the clock (SK). The DO pin is normally in a high impedance state except when reading data from the device, or when checking the ready/busy status after a write operation.

The ready/busy status can be determined after the start of a write operation by selecting the device (CS high) and polling the DO pin; DO low indicates that the write operation is not completed, while DO high indicates that the device is ready for the next instruction. If necessary, the DO pin may be placed back into a high impedance state during chip select by shifting a dummy "1" into the DI pin. The DO pin will enter the high impedance state on the falling edge of the clock (SK). Placing the DO pin into the high impedance state is recommended in applications where the DI pin and the DO pin are to be tied together to form a common DI/O pin.

The format for all instructions sent to the device is a logical "1" start bit, a 2-bit (or 4-bit) opcode, 6-bit address (an additional bit when organized X8) and for write operations a 16-bit data field (8-bit for X8 organizations).

Read

Upon receiving a READ command and an address (clocked into the DI pin), the DO pin of the CAT93C46R will come out of the high impedance state and, after sending an initial dummy zero bit, will begin shifting out the data addressed (MSB first). The output data bits will toggle on the rising edge of the SK clock and are stable after the specified time delay (t_{PD0} or t_{PD1}).

Write

After receiving a WRITE command, address and the data, the CS (Chip Select) pin must be deselected for a minimum of t_{CSMIN}. The falling edge of CS will start the self clocking clear and data store cycle of the memory location specified in the instruction. The clocking of the SK pin is not necessary after the device has entered the self clocking mode. The ready/busy status of the CAT93C46R can be determined by selecting the device and polling the DO pin. Since this device features Auto-Clear before write, it is NOT necessary to erase a memory location before it is written into.

Figure 1. Synchronous Data Timing

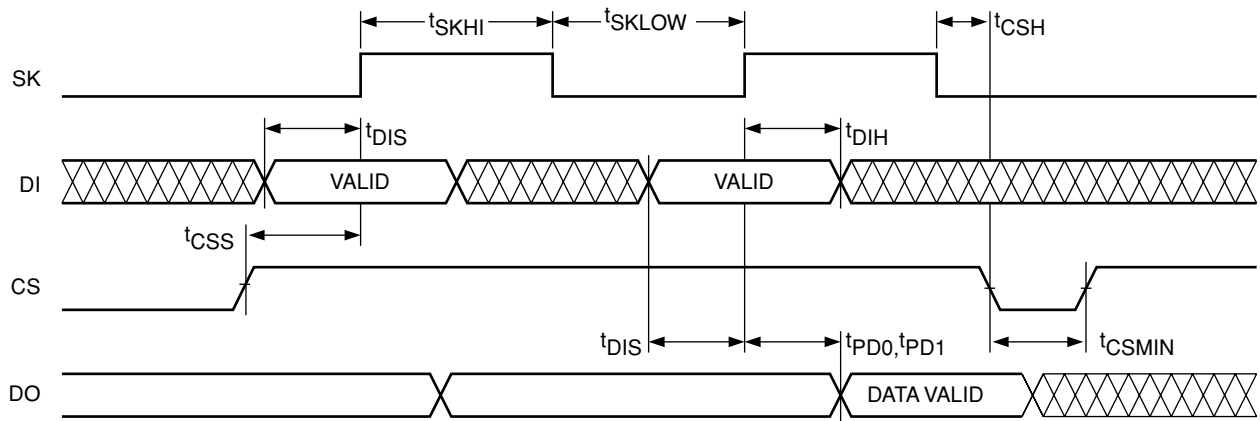

Figure 2. Read Instruction Timing

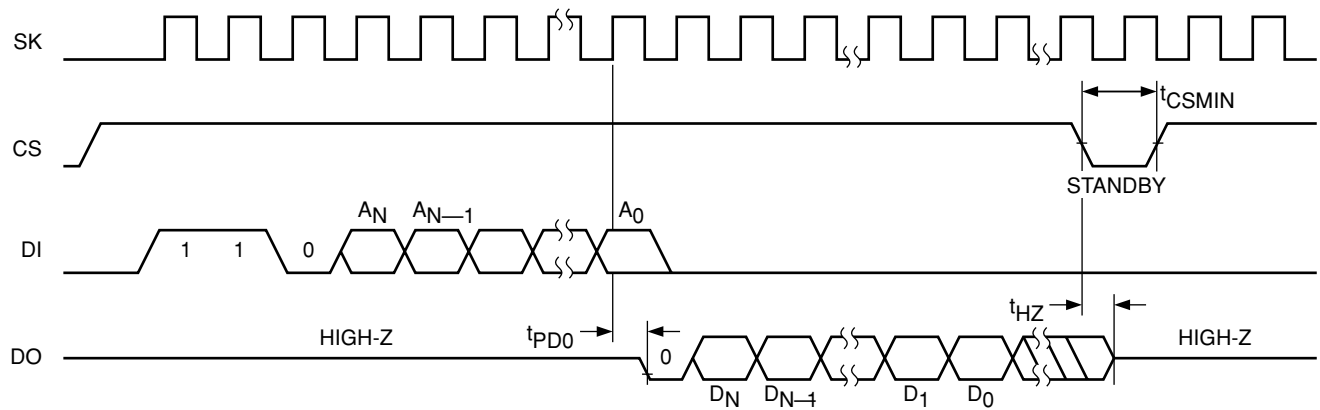
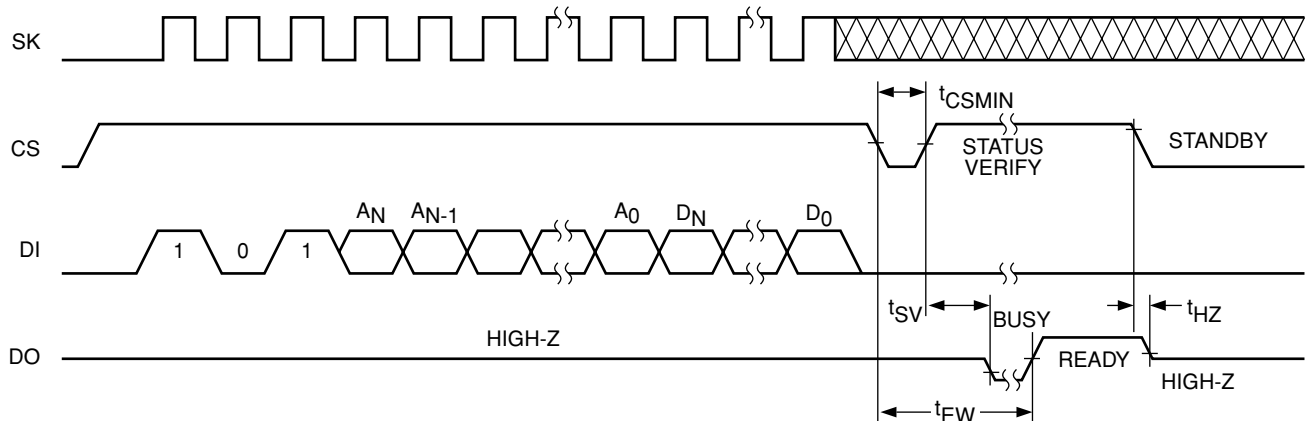

Figure 3. Write Instruction Timing



Erase

Upon receiving an ERASE command and address, the CS (Chip Select) pin must be deasserted for a minimum of t_{CSMIN} . The falling edge of CS will start the self clocking clear cycle of the selected memory location. The clocking of the SK pin is not necessary after the device has entered the self clocking mode. The ready/busy status of the CAT93C46R can be determined by selecting the device and polling the DO pin. Once cleared, the content of a cleared location returns to a logical “1” state.

Erase/Write Enable and Disable

The CAT93C46R powers up in the write disable state. Any writing after power-up or after an EWDS (write disable) instruction must first be preceded by the EWEN (write enable) instruction. Once the write instruction is enabled, it will remain enabled until power to the device is removed, or the EWDS instruction is sent. The EWDS instruction can be used to disable all CAT93C46R write and clear instructions, and will prevent any accidental writing or clearing of the device. Data can be read normally from the device regardless of the write enable/disable status.

Erase All

Upon receiving an ERAL command, the CS (Chip Select) pin must be deselected for a minimum of t_{CSMIN} . The falling edge of CS will start the self clocking clear cycle of all memory locations in the device. The clocking of the SK pin is not necessary after the device has entered the self clocking mode. The ready/busy status of the CAT93C46R can be determined by selecting the device and polling the DO pin. Once cleared, the contents of all memory bits return to a logical “1” state.

Write All

Upon receiving a WRAL command and data, the CS (Chip Select) pin must be deselected for a minimum of t_{CSMIN} . The falling edge of CS will start the self clocking data write to all memory locations in the device. The clocking of the SK pin is not necessary after the device has entered the self clocking mode. (Note 1.) The ready/busy status of the CAT93C46R can be determined by selecting the device and polling the DO pin. It is not necessary for all memory locations to be cleared before the WRAL command is executed.

Note:

- (1) With CAT93C46R, after the last data bit has been sampled, Chip Select (CS) must be brought Low before the next rising edge of the clock(SK) in order to start the self-timed high voltage cycle. This is important because if the CS is brought low before or after this specific frame window, the addressed location will not be programmed or erased.

Figure 4. Erase Instruction Timing

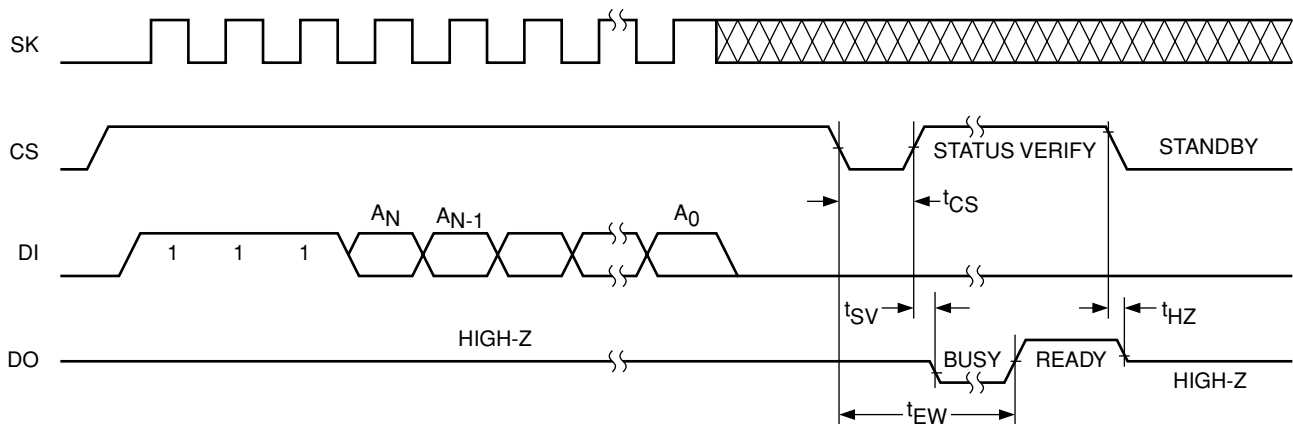

Figure 5. EWEN/EWDS Instruction Timing

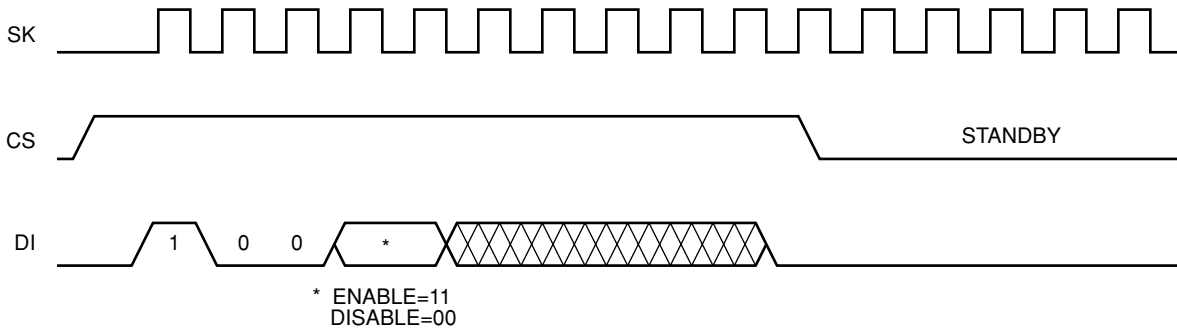

Figure 6. ERAL Instruction Timing

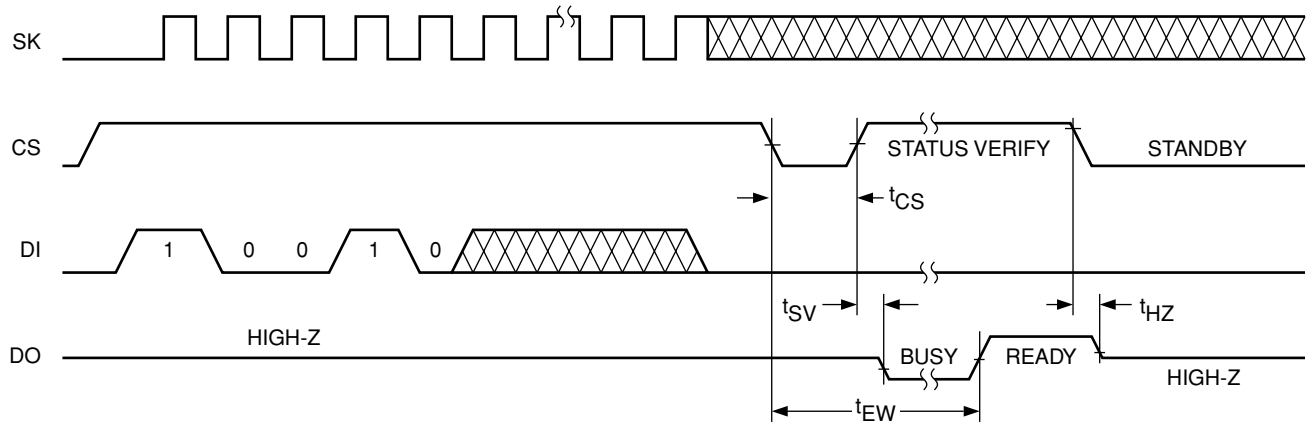
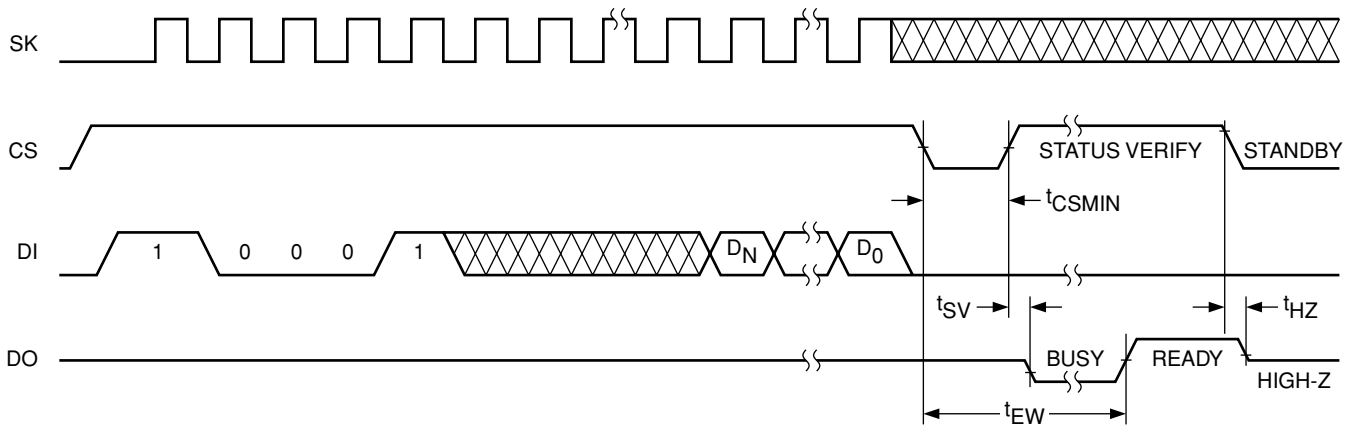
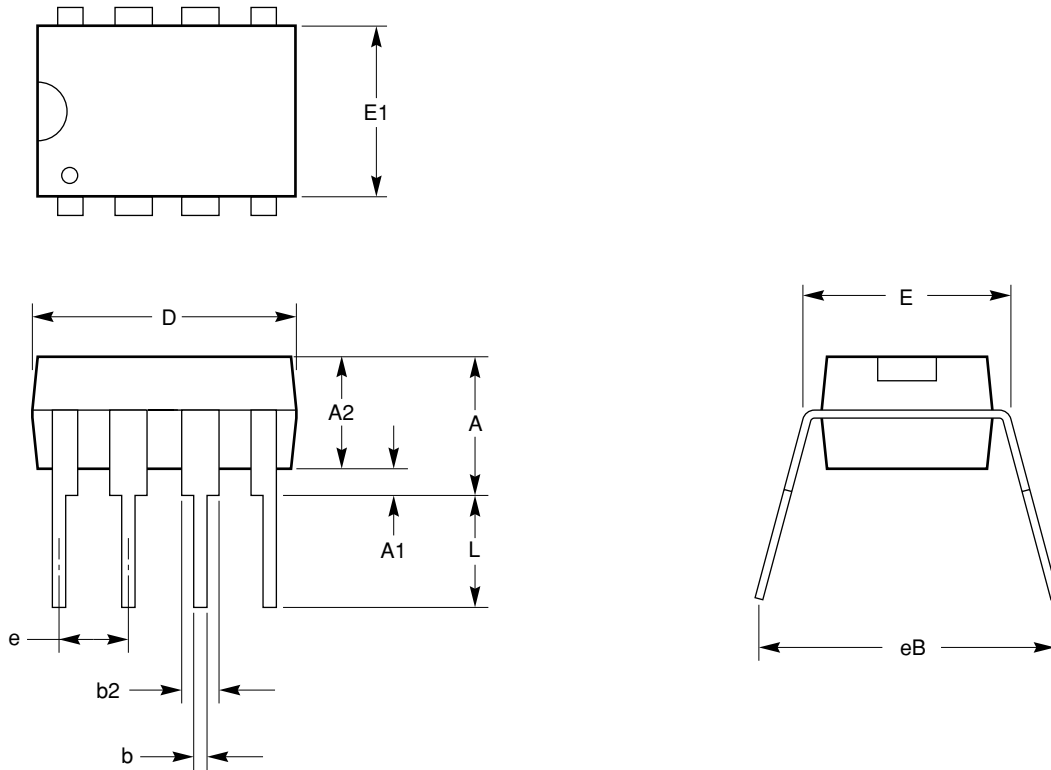

Figure 7. WRAL Instruction Timing



8-LEAD 300 MIL WIDE PLASTIC DIP (L)



SYMBOL	MIN	NOM	MAX
A	0.120		0.210
A1	0.015		
A2	0.115	0.130	0.195
b	0.014	0.018	0.022
b2	0.045	0.060	0.070
D	0.355	0.365	0.400
D2	0.300		0.325
E	0.300	0.310	0.325
E1	0.240	0.250	0.280
e		0.100 BSC	
eB			0.430
L	0.115	0.130	0.150

24C02_8-LEAD_DIP_(300P).eps

Notes:

1. Complies with JEDEC Standard MS001.
2. All dimensions are in inches.
3. Dimensioning and tolerancing per ANSI Y14.5M-1982

8-LEAD 150 MIL WIDE SOIC (V, W)

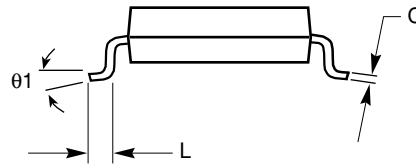
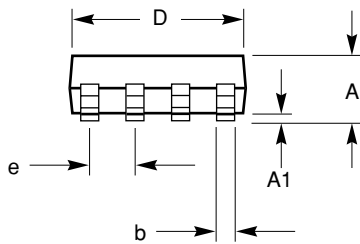
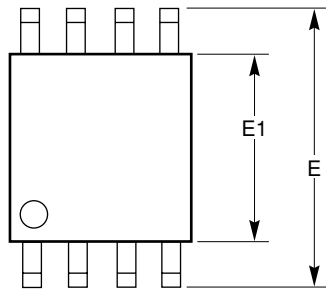

SYMBOL	MIN	NOM	MAX
A1	0.0040		0.0098
A2	0.0532		0.0688
b	0.013		0.020
C	0.0075		0.0098
D	0.1890		0.1968
E	0.2284		0.2440
E1	0.149		0.1574
e		0.050 BSC	
f	0.0099		0.0196
θ_1	0°		8°

24C02_8-LEAD_SOIC.eps

Notes:

1. Complies with JEDEC specification MS-012 dimensions.
2. All linear dimensions in millimeters.

8-LEAD TSSOP (Y)

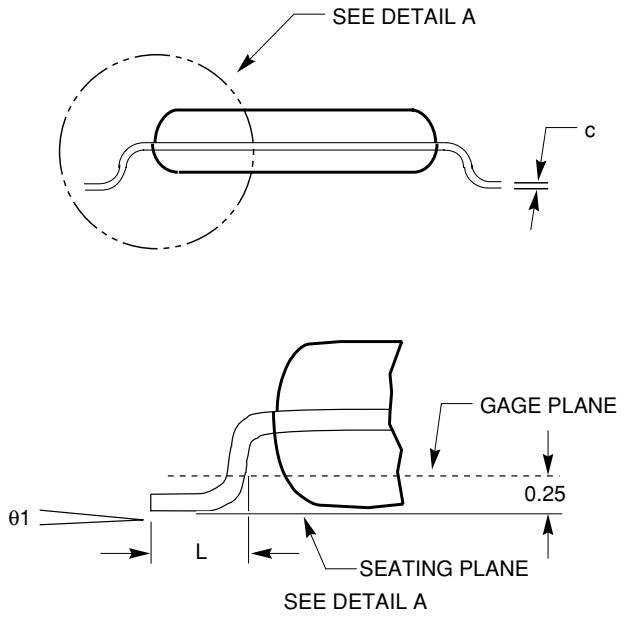
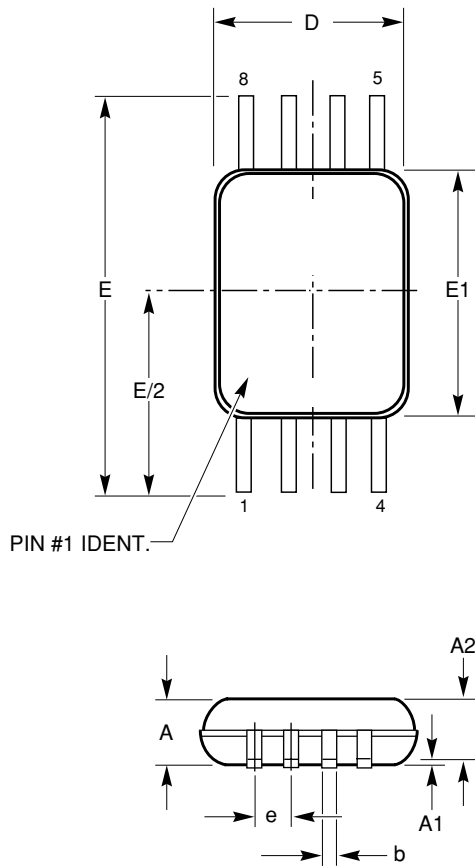

SYMBOL	MIN	NOM	MAX
A			1.20
A1	0.05		0.15
A2	0.80	0.90	1.05
b	0.19		0.30
c	0.09		0.20
D	2.90	3.00	3.10
E	6.30	6.4	6.50
E1	4.30	4.40	4.50
e		0.65 BSC	
L	0.50	0.60	0.75
θ1	0.00		8.00

Notes:

1. All dimensions in millimeters.

8-PAD TDFN 3X3 PACKAGE (ZD4)

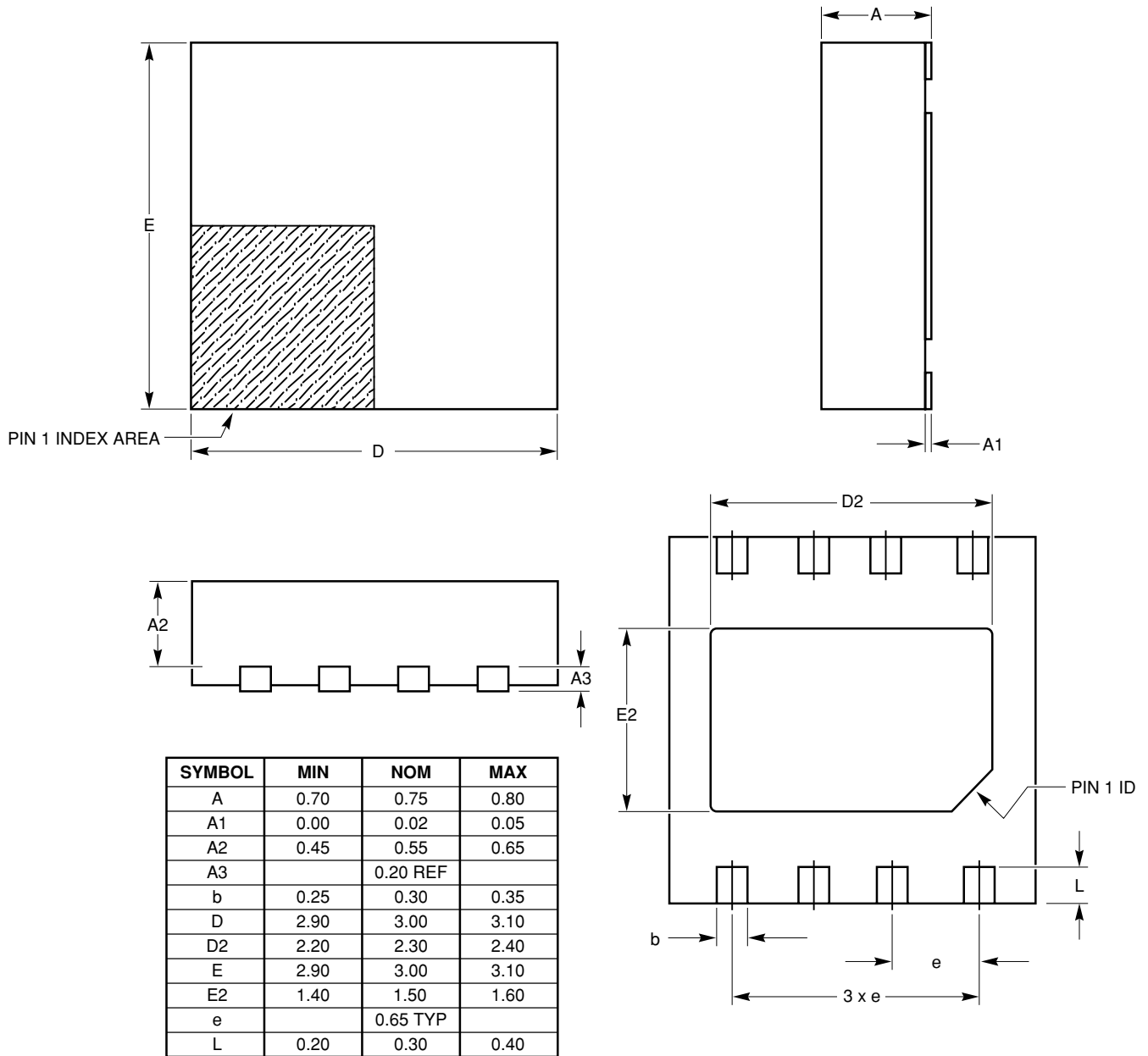

NOTE:

1. ALL DIMENSIONS IN MM. ANGLES IN DEGREES.
2. COPLANARITY SHALL NOT EXCEED 0.08 mm.
3. WARPAGE SHALL NOT EXCEED 0.10 mm.
4. PACKAGE LENGTH / PACKAGE WIDTH ARE CONSIDERED AS SPECIAL CHARACTERISTIC.
5. REFER JEDEC MO-229 / WEEC

TDFN3X3 (01).eps

ORDERING INFORMATION

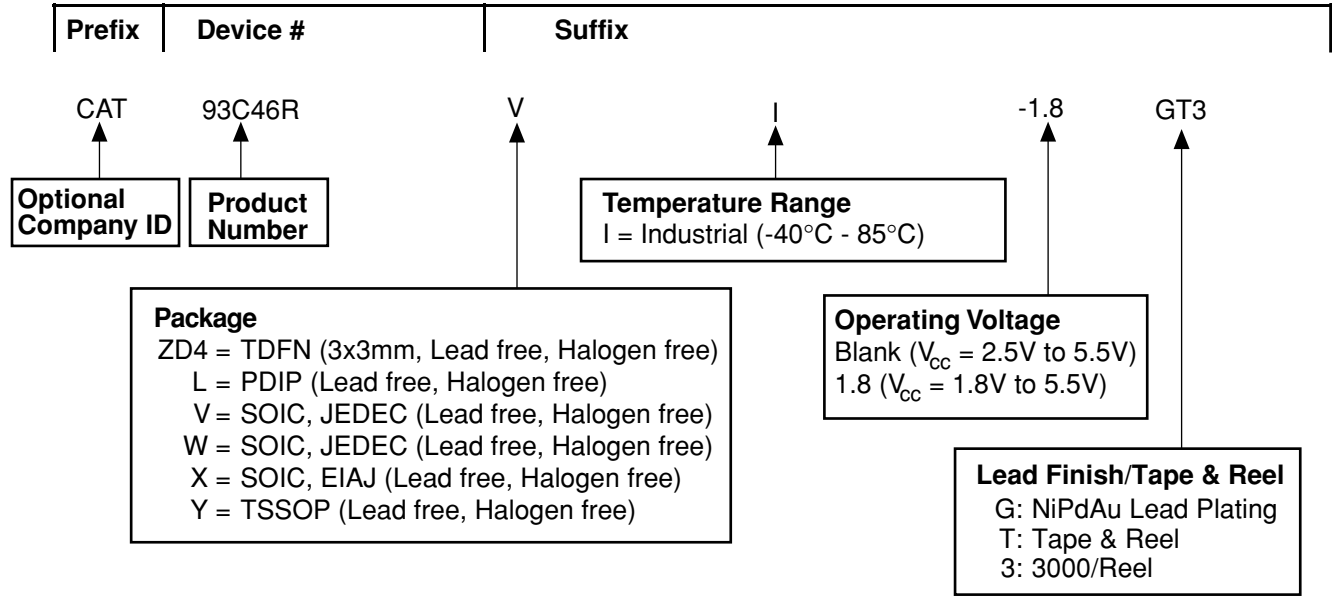

Notes:

(1) The device used in the above example is a CAT93C46VI-1.8GT3 (SOIC, Industrial Temperature, 1.8 Volt to 5.5 Volt Operating Voltage, Tape & Reel)

PACKAGE MARKING

8-Lead PDIP

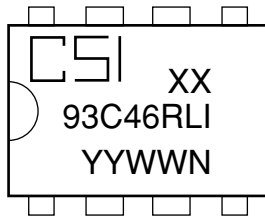

CSI = Catalyst Semiconductor, Inc.
 93C46RL = Device Code
 I = Temperature Range
 YY = Production Year
 WW = Production Week
 N = Product Revision
 XX = Voltage Range
 1.8V - 5.5V = 18
 2.5V - 5.5V = Blank

8-Lead SOIC

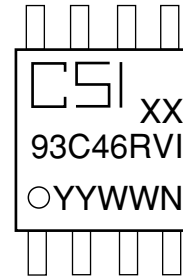

CSI = Catalyst Semiconductor, Inc.
 93C46V = Device Code
 I = Temperature Range
 YY = Production Year
 WW = Production Week
 N = Product Revision
 XX = Voltage Range
 1.8V - 5.5V = 18
 2.5V - 5.5V = Blank

8-Lead TSSOP

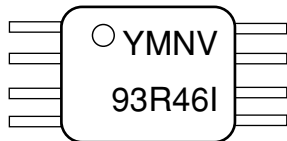

Y = Production Year
 M = Production Month
 N = Die Revision
 93R46 = Device Code
 I = Industrial Temperature Range
 V = Voltage Range
 1.8V - 5.5V = 8
 2.5V - 5.5V = Blank

8-Lead TDFN

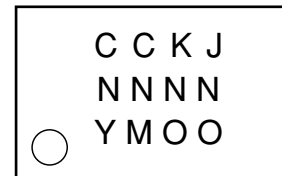

CCKJ = Device Code
 NNNN = Traceability Code
 Y = Production Year
 M = Production Month
 OO = Origin Country

TAPE AND REEL

Direction of Feed

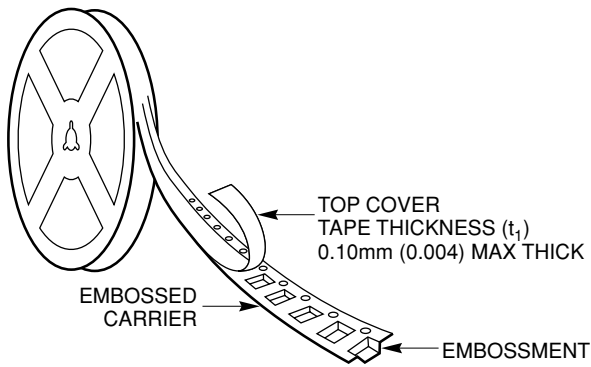

Device Orientation

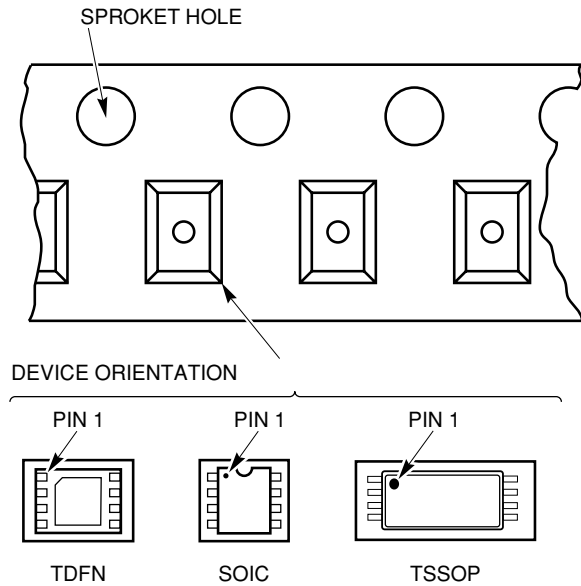

Reel Dimensions⁽¹⁾

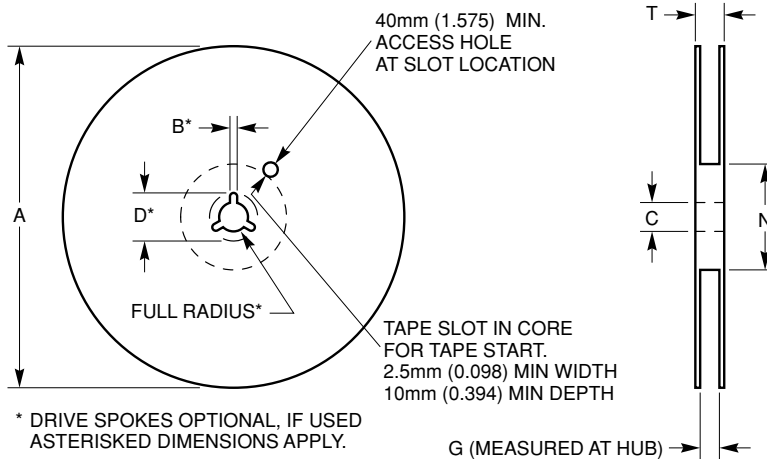

Embossed Carrier Dimensions

TAPE SIZE	A		B MIN	C	D* MIN	N MIN	G	T MAX
	MAX	QTY/REEL						
8MM	330 (13.00)	3000	1.5 (0.059)	12.80 (0.504) 13.20 (0.5200)	20.2 (0.795)	50 (1.969)	8.4 (0.328)	14.4
							9.9 (0.389)	0.566
12MM							12.4 (0.488)	18.4
							14.4 (0.558)	(0.724)

Component/Tape Size Cross-Reference

Component	Package Type	Tape Size (W)	Part Pitch (P)
8L SOIC	J, S, W, V	12mm	8mm
8L TDFN 2x3xmm	SP2, VP2	8mm	4mm

Notes:

(1) Metric dimensions will govern; English measurements rounded, for reference only and in parentheses.

Embossed Carrier Dimensions (12 Pape Only)

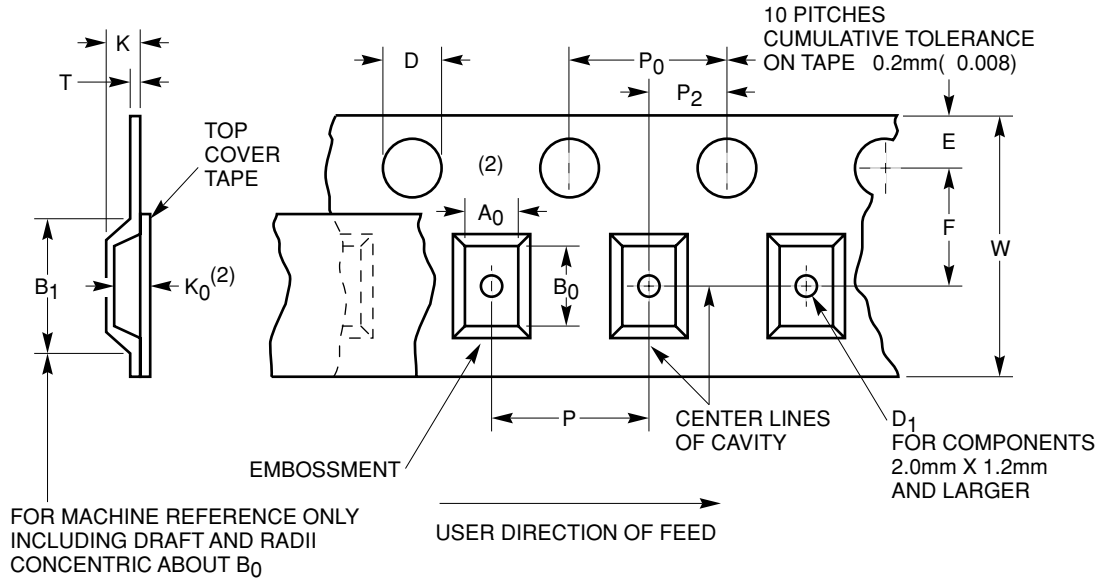

Embossed Tape—Constant Dimensions⁽¹⁾

Tape Sizes	D	E	P ₀	T Max.	D1 Min.	A ₀ B ₀ K ₀ ⁽²⁾
12mm	<u>1.5 (0.059)</u>	<u>1.65 (0.065)</u>	<u>3.9 (0.153)</u>	400 (0.016)	1.5 (0.059)	
	1.6 (0.063)	1.85 (0.073)	4.1 (0.161)			

Embossed Tape—Variable Dimensions⁽¹⁾

Tape Sizes	B ₁ Max.	F	K Max.	P ₂	R Min.	W	P
12mm	8.2 (0.0323)	<u>5.45 (0.0215)</u>	4.5 (0.177)	<u>1.95 (0.077)</u>	30 (1.181)	<u>11.7 (0.460)</u>	<u>7.9 (0.275)</u>
		5.55 (0.0219)		2.05 (0.081)		12.3 (0.484)	8.1 (0.355)

Note:

(1) Metric dimensions will govern; English measurements rounded, for reference only and in parentheses.

(2) A₀ B₀ K₀ are determined by component size. The clearance between the component and the cavity must be within 0.05 (0.002) min. to 0.65 (0.026) max. for 12mm tape, 0.05 (0.002) min. to 0.90 (0.035) max. for 16mm tape, and 0.05 (0.002) min. to 1.00 (0.039) max. for 24mm tape and larger. The component cannot rotate more than 20° within the determined cavity, see Component Rotation.

REVISION HISTORY

Date	Revision	Comments
12/01/05	A	Initial Issue
12/07/05	B	Update D.C. Operating Characteristics
12/14/05	C	Update Pin Functions Update Ordering Information

Copyrights, Trademarks and Patents

Trademarks and registered trademarks of Catalyst Semiconductor include each of the following:

DPP™ AE²™

Catalyst Semiconductor has been issued U.S. and foreign patents and has patent applications pending that protect its products. For a complete list of patents issued to Catalyst Semiconductor contact the Company's corporate office at 408.542.1000.

CATALYST SEMICONDUCTOR MAKES NO WARRANTY, REPRESENTATION OR GUARANTEE, EXPRESS OR IMPLIED, REGARDING THE SUITABILITY OF ITS PRODUCTS FOR ANY PARTICULAR PURPOSE, NOR THAT THE USE OF ITS PRODUCTS WILL NOT INFRINGE ITS INTELLECTUAL PROPERTY RIGHTS OR THE RIGHTS OF THIRD PARTIES WITH RESPECT TO ANY PARTICULAR USE OR APPLICATION AND SPECIFICALLY DISCLAIMS ANY AND ALL LIABILITY ARISING OUT OF ANY SUCH USE OR APPLICATION, INCLUDING BUT NOT LIMITED TO, CONSEQUENTIAL OR INCIDENTAL DAMAGES.

Catalyst Semiconductor products are not designed, intended, or authorized for use as components in systems intended for surgical implant into the body, or other applications intended to support or sustain life, or for any other application in which the failure of the Catalyst Semiconductor product could create a situation where personal injury or death may occur.

Catalyst Semiconductor reserves the right to make changes to or discontinue any product or service described herein without notice. Products with data sheets labeled "Advance Information" or "Preliminary" and other products described herein may not be in production or offered for sale.

Catalyst Semiconductor advises customers to obtain the current version of the relevant product information before placing orders. Circuit diagrams illustrate typical semiconductor applications and may not be complete.



Catalyst Semiconductor, Inc.

Corporate Headquarters

1250 Borregas Avenue

Sunnyvale, CA 94089

Phone: 408.542.1000

Fax: 408.542.1200

www.catalyst-semiconductor.com

Publication #: 1107

Revision: C

Issue date: 12/14/05