

CAT24LC02/CAT24LC02I

2K-Bit SERIAL E²PROM

FEATURES

- I²C Bus Compatible*
- Low Power CMOS Technology
- Hardware Write Protect
- 8 Byte Page Write Buffer
- Self-Timed Write Cycle with Auto-Clear
- 100,000 Program/Erase Cycles
- 100 Year Data Retention
- 8 pin DIP, 8 pin SO or 14 pin SO Package
- 3 to 6 Volt Operation
- ZERO Power™ Version (CAT24LC02Z) Available
- Optional High Endurance Device Available

2

DESCRIPTION

The CAT24LC02/CAT24LC02I is a 2K bit Serial CMOS E²PROM internally organized as 256 x 8 bits. Catalyst's advanced CMOS technology substantially reduces device power requirements. The CAT24LC02/CAT24LC02I

features an 8-byte page write buffer and a special write protection feature. The device operates via the I²C bus serial interface and is available in 8 pin DIP, 8 pin SO or 14 pin SO packages.

PIN CONFIGURATION

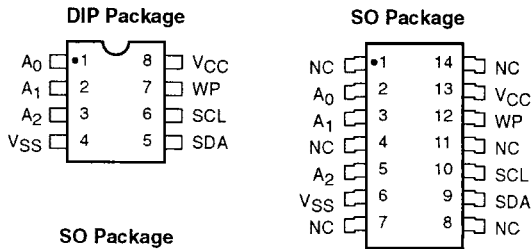

5021 FHD F01

PIN FUNCTIONS

Pin Name	Function
A0, A1, A2	Device Address Inputs
SDA	Serial Data/Address
SCL	Serial Clock
WP	Write Protect
V _{CC}	+3V to +6V Power Supply
V _{SS}	Ground

BLOCK DIAGRAM

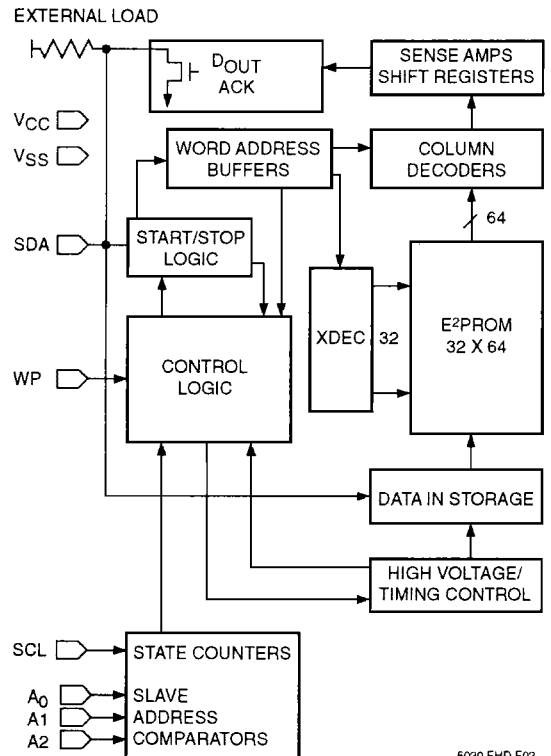

5020 FHD F02

* Catalyst Semiconductor is licensed by Philips Corporation to carry the I²C Bus Protocol.

ABSOLUTE MAXIMUM RATINGS*

Temperature Under Bias	-55°C to +125°C
Storage Temperature	-65°C to +150°C
Voltage on Any Pin with Respect to Ground ⁽¹⁾	-2.0V to +V _{CC} + 2.0V
V _{CC} with Respect to Ground	-2.0V to +7.0V
Package Power Dissipation Capability (T _A = 25°C)	1.0W
Lead Soldering Temperature (10 secs)	300°C
Output Short Circuit Current ⁽²⁾	100mA

***COMMENT**

Stresses above those listed under "Absolute Maximum Ratings" may cause permanent damage to the device. These are stress ratings only, and functional operation of the device at these or any other conditions outside of those listed in the operational sections of this specification is not implied. Exposure to any absolute maximum rating for extended periods may affect device performance and reliability.

RELIABILITY CHARACTERISTICS

Symbol	Parameter	Min.	Max.	Units	Reference Test Method
N _{END} ⁽³⁾	Endurance	100,000		Cycles/Byte	MIL-STD-883, Test Method 1033
T _{DR} ⁽³⁾	Data Retention	100		Years	MIL-STD-883, Test Method 1008
V _{ZAP} ⁽³⁾	ESD Susceptibility	2000		Volts	MIL-STD-883, Test Method 3015
I _{LTH} ⁽³⁾⁽⁴⁾	Latch-up	100		mA	JEDEC Standard 17

D.C. OPERATING CHARACTERISTICS

CAT24LC02 T_A = 0°C to +70°C, V_{CC} = +3V to +6V, unless otherwise specified.

CAT24LC02I T_A = -40°C to +85°C, V_{CC} = +3V to +6V, unless otherwise specified.

Symbol	Parameter	Limits			Units	Test Conditions
		Min.	Typ.	Max.		
I _{CC}	Power Supply Current			3	mA	f _{SCL} = 100 KHz
I _{SB}	Standby Current V _{CC} = 6V			4	μA	V _{IN} = GND or V _{CC}
I _{SBZ} ⁽⁵⁾	Standby Current V _{CC} = 6V			0	μA	V _{IN} = GND or V _{CC}
I _{LI}	Input Leakage Current			10	μA	V _{IN} = GND to V _{CC}
I _{LO}	Output Leakage Current			10	μA	V _{OUT} = GND to V _{CC}
V _{IL}	Input Low Voltage	-1.0		V _{CC} x 0.3	V	
V _{IH}	Input High Voltage	V _{CC} x 0.7		V _{CC} + 0.5	V	
V _{OL}	Output Low Voltage			0.4	V	I _{OL} = 3 mA

CAPACITANCE T_A = 25°C, f = 1.0 MHz, V_{CC} = 5V

Symbol	Test	Max.	Units	Conditions
C _{I/O} ⁽³⁾	Input/Output Capacitance (SDA)	8	pF	V _{I/O} = 0V
C _{IN} ⁽³⁾	Input Capacitance (A0, A1, A2, SCL)	6	pF	V _{IN} = 0V

Note:

- (1) The minimum DC input voltage is -0.5V. During transitions, inputs may undershoot to -2.0V for periods of less than 20 ns. Maximum DC voltage on output pins is V_{CC} + 0.5V, which may overshoot to V_{CC} + 2.0V for periods of less than 20ns.
- (2) Output shorted for no more than one second. No more than one output shorted at a time.
- (3) This parameter is tested initially and after a design or process change that affects the parameter.
- (4) Latch-up protection is provided for stresses up to 100 mA on address and data pins from -1V to V_{CC} + 1V.
- (5) Standby Current (I_{SBZ}) = 0μA (<900nA) for the CAT24LC02Z.

A.C. CHARACTERISTICS

CAT24LC02 $T_A = 0^\circ\text{C}$ to $+70^\circ\text{C}$, $V_{CC} = +3\text{V}$ to $+6\text{V}$, unless otherwise specified.

CAT24LC02I $T_A = -40^\circ\text{C}$ to $+85^\circ\text{C}$, $V_{CC} = +3\text{V}$ to $+6\text{V}$, unless otherwise specified.

Read & Write Cycle Limits

Symbol	Parameter	Min.	Max	Units
F_{SCL}	Clock Frequency		100	KHz
$T_1^{(3)}$	Noise Suppression Time Constant at SCL, SDA Inputs		100	ns
t_{AA}	SCL Low to SDA Data Out and ACK Out		3.5	μs
$t_{BUF}^{(3)}$	Time the Bus Must be Free Before a New Transmission Can Start	4.7		μs
$t_{HD:STA}$	Start Condition Hold Time	4.0		μs
t_{LOW}	Clock Low Period	4.7		μs
t_{HIGH}	Clock High Period	4.0		μs
$t_{SU:STA}$	Start Condition Setup Time (for a Repeated Start Condition)	4.7		μs
$t_{HD:DAT}$	Data In Hold Time	0		ns
$t_{SU:DAT}$	Data In Setup Time	250		ns
$t_R^{(3)}$	SDA and SCL Rise Time		1	μs
$t_F^{(3)}$	SDA and SCL Fall Time		300	ns
$t_{SU:STO}$	Stop Condition Setup Time	4.7		μs
t_{DH}	Data Out Hold Time	300		ns

2

Power-Up Timing⁽³⁾⁽⁶⁾

Symbol	Parameter	Max.	Units
t_{PUR}	Power-up to Read Operation	1	ms
t_{PUW}	Power-up to Write Operation	1	ms

Write Cycle Limits

Symbol	Parameter	Min.	Typ.	Max	Units
t_{WR}	Write Cycle Time			10	ms

The write cycle time is the time from a valid stop condition of a write sequence to the end of the internal program/erase cycle. During the write cycle, the bus

interface circuits are disabled, SDA is allowed to remain high, and the device does not respond to its slave address.

Note:

(3) This parameter is tested initially and after a design or process change that affects the parameter.

(6) t_{PUR} and t_{PUW} are the delays required from the time V_{CC} is stable until the specified operation can be initiated.

FUNCTIONAL DESCRIPTION

The CAT24LC02/CAT24LC02I supports the I²C Bus data transmission protocol. This Inter-Integrated Circuit Bus protocol defines any device that sends data to the bus to be a transmitter and any device receiving data to be a receiver. The transfer is controlled by the Master device which generates the serial clock and all START and STOP conditions for bus access. The CAT24LC02/CAT24LC02I operates as a Slave device. Both the Master device and Slave device can operate as either transmitter or receiver, but the Master device controls which mode is activated. A maximum of 8 devices may be connected to the bus as determined by the device address inputs A0, A1, and A2.

PIN DESCRIPTIONS

SCL: Serial Clock

The serial clock input clocks all data transferred into or out of the device.

SDA: Serial Data/Address

The bidirectional serial data/address pin is used to transfer all data into and out of the device. The SDA pin is an open drain output and can be wire-ORed with other open drain or open collector outputs.

A0, A1, A2: Device Address Inputs

These inputs set the device address within the slave address. They must be connected to either V_{SS} or V_{CC}.

WP: Write Protect

If the WP pin is tied to V_{CC} the entire memory array becomes READ only. If the WP pin is tied to V_{SS} normal read/write operations are allowed to the device. This feature protects the device from inadvertent programming.

Figure 1. Bus Timing

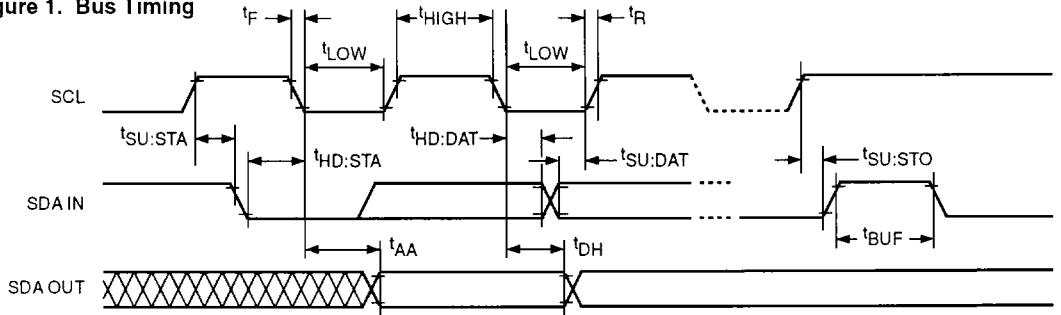

5020 FHD F03

Figure 2. Write Cycle Timing

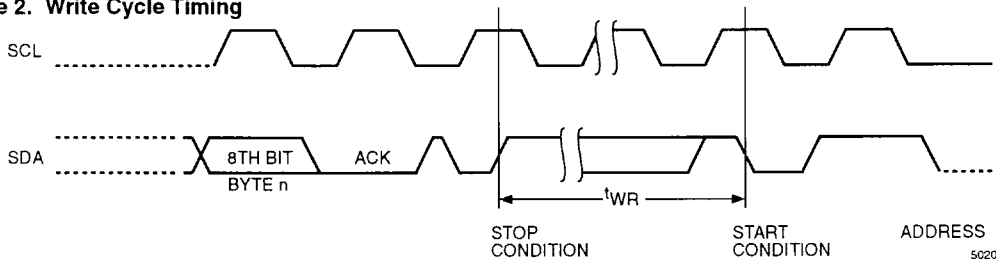

5020 FHD F04

Figure 3. Start/Stop Timing

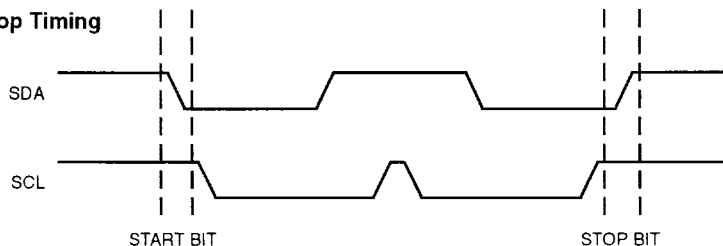

5020 FHD F05

I²C BUS PROTOCOL

The following defines the features of the I²C bus protocol:

- (1) Data transfer may be initiated only when the bus is not busy.
- (2) During a data transfer, the data line must remain stable whenever the clock line is high. Any changes in the data line while the clock line is high will be interpreted as a START or STOP condition.

START Condition

The START Condition precedes all commands to the device, and is defined as a HIGH to LOW transition of SDA when SCL is HIGH. The CAT24LC02/CAT24LC02I monitors the SDA and SCL lines and will not respond until this condition is met.

STOP Condition

A LOW to HIGH transition of SDA when SCL is HIGH determines the STOP condition. All operations must end with a STOP condition.

DEVICE ADDRESSING

The bus Master begins a transmission by sending a START condition. The Master then sends the address of the particular slave device it is requesting. The four most significant bits of the 8-bit slave address are fixed as 1010 for the CAT24LC02/CAT24LC02I (see Fig. 5). The next three significant bits (A2, A1, A0) are the device address bits and define which device the Master is

accessing. Up to eight CAT24LC02/CAT24LC02I devices may be individually addressed by the system. The last bit of the slave address specifies whether a Read or Write operation is to be performed. When this bit is set to 1, a Read operation is selected, and when set to 0, a Write operation is selected.

After the Master sends a START condition, the CAT24LC02/CAT24LC02I monitors the bus and responds with an acknowledge (on the SDA line) when its address matches the transmitted slave address. The CAT24LC02/CAT24LC02I then performs a Read or Write operation depending on the state of the R/W bit.

2

Acknowledge

After a successful data transfer, each receiving device is required to generate an acknowledge. The Acknowledging device pulls down the SDA line during the ninth clock cycle, signaling that it received the eight bits of data.

The CAT24LC02/CAT24LC02I responds with an acknowledge after receiving a START condition and its slave address. If the device has been selected along with a write operation, it responds with an acknowledge after receiving each eight bit byte.

When the CAT24LC02/CAT24LC02I begins a READ mode it transmits eight bits of data, releases the SDA line, and monitors the line for an acknowledge. Once it receives this acknowledge, the CAT24LC02/CAT24LC02I will continue to transmit data. If no acknowledge is sent by the Master, the device terminates data transmission and waits for a STOP condition.

Figure 4. Acknowledge Timing

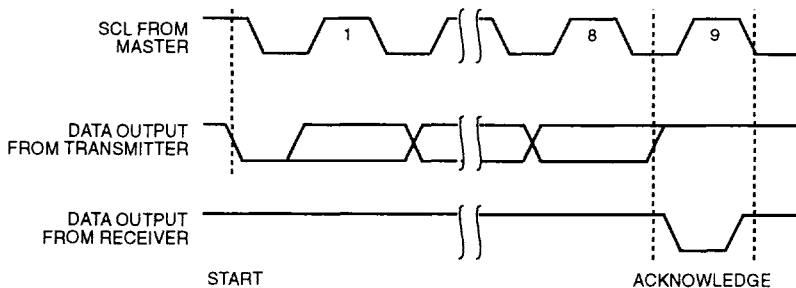

5020 FHD F06

Figure 5. Slave Address Bits

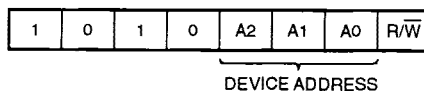

5022 FHD F07

WRITE OPERATIONS

Byte Write

In the Byte Write mode, the Master device sends the START condition and the slave address information (with the R/W bit set to zero) to the Slave device. After the Slave generates an acknowledge, the Master sends the byte address that is to be written into the address pointer of the CAT24LC02/CAT24LC02I. After receiving another acknowledge from the Slave, the Master device transmits the data byte to be written into the addressed memory location. The CAT24LC02/CAT24LC02I acknowledges once more and the Master generates the STOP condition, at which time the device begins its internal programming cycle to nonvolatile memory. While this internal cycle is in progress, the device will not respond to any request from the Master device.

Page Write

The CAT24LC02/CAT24LC02I writes up to 8 bytes of data, in a single write cycle, using the Page Write operation. The page write operation is initiated in the same manner as the byte write operation, however instead of terminating after the initial word is transmitted, the Master is allowed to send up to 7 additional bytes. After each byte has been transmitted the CAT24LC02/

CAT24LC02I will respond with an acknowledge, and internally increment the three low order address bits by one. The high order bits remain unchanged.

If the Master transmits more than 8 bytes prior to sending the STOP condition, the address counter 'wraps around', and previously transmitted data will be overwritten.

Once all eight bytes are received and the STOP condition has been sent by the Master, the internal programming cycle begins. At this point all received data is written to the CAT24LC02/CAT24LC02I in a single write cycle.

Acknowledge Polling

The disabling of the inputs can be used to take advantage of the typical write cycle time. Once the stop condition is issued to indicate the end of the host's write operation, the CAT24LC02/CAT24LC02I initiates the internal write cycle. ACK polling can be initiated immediately. This involves issuing the start condition followed by the slave address for a write operation. If the CAT24LC02/CAT24LC02I is still busy with the write operation, no ACK will be returned. If the CAT24LC02/CAT24LC02I has completed the write operation, an ACK will be returned and the host can then proceed with the next read or write operation.

Figure 6. Byte Write Timing

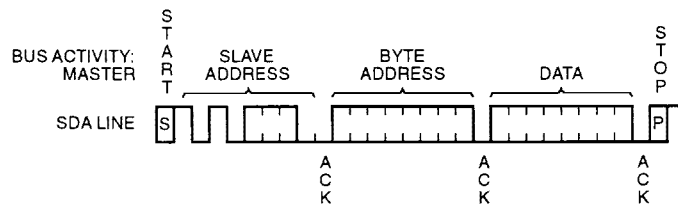

5020 FHD F08

Figure 7. Page Write Timing

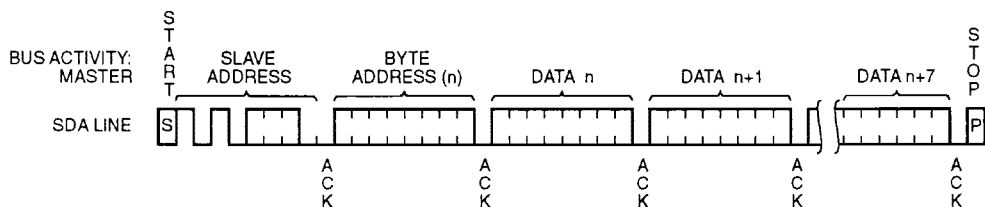

NOTE: IN THIS EXAMPLE n = XXXX 0000(B); X = 1 or 0

5020 FHD F09

WRITE PROTECTION

The Write Protection feature allows the user to protect against inadvertent programming of the memory array. If the WP pin is tied to V_{CC} , the entire memory array is protected and becomes read only. The CAT24LC02/CAT24LC02I will accept both slave and byte addresses, but the memory location accessed is protected from programming by the device's failure to send an acknowledge after the first byte of data is received.

READ OPERATIONS

The READ operation for the CAT24LC02/CAT24LC02I is initiated in the same manner as the write operation with the one exception that the R/W bit is set to a one. Three different READ operations are possible: Immediate Address READ, Selective READ and Sequential READ.

Immediate Address Read

The CAT24LC02/CAT24LC02I's address counter contains the address of the last byte accessed, incremented by one. In other words, if the last READ or WRITE access was to address N, the READ immediately following would access data from address N+1. If N=255, then the counter will 'wrap around' to address 0 and continue to clock out data. After the CAT24LC02/CAT24LC02I receives its slave address information (with the R/W bit set to one), it issues an acknowledge, then transmits the eight bit byte requested. The master device does not send an acknowledge but will generate a STOP condition.

Selective Read

Selective READ operations allow the Master device to select at random any memory location for a READ operation. The Master device first performs a 'dummy' write operation by sending the START condition, slave address and byte address of the location it wishes to read. After the CAT24LC02/CAT24LC02I acknowledges the word address, the Master device resends the START condition and the slave address, this time with the R/W bit set to one. The CAT24LC02/CAT24LC02I then responds with its acknowledge and sends the eight bit byte requested. The master device does not send an acknowledge but will generate a STOP condition.

2

Sequential Read

The Sequential READ operation can be initiated by either the Immediate Address READ or Selective READ operations. After the CAT24LC02/CAT24LC02I sends the initial eight bit byte requested, the Master will respond with an acknowledge which tells the device it requires more data. The CAT24LC02/CAT24LC02I will continue to output an eight bit byte for each acknowledge sent by the Master. The operation will terminate when the Master fails to respond with an acknowledge, thus sending the STOP condition.

The data being transmitted from the CAT24LC02/CAT24LC02I is outputted sequentially with data from address N followed by data from address N+1. The READ operation address counter increments all of the CAT24LC02/CAT24LC02I address bits so that the entire memory array can be read during one operation. If more than the 256 bytes are read out, the counter will "wrap around" and continue to clock out data bytes.

Figure 8. Immediate Address Read Timing

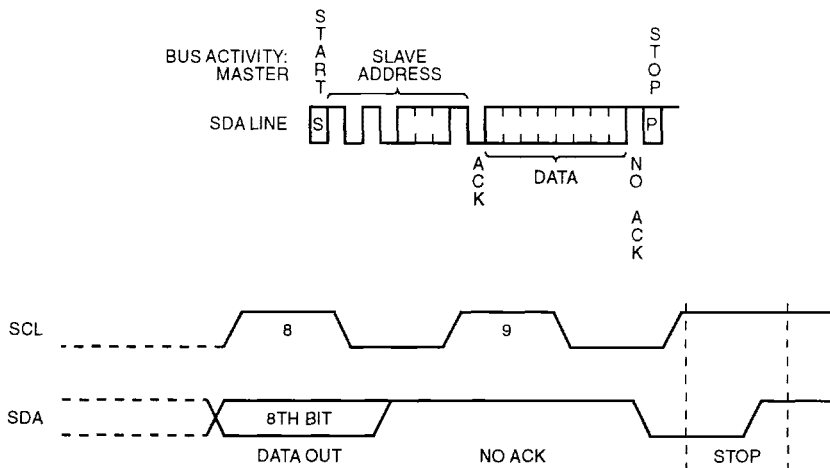

5020 FHD F10

Figure 9. Selective Read Timing

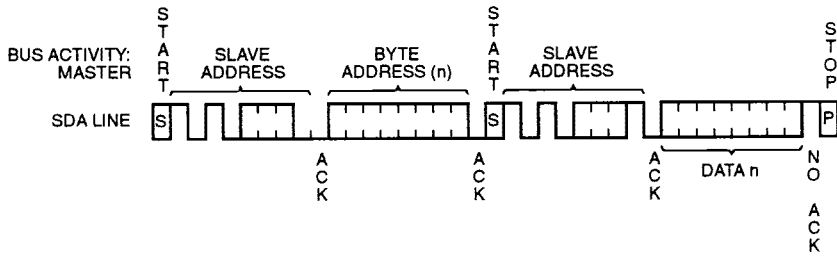

5020 FHD F11

Figure 10. Sequential Read Timing

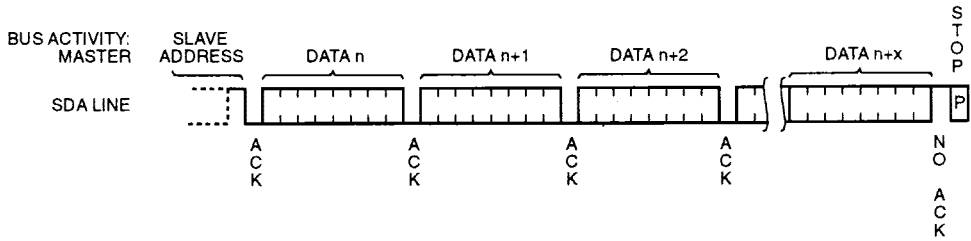

5020 FHD F12