

Fast CMOS 16-Bit Transparent Latch
Features

- High-speed, low power device with high current drive
- $V_{CC} = 5V \pm 10\%$
- Hysteresis on all inputs
- Supports Live Insertion
- Balanced output drivers: ± 24 mA
- Reduced system switching noise
- Typical V_{OLP} (Output Ground Bounce) $< 0.6V$ at $V_{CC} = 5V$, $T_A = 25^\circ C$
- Packaging:
 - 48-pin 240-mil wide plastic TSSOP (A)
 - 48-pin 300-mil wide SSOP (V)

Description

Pericom Semiconductor's PI74FCT162373T is a 16-bit transparent latch designed with 3-state outputs and is intended for bus oriented applications. The Output Enable and Latch Enable controls are organized to operate as two 8-bit latches or one 16-bit latch. When Latch Enable (LE) is HIGH, the flip-flops appear transparent to the data. The data that meets the set-up time when LE is LOW is latched. When OE is HIGH, the bus output is in the high impedance state.

The PI74FCT162373T has ± 24 mA balanced output drivers. It is designed with current limiting resistors at its outputs to control the output edge rate resulting in lower ground bounce and undershoot. This eliminates the need for external terminating resistors for most interface applications.

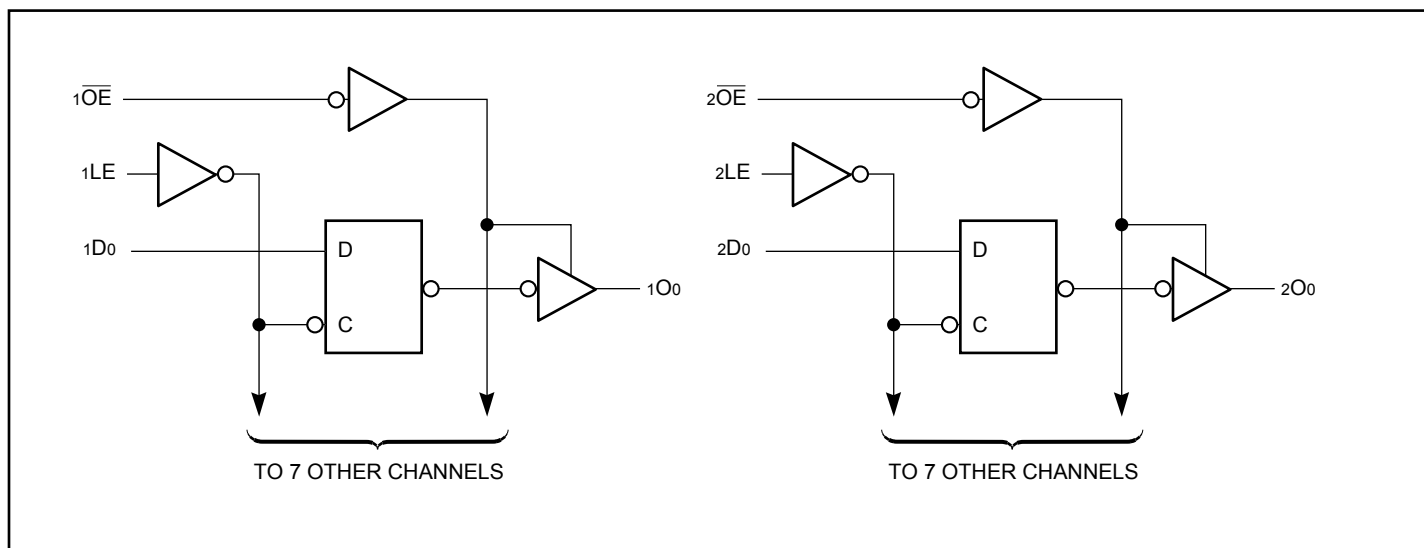
Block Diagram

Pin Description

Pin Name	Description
\overline{xOE}	Output Enable Inputs (Active LOW)
xLE	Latch Enable Inputs (Active HIGH)
xDx	Inputs ⁽¹⁾
xOx	3-State Outputs
GND	Ground
VCC	Power

Note:

- For the PI74FCT162H373T, these pins have "Bus Hold."
All other pins are standard, outputs, or I/Os.

Truth Table

Inputs ⁽¹⁾			Outputs ⁽¹⁾
xDx	\overline{xOE}	xLE	xOx
H	L	H	H
L	L	H	L
X	H	X	Z

Notes

- H = High Voltage Level
X = Don't Care
L = Low Voltage Level
Z = High Impedance

Pin Configuration

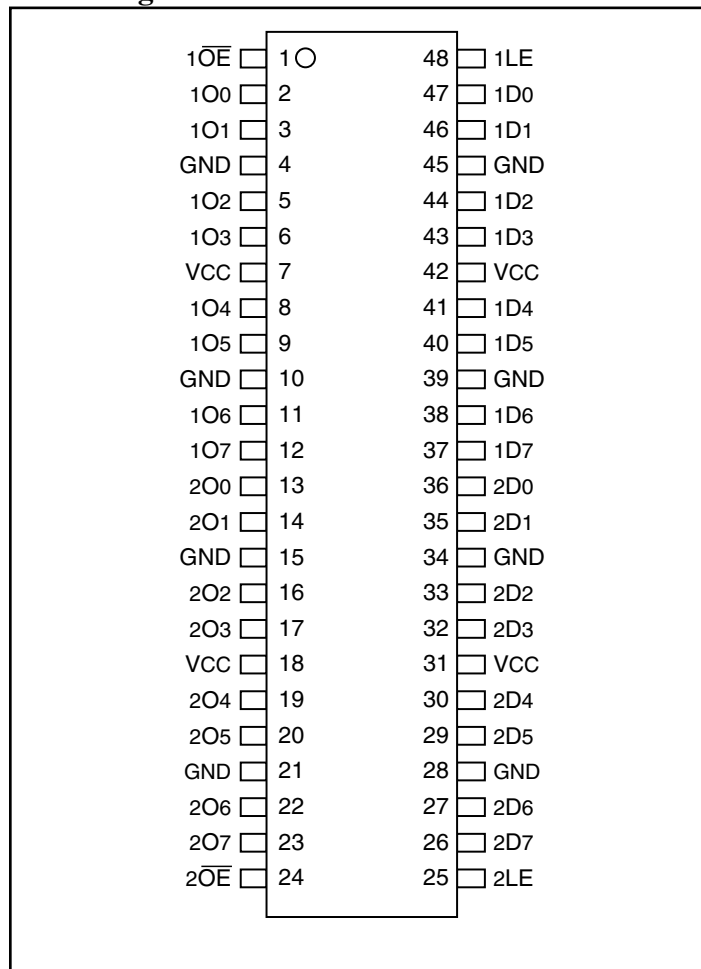

Maximum Ratings

(Above which the useful life may be impaired. For user guidelines, not tested.)

Storage Temperature	-65°C to +150°C
Ambient Temperature with Power Applied	-40°C to +85°C
Supply Voltage to Ground Potential (Inputs & V _{CC} Only)...	-0.5V to +7.0V
Supply Voltage to Ground Potential (Outputs & D/O Only)	-0.5V to +7.0V
DC Input Voltage	-0.5V to +7.0V
DC Output Current.....	120 mA
Power Dissipation	1.0W

Note:

Stresses greater than those listed under MAXIMUM RATINGS may cause permanent damage to the device. This is a stress rating only and functional operation of the device at these or any other conditions above those indicated in the operational sections of this specification is not implied. Exposure to absolute maximum rating conditions for extended periods may affect reliability.

DC Electrical Characteristics (Over the Operating Range, T_A = -40°C to +85°C, V_{CC} = 5.0V ± 10%)

Parameters	Description	Test Conditions ⁽¹⁾	Min.	Typ ⁽²⁾	Max.	Units	
V _{IH}	Input HIGH Voltage	Guaranteed Logic HIGH Level	2.0			V	
V _{IL}	Input LOW Voltage	Guaranteed Logic LOW Level			0.8		
I _{IH}	Input HIGH Current	Standard Input, V _{CC} = Max.			1	μA	
I _{IH}	Input HIGH Current	Standard I/O, V _{CC} = Max.			1		
I _{IH}	Input HIGH Current	Bus Hold Input ⁽⁴⁾ , V _{CC} = Max.			±100		
I _{IH}	Input HIGH Current	Bus Hold I/O ⁽⁴⁾ , V _{CC} = Max.			±100		
I _{IL}	Input LOW Current	Standard Input, V _{CC} = Min.			-1		
I _{IL}	Input LOW Current	Standard I/O, V _{CC} = Min.			-1		
I _{IL}	Input LOW Current	Bus Hold Input ⁽⁴⁾ , V _{CC} = Min.			±100		
I _{IL}	Input LOW Current	Bus Hold I/O ⁽⁴⁾ , V _{CC} = Min.			±100		
I _{BHH}	Bus Hold	Bus Hold Input ⁽⁴⁾ , V _{CC} = Min.	V _{IN} = 2.0V	-50			
I _{BHL}	Sustain Current		V _{IN} = 0.8V	+50			
I _{OZH} ⁽⁵⁾	High Impedance	V _{CC} = Max.	V _{OUT} = 2.7V		1		μA
I _{OZL} ⁽⁵⁾	Output Current	V _{CC} = Max.	V _{OUT} = 0.5V		-1		
V _{IK}	Clamp Diode Voltage	V _{CC} = Min., I _{IN} = -18mA		-0.7	-1.2	V	
I _{OS}	Short Circuit Current	V _{CC} = Max. ⁽³⁾ , V _{OUT} = GND	-80	-140	-200	mA	
I _O	Output Drive Current	V _{CC} = Max. ⁽³⁾ , V _{OUT} = 2.5V	-50		-180		
V _H	Input Hysteresis			100		mV	

Notes:

- For Max. or Min. conditions, use appropriate value specified under Electrical Characteristics for the applicable device type.
- Typical values are at V_{CC} = 5.0V, +25°C ambient and maximum loading.
- Not more than one output should be shorted at one time. Duration of the test should not exceed one second.
- Pins with Bus Hold are identified in the pin description.
- This specification does not apply to bi-directional functionalities with Bus Hold.

Power Supply Characteristics

Parameters	Description	Test Conditions ⁽¹⁾		Min.	Typ ⁽²⁾	Max.	Units
I_{CC}	Quiescent Power Supply Current	$V_{CC} = \text{Max.}$	$V_{IN} = \text{GND or } V_{CC}$		0.1	500	μA
ΔI_{CC}	Supply Current per Input @ TTL HIGH	$V_{CC} = \text{Max.}$	$V_{IN} = 3.4\text{V}^{(3)}$		0.5	1.5	mA
I_{CCD}	Supply Current per Input per MHz ⁽⁴⁾	$V_{CC} = \text{Max.}$, Outputs Open $x\overline{OE} = \text{GND}$, $xLE = V_{CC}$ One Bit Toggling 50% Duty Cycle	$V_{IN} = V_{CC}$ $V_{IN} = \text{GND}$		60	100	$\mu\text{A}/\text{MHz}$
I_C	Total Power Supply Current ⁽⁶⁾	$V_{CC} = \text{Max.}$, Outputs Open $f_i = 10 \text{ MHz}$ 50% Duty Cycle $x\overline{OE} = \text{GND}$, $xLE = V_{CC}$ One Bit Toggling	$V_{IN} = V_{CC}$ $V_{IN} = \text{GND}$		0.6	1.5 ⁽⁵⁾	mA
			$V_{IN} = 3.4\text{V}$ $V_{IN} = \text{GND}$		0.9	2.3 ⁽⁵⁾	
		$V_{CC} = \text{Max.}$, Outputs Open $f_i = 2.5 \text{ MHz}$ 50% Duty Cycle $x\overline{OE} = \text{GND}$, $xLE = V_{CC}$ 16 Bits Toggling	$V_{IN} = V_{CC}$ $V_{IN} = \text{GND}$		2.4	4.5 ⁽⁵⁾	
			$V_{IN} = 3.4\text{V}$ $V_{IN} = \text{GND}$		6.4	16.5 ⁽⁵⁾	

Notes:

- For Max. or Min. conditions, use appropriate value specified under Electrical Characteristics for the applicable device.
- Typical values are at $V_{CC} = 5.0\text{V}$, $+25^\circ\text{C}$ ambient.
- Per TTL driven input ($V_{IN} = 3.4\text{V}$); all other inputs at V_{CC} or GND.
- This parameter is not directly testable, but is derived for use in Total Power Supply Calculations.
- Values for these conditions are examples of the I_{CC} formula. These limits are guaranteed but not tested.
- $I_C = I_{\text{QUIESCENT}} + I_{\text{INPUTS}} + I_{\text{DYNAMIC}}$
 $I_C = I_{CC} + \Delta I_{CC} D_H N_T + I_{CCD} (f_{CP}/2 + f_i N_i)$
 I_{CC} = Quiescent Current
 ΔI_{CC} = Power Supply Current for a TTL High Input ($V_{IN} = 3.4\text{V}$)
 D_H = Duty Cycle for TTL Inputs High
 N_T = Number of TTL Inputs at D_H
 I_{CCD} = Dynamic Current Caused by an Input Transition Pair (HLH or LHL)
 f_{CP} = Clock Frequency for Register Devices (Zero for Non-Register Devices)
 f_i = Input Frequency
 N_i = Number of Inputs at f_i
 All currents are in milliamps and all frequencies are in megahertz.

Output Drive Characteristics (Over the Operating Range)

Parameters	Description	Test Conditions ⁽¹⁾		Min.	Typ ⁽²⁾	Max.	Units
V _{OH}	Output HIGH Voltage	V _{CC} = Min., V _{IN} = V _{IH} or V _{IL}	I _{OH} = -24mA	2.4	3.3		V
V _{OL}	Output LOW Voltage	V _{CC} = Min., V _{IN} = V _{IH} or V _{IL}	I _{OL} = 24mA		0.3	0.55	
I _{ODL}	Output LOW Current	V _{CC} = 5V, V _{IN} = V _{IH} OR V _{IL} , V _{OUT} = 1.5V ⁽³⁾		60	115	150	mA
I _{ODH}	Output HIGH Current	V _{CC} = 5V, V _{IN} = V _{IH} OR V _{IL} , V _{OUT} = 1.5V ⁽³⁾		-60	-115	-150	

Capacitance (T_A = 25°C, f = 1 MHz)

Parameters ⁽⁴⁾	Description	Test Conditions	Typ	Max.	Units
C _{IN}	Input Capacitance	V _{IN} = 0V	4.5	6	pF
C _{OUT}	Output Capacitance	V _{OUT} = 0V	5.5	8	

Notes:

- For Max. or Min. conditions, use appropriate value specified under Electrical Characteristics for the applicable device type.
- Typical values are at V_{CC} = 5.0V, +25°C ambient and maximum loading.
- Not more than one output should be shorted at one time. Duration of the test should not exceed one second.
- This parameter is determined by device characterization but is not production tested.

Switching Characteristics over Operating Range

Parameters	Description	Conditions ⁽¹⁾	162373T		162373AT		162373CT		Unit
			Com.		Com.	Com.	Com.	Com.	
			Min	Max	Min	Max	Min	Max	
t _{PLH} t _{PHL}	Propagation Delay xDx to xOx	C _L = 50pF R _L = 500Ω	1.5	8.0	1.5	5.2	1.5	4.2	ns
t _{PLH} t _{PHL}	Propagation Delay xLE to xOx		2.0	13.0	2.0	8.5	2.0	5.5	
t _{pZH} t _{pZL}	Output Enable Time xOE to xOx		1.5	12.0	1.5	6.5	1.5	5.5	
t _{PHZ} t _{PLZ}	Output Disable Time ⁽³⁾ xOE to xOx		1.5	7.5	1.5	5.5	1.5	5.0	
t _{SU}	Setup Time HIGH or LOW, xDx to xLE		2.0	—	2.0	—	2.0	—	
t _H	Hold Time HIGH or LOW, xDx to xLE		1.5	—	1.5	—	1.5	—	
t _w	xLE Pulse Width HIGH ⁽³⁾		6.0	—	5.0	—	5.0	—	
t _{SK(0)}	Output Skew ⁽⁴⁾		—	0.5	—	0.5	—	0.5	

Notes:

- See test circuit and waveforms.
- Minimum limits are guaranteed but not tested on Propagation Delays.
- This parameter is guaranteed but not production tested.
- Skew between any two outputs, of the same package, switching in the same direction. This parameter is guaranteed by design.

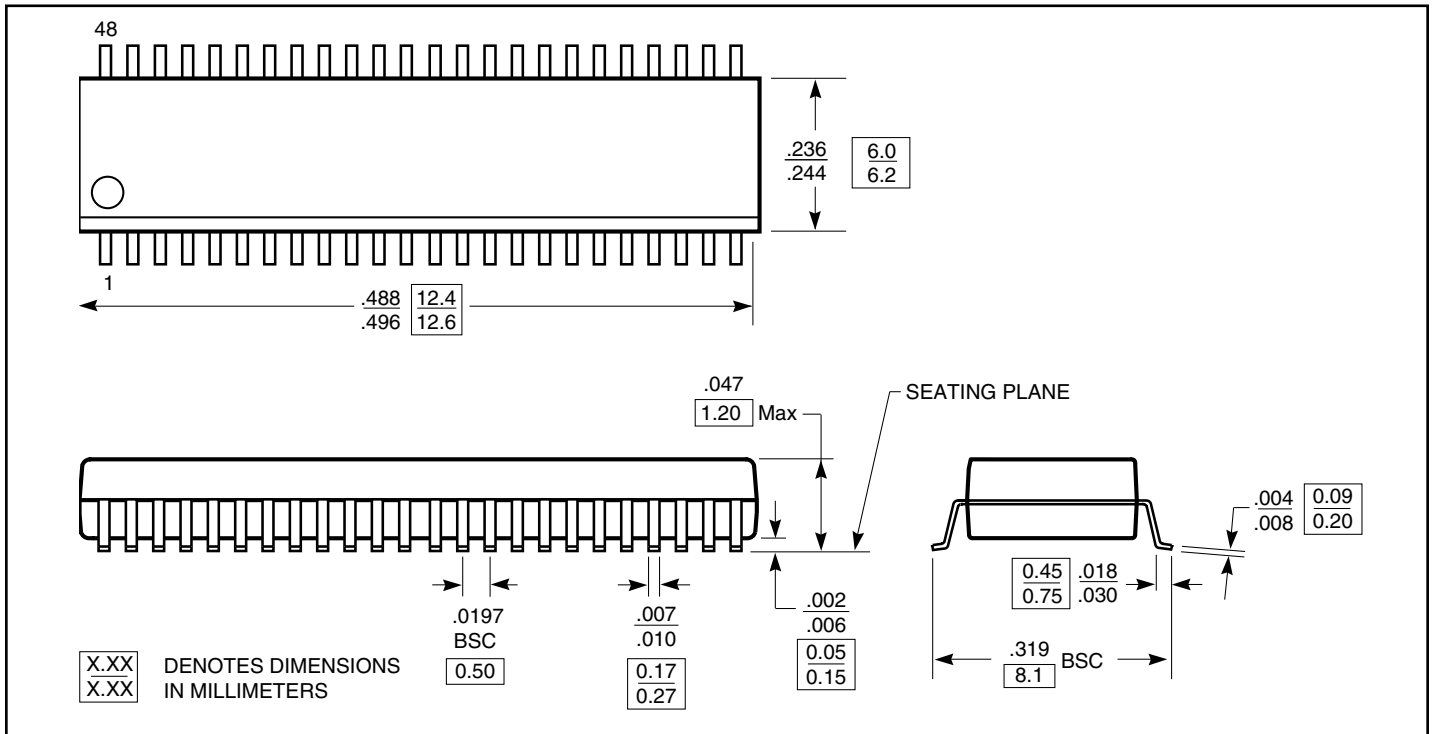
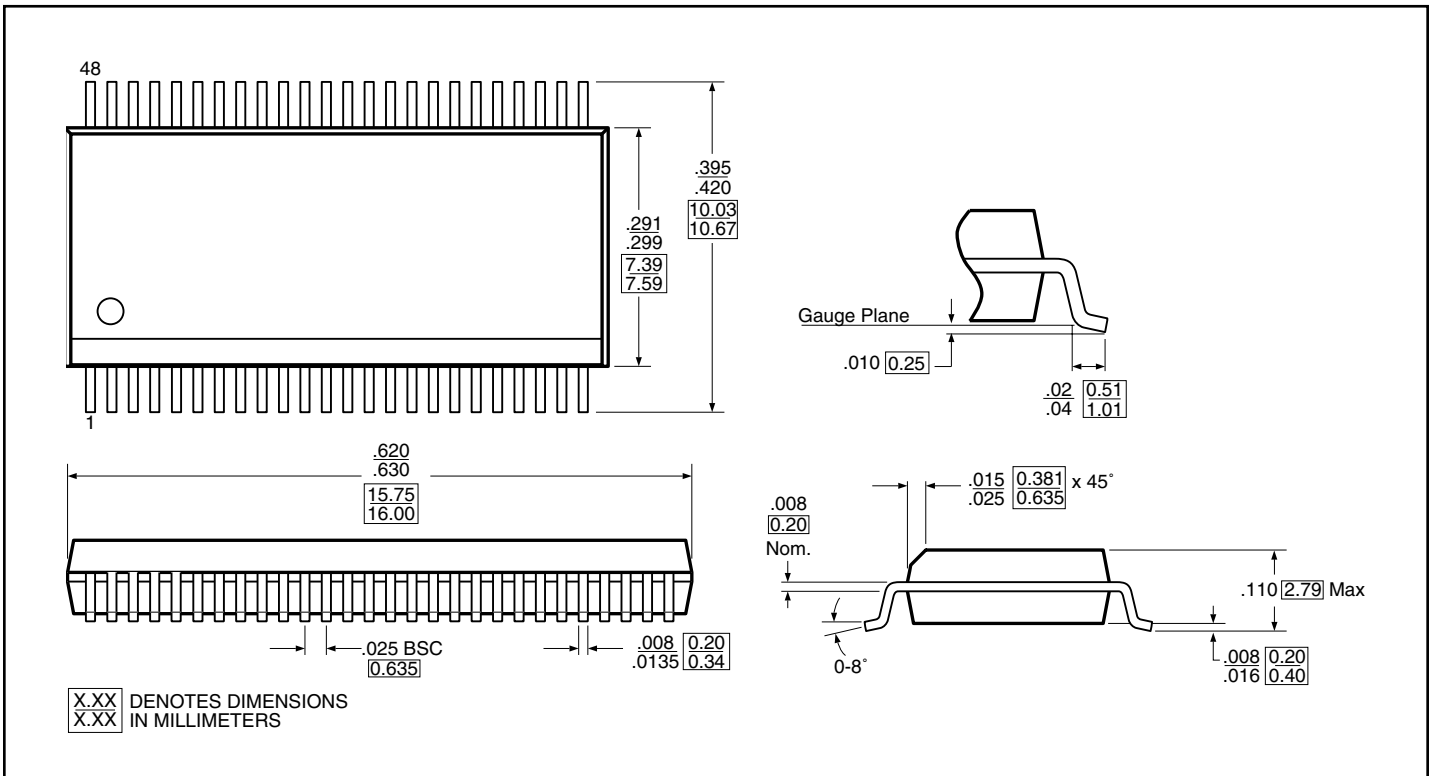
Packaging Mechanical: 48-pin 240-mil wide plastic TSSOP (A)

Packaging Mechanical: 48-pin 300-mil wide plastic SSOP (V)

Ordering Information

Ordering Code	Package Code	Speed Grade	Package Type
PI74FCT162373TA	A	Blank	48-pin 240-mil wide TSSOP
PI74FCT162373ATA	A	A	48-pin 240-mil wide TSSOP
PI74FCT162373CTA	A	C	48-pin 240-mil wide TSSOP
PI74FCT162373ATV	V	A	48-pin 300-mil wide SSOP

Notes:

1. Thermal characteristics can be found on the company web site at www.pericom.com/packaging/