

SN54HC393, SN74HC393 DUAL 4-BIT BINARY COUNTERS

SCLS143B – DECEMBER 1982 – REVISED MAY 1997

- Dual 4-Bit Binary Counters With Individual Clocks
- Direct Clear for Each 4-Bit Counter
- Can Significantly Improve System Densities by Reducing Counter Package Count by 50 Percent
- Package Options Include Plastic Small-Outline (D), Shrink Small-Outline (DB), and Ceramic Flat (W) Packages, Ceramic Chip Carriers (FK), and Standard Plastic (N) and Ceramic (J) 300-mil DIPs

description

The 'HC393 contain eight flip-flops and additional gating to implement two individual 4-bit counters in a single package. The 'HC393 comprise two independent 4-bit binary counters, each having a clear (CLR) and a clock (CLK) input. N-bit binary counters can be implemented with each package, providing the capability of divide by 256. The 'HC393 have parallel outputs from each counter stage so that any submultiple of the input count frequency is available for system timing signals.

The SN54HC393 is characterized for operation over the full military temperature range of -55°C to 125°C . The SN74HC393 is characterized for operation from -40°C to 85°C .

SN54HC393 . . . J OR W PACKAGE
SN74HC393 . . . D, DB, OR N PACKAGE
(TOP VIEW)

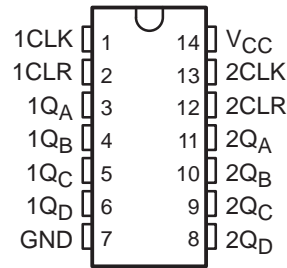

SN54HC393 . . . FK PACKAGE
(TOP VIEW)

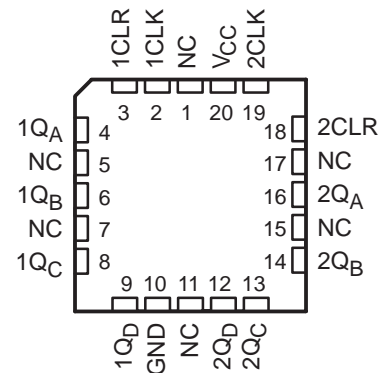

NC – No internal connection



Please be aware that an important notice concerning availability, standard warranty, and use in critical applications of Texas Instruments semiconductor products and disclaimers thereto appears at the end of this data sheet.

PRODUCTION DATA information is current as of publication date. Products conform to specifications per the terms of Texas Instruments standard warranty. Production processing does not necessarily include testing of all parameters.

 **TEXAS
INSTRUMENTS**

POST OFFICE BOX 655303 • DALLAS, TEXAS 75265

Copyright © 1997, Texas Instruments Incorporated

SN54HC393, SN74HC393 DUAL 4-BIT BINARY COUNTERS

SCLS143B – DECEMBER 1982 – REVISED MAY 1997

FUNCTION TABLE COUNT SEQUENCE
(each counter)

COUNT	OUTPUTS			
	Q _D	Q _C	Q _B	Q _A
0	L	L	L	L
1	L	L	L	H
2	L	L	H	L
3	L	L	H	H
4	L	H	L	L
5	L	H	L	H
6	L	H	H	L
7	L	H	H	H
8	H	L	L	L
9	H	L	L	H
10	H	L	H	L
11	H	L	H	H
12	H	H	L	L
13	H	H	L	H
14	H	H	H	L
15	H	H	H	H

logic symbol†

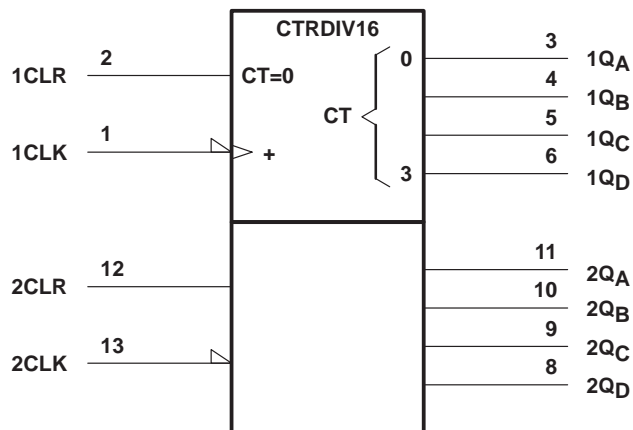

† This symbol is in accordance with ANSI/IEEE Std 91-1984 and IEC Publication 617-12. Pin numbers shown are for the D, DB, J, N, and W packages.

logic diagram, each counter (positive logic)

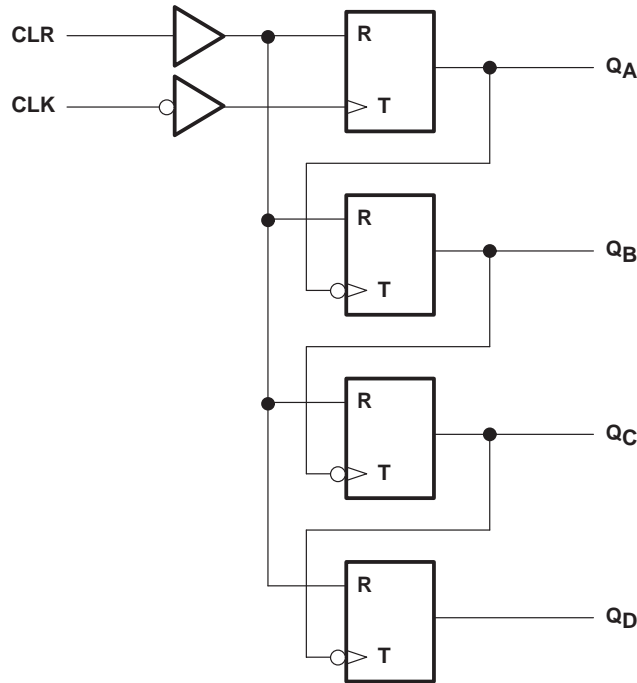

absolute maximum ratings over operating free-air temperature range†

Supply voltage range, V_{CC}	-0.5 V to 7 V
Input clamp current, I_{IK} ($V_I < 0$ or $V_I > V_{CC}$) (see Note 1)	± 20 mA
Output clamp current, I_{OK} ($V_O < 0$ or $V_O > V_{CC}$) (see Note 1)	± 20 mA
Continuous output current, I_O ($V_O = 0$ to V_{CC})	± 25 mA
Continuous current through V_{CC} or GND	± 50 mA
Package thermal impedance, θ_{JA} (see Note 2): D package	127°C/W
DB package	158°C/W
N package	78°C/W
Storage temperature range, T_{stg}	-65°C to 150°C

† Stresses beyond those listed under "absolute maximum ratings" may cause permanent damage to the device. These are stress ratings only, and functional operation of the device at these or any other conditions beyond those indicated under "recommended operating conditions" is not implied. Exposure to absolute-maximum-rated conditions for extended periods may affect device reliability.

- NOTES: 1. The input and output voltage ratings may be exceeded if the input and output current ratings are observed.
2. The package thermal impedance is calculated in accordance with JESD 51, except for through-hole packages, which use a trace length of zero.

SN54HC393, SN74HC393 DUAL 4-BIT BINARY COUNTERS

SCLS143B – DECEMBER 1982 – REVISED MAY 1997

recommended operating conditions

		SN54HC393			SN74HC393			UNIT
		MIN	NOM	MAX	MIN	NOM	MAX	
V _{CC}	Supply voltage	2	5	6	2	5	6	V
V _{IH}	High-level input voltage	V _{CC} = 2 V	1.5		1.5		V	
		V _{CC} = 4.5 V	3.15		3.15			
		V _{CC} = 6 V	4.2		4.2			
V _{IL}	Low-level input voltage	V _{CC} = 2 V	0	0.5	0	0.5	V	
		V _{CC} = 4.5 V	0	1.35	0	1.35		
		V _{CC} = 6 V	0	1.8	0	1.8		
V _I	Input voltage	0	V _{CC}		0	V _{CC}		V
V _O	Output voltage	0	V _{CC}		0	V _{CC}		V
t _t [†]	Input transition (rise and fall) time	V _{CC} = 2 V	0	1000	0	1000	ns	
		V _{CC} = 4.5 V	0	500	0	500		
		V _{CC} = 6 V	0	400	0	400		
T _A	Operating free-air temperature	-55		125	-40		85	°C

[†] If this device is used in the threshold region (from V_{ILmax} = 0.5 V to V_{IHmin} = 1.5 V), there is a potential to go into the wrong state from induced grounding, causing double clocking. Operating with the inputs at t_t = 1000 ns and V_{CC} = 2 V does not damage the device; however, functionally, the CLK inputs are not ensured while in the shift, count, or toggle operating modes.

electrical characteristics over recommended operating free-air temperature range (unless otherwise noted)

PARAMETER	TEST CONDITIONS	V _{CC}	T _A = 25°C			SN54HC393		SN74HC393		UNIT
			MIN	TYP	MAX	MIN	MAX	MIN	MAX	
V _{OH}	V _I = V _{IH} or V _{IL}	I _{OH} = -20 μA	2 V	1.9	1.998	1.9	1.9	V		
			4.5 V	4.4	4.499	4.4	4.4			
			6 V	5.9	5.999	5.9	5.9			
		I _{OH} = -4 mA	4.5 V	3.98	4.3	3.7	3.84			
			6 V	5.48	5.8	5.2	5.34			
V _{OL}	V _I = V _{IH} or V _{IL}	I _{OL} = 20 μA	2 V	0.002	0.1	0.1	0.1	V		
			4.5 V	0.001	0.1	0.1	0.1			
			6 V	0.001	0.1	0.1	0.1			
		I _{OL} = 4 mA	4.5 V	0.17	0.26	0.4	0.33			
			6 V	0.15	0.26	0.4	0.33			
I _I	V _I = V _{CC} or 0	6 V	±0.1	±100	±1000	±1000	nA			
I _{CC}	V _I = V _{CC} or 0, I _O = 0	6 V	8		160	80	μA			
C _i		2 V to 6 V	3	10	10	10	pF			



SN54HC393, SN74HC393 DUAL 4-BIT BINARY COUNTERS

SCLS143B – DECEMBER 1982 – REVISED MAY 1997

timing requirements over recommended operating free-air temperature range (unless otherwise noted)

		V _{CC}	T _A = 25°C		SN54HC393		SN74HC393		UNIT
			MIN	MAX	MIN	MAX	MIN	MAX	
f _{clock}	Clock frequency	2 V	0	6	0	4.2	0	5	MHz
		4.5 V	0	31	0	21	0	25	
		6 V	0	36	0	25	0	28	
t _w	Pulse duration	CLK high or low	2 V	80		120		100	ns
			4.5 V	16		24		20	
			6 V	14		20		18	
		CLR high	2 V	80		120		100	
			4.5 V	16		24		20	
			6 V	14		20		18	
t _{su}	Setup time, CLR inactive	2 V	25		25		25	ns	
		4.5 V	5		5		5		
		6 V	5		5		5		

switching characteristics over recommended operating free-air temperature range, C_L = 50 pF (unless otherwise noted) (see Figure 1)

PARAMETER	FROM (INPUT)	TO (OUTPUT)	V _{CC}	T _A = 25°C			SN54HC393		SN74HC393		UNIT
				MIN	TYP	MAX	MIN	MAX	MIN	MAX	
f _{max}	CLK	Q _A	2 V	6	10		4.2		5	MHz	
			4.5 V	31	50		21		25		
			6 V	36	60		25		28		
t _{pd}	CLK	Q _A	2 V		50	120		180		150	ns
			4.5 V		15	24		36		30	
			6 V		13	20		31		26	
		Q _B	2 V		72	190		285		240	
			4.5 V		22	38		57		47	
			6 V		18	32		48		40	
		Q _C	2 V		91	240		360		300	
			4.5 V		28	48		72		60	
			6 V		22	41		61		51	
		Q _D	2 V		100	290		430		360	
			4.5 V		32	58		87		72	
			6 V		24	50		74		62	
t _{PHL}	CLR	Any	2 V		45	165		250		205	ns
			4.5 V		17	33		49		41	
			6 V		14	28		42		35	
t _t		Any	2 V		28	75		110		95	ns
			4.5 V		8	15		22		19	
			6 V		6	13		19		16	

operating characteristics, T_A = 25°C

PARAMETER	TEST CONDITIONS	TYP	UNIT
C _{pd} Power dissipation capacitance per counter	No load	40	pF



SN54HC393, SN74HC393 DUAL 4-BIT BINARY COUNTERS

SCLS143B – DECEMBER 1982 – REVISED MAY 1997

PARAMETER MEASUREMENT INFORMATION

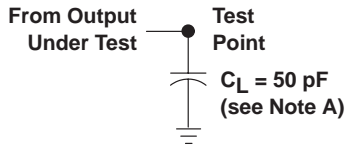

LOAD CIRCUIT

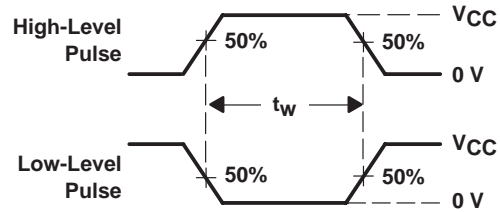

VOLTAGE WAVEFORMS
PULSE DURATIONS

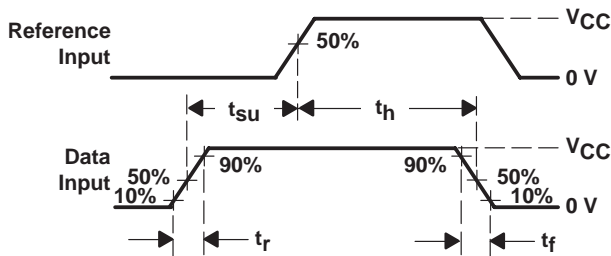

VOLTAGE WAVEFORMS
SETUP AND HOLD AND INPUT RISE AND FALL TIMES

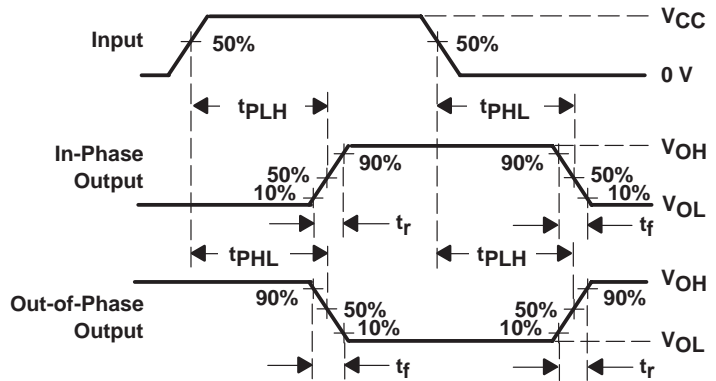

VOLTAGE WAVEFORMS
PROPAGATION DELAY AND OUTPUT TRANSITION TIMES

- NOTES:
- A. C_L includes probe and test-fixture capacitance.
 - B. Phase relationships between waveforms were chosen arbitrarily. All input pulses are supplied by generators having the following characteristics: $PRR \leq 1$ MHz, $Z_O = 50 \Omega$, $t_r = 6$ ns, $t_f = 6$ ns.
 - C. For clock inputs, f_{max} is measured when the input duty cycle is 50%.
 - D. The outputs are measured one at a time with one input transition per measurement.
 - E. t_{PLH} and t_{PHL} are the same as t_{pd} .

Figure 1. Load Circuit and Voltage Waveforms

IMPORTANT NOTICE

Texas Instruments and its subsidiaries (TI) reserve the right to make changes to their products or to discontinue any product or service without notice, and advise customers to obtain the latest version of relevant information to verify, before placing orders, that information being relied on is current and complete. All products are sold subject to the terms and conditions of sale supplied at the time of order acknowledgement, including those pertaining to warranty, patent infringement, and limitation of liability.

TI warrants performance of its semiconductor products to the specifications applicable at the time of sale in accordance with TI's standard warranty. Testing and other quality control techniques are utilized to the extent TI deems necessary to support this warranty. Specific testing of all parameters of each device is not necessarily performed, except those mandated by government requirements.

CERTAIN APPLICATIONS USING SEMICONDUCTOR PRODUCTS MAY INVOLVE POTENTIAL RISKS OF DEATH, PERSONAL INJURY, OR SEVERE PROPERTY OR ENVIRONMENTAL DAMAGE ("CRITICAL APPLICATIONS"). TI SEMICONDUCTOR PRODUCTS ARE NOT DESIGNED, AUTHORIZED, OR WARRANTED TO BE SUITABLE FOR USE IN LIFE-SUPPORT DEVICES OR SYSTEMS OR OTHER CRITICAL APPLICATIONS. INCLUSION OF TI PRODUCTS IN SUCH APPLICATIONS IS UNDERSTOOD TO BE FULLY AT THE CUSTOMER'S RISK.

In order to minimize risks associated with the customer's applications, adequate design and operating safeguards must be provided by the customer to minimize inherent or procedural hazards.

TI assumes no liability for applications assistance or customer product design. TI does not warrant or represent that any license, either express or implied, is granted under any patent right, copyright, mask work right, or other intellectual property right of TI covering or relating to any combination, machine, or process in which such semiconductor products or services might be or are used. TI's publication of information regarding any third party's products or services does not constitute TI's approval, warranty or endorsement thereof.

PRODUCT FOLDER | PRODUCT INFO: [FEATURES](#) | [DESCRIPTION](#) | [DATASHEETS](#) | [PRICING/AVAILABILITY/PKG](#) | [SAMPLES](#)
| [APPLICATION NOTES](#) | [RELATED DOCUMENTS](#)

PRODUCT SUPPORT: [TRAINING](#)

SN74HC393, Dual 4-Bit Binary Counters

DEVICE STATUS: **ACTIVE**

PARAMETER NAME	SN54HC393	SN74HC393
Voltage Nodes (V)	6, 5, 2	6, 5, 2
Vcc range (V)	2.0 to 6.0	2.0 to 6.0
Input Level	CMOS	CMOS
Output Level	CMOS	CMOS
Output Drive (mA)		-4/4
Output	2S	2S
Clear	Async	Async

FEATURES

[▲Back to Top](#)

- Dual 4-Bit Binary Counters With Individual Clocks
- Direct Clear for Each 4-Bit Counter
- Can Significantly Improve System Densities by Reducing Counter Package Count by 50 Percent
- Package Options Include Plastic Small-Outline (D), Shrink Small-Outline (DB), and Ceramic Flat (W) Packages, Ceramic Chip Carriers (FK), and Standard Plastic (N) and Ceramic (J) 300-mil DIPs

DESCRIPTION

[▲Back to Top](#)

The 'HC393 contain eight flip-flops and additional gating to implement two individual 4-bit counters in a single package. The 'HC393 comprise two independent 4-bit binary counters, each having a clear (CLR) and a clock (CLK) input. N-bit binary counters can be implemented with each package, providing the capability of divide by 256. The 'HC393 have parallel outputs from each counter stage so that any submultiple of the input count frequency is available for system timing signals.

The SN54HC393 is characterized for operation over the full military temperature range of -55°C to 125°C. The SN74HC393 is characterized for operation from -40°C to 85°C.

TECHNICAL DOCUMENTS

[▲Back to Top](#)

To view the following documents, [Acrobat Reader 4.0](#) is required.

To download a document to your hard drive, right-click on the link and choose 'Save'.

DATASHEET

[▲Back to Top](#)

Full datasheet in Acrobat PDF: [sn74hc393.pdf](#) (103 KB, Rev.B) (Updated: 05/01/1997)

APPLICATION NOTES

[▲Back to Top](#)

View Application Notes for [Digital Logic](#)

- [CMOS Power Consumption and CPD Calculation \(Rev. B\)](#) (SCAA035B - Updated: 06/01/1997)
- [Designing With Logic \(Rev. C\)](#) (SDYA009C - Updated: 06/01/1997)
- [Evaluation of Nickel/Palladium/Gold-Finished Surface-Mount Integrated Circuits](#) (SZZA026 - Updated: 06/20/2001)
- [HCMOS Design Considerations \(Rev. A\)](#) (SCLA007A - Updated: 09/09/2002)

- [Implications of Slow or Floating CMOS Inputs \(Rev. C\)](#) (SCBA004C - Updated: 02/01/1998)
- [Input and Output Characteristics of Digital Integrated Circuits](#) (SDYA010 - Updated: 10/01/1996)
- [Live Insertion](#) (SDYA012 - Updated: 10/01/1996)
- [SN54/74HCT CMOS Logic Family Applications and Restrictions](#) (SCLA011 - Updated: 05/01/1996)
- [Selecting the Right Texas Instruments Signal Switch \(SZZA030](#) - Updated: 09/07/2001)
- [Using High Speed CMOS and Advanced CMOS in Systems With Multiple Vcc](#) (SCLA008 - Updated: 04/01/1996)

RELATED DOCUMENTS

[▲Back to Top](#)

View Related Documentation for [Digital Logic](#)

- [Logic Reference Guide](#) (SCYB004, 1032 KB - Updated: 10/23/2001)
- [Logic Selection Guide Second Half 2002 \(Rev. R\)](#) (SDYU001R, 4274 KB - Updated: 07/19/2002)
- [Military Semiconductors Selection Guide 2002 \(Rev. B\)](#) (SGYC003B, 1648 KB - Updated: 04/22/2002)

SAMPLES

[▲Back to Top](#)

ORDERABLE DEVICE	PACKAGE INDUSTRY (TI)	PINS	TEMP (°C)	STATUS	PRODUCT CONTENT	SAMPLES
SN74HC393D	SOP (D)	14	-40 TO 85	ACTIVE	View Product Content	Request Samples
SN74HC393DBR	SSOP (DB)	14	-40 TO 85	ACTIVE	View Product Content	Request Samples
SN74HC393N	PDIP (N)	14	-40 TO 85	ACTIVE	View Product Content	Request Samples

PRICING/AVAILABILITY/PKG

[▲Back to Top](#)

DEVICE INFORMATION							TI INVENTORY STATUS AS OF 3:00 PM GMT, 26 Sep 2002			REPORTED DISTRIBUTOR INVENTORY AS OF 3:00 PM GMT, 26 Sep 2002		
ORDERABLE DEVICE	STATUS	PACKAGE TYPE PINS	TEMP (°C)	PRODUCT CONTENT	BUDGETARY PRICING QTY SUS	STD PACK QTY	IN STOCK	IN PROGRESS QTY DATE	LEAD TIME	DISTRIBUTOR COMPANY REGION	IN STOCK	PURCHASE
SN74HC393D	ACTIVE	SOP (D) 14	-40 TO 85	View Contents	1KU 0.29	50	N/A*		6 WKS	Avnet AMERICA	> 1k	BUY NOW
										DigiKey AMERICA	815	BUY NOW
SN74HC393DBR	ACTIVE	SSOP (DB) 14	-40 TO 85	View Contents	1KU 0.29	2000	N/A*	6000 19 Sep	2 WKS			
								1380 25 Sep				
SN74HC393DR	ACTIVE	SOP (D) 14	-40 TO 85	View Contents	1KU 0.29	2500	N/A*	5000 14 Oct	4 WKS			
								413 15 Oct				
SN74HC393N	ACTIVE	PDIP (N) 14	-40 TO 85	View Contents	1KU 0.29	25	7	993 20 Sep	3 WKS	Avnet AMERICA	> 1k	BUY NOW
								100 04 Oct		DigiKey AMERICA	960	BUY NOW
								6085 10 Oct				
SN74HC393N3	OBSOLETE	PDIP (N) 14	-40 TO 85	View Contents	1KU		N/A*		Not Available			
SN74HC393NSR	ACTIVE	SOP (NS) 14	-40 TO 85	View Contents	1KU 0.50	2000	N/A*	2000 07 Oct	3 WKS			

SN74HC393PWR	ACTIVE	TSSOP (PW) 14	-40 TO 85	View Contents	1KU 0.29	2000	N/A*		6 WKS			
--------------	--------	---------------------------------	-----------	-------------------------------	------------	------	----------------------	--	-------	--	--	--

Table Data Updated on: 9/26/2002

[Products](#) | [Applications](#) | [Support](#) | [TI&ME](#)

 **TEXAS INSTRUMENTS** © Copyright 1995-2002 Texas Instruments Incorporated. All rights reserved.

[Trademarks](#) | [Privacy Policy](#) | [Terms of Use](#)