

**Fast CMOS 8-Input Multiplexer**
**Product Features:**

- PI74FCT151/251/2151T is pin compatible with bipolar FAST™ Series at a higher speed and lower power consumption
- 25Ω series resistor on all outputs (FCT2xxx Only)
- TTL input and output levels
- Extremely low static power
- Hysteresis on all inputs
- Industrial operating temperature range: -40°C to +85°C
- Packages available:
  - 16-pin 150-mil wide plastic QSOP (Q16)
  - 16-pin 300-mil wide plastic SOIC (S16)
  - 16-pin 150-mil wide plastic SOIC (W16)

**Product Description:**

Pericom Semiconductor's PI74FCT series of logic circuits are produced in the Company's advanced 0.8 micron CMOS technology, achieving industry leading speed grades.

The PI74FCT151T, PI74FCT251T, and PI74FCT2151T are high-speed 8-input multiplexers. They select one bit from a source of eight under the control of three select inputs. Both assertion and negation outputs are provided.

The PI74FCT151/2151T has a common, active-LOW, Enable input ( $\bar{E}$ ). When  $\bar{E}$  is LOW, data from one of eight inputs is directed to the complementary outputs based on the 3-bit code applied to the Select ( $S_0$ - $S_2$ ) inputs. The PI74FCT151/2151T can be used as a data routing device from one of eight sources.

The PI74FCT251T has a common Active-LOW Output Enable ( $\bar{OE}$ ) input. When  $\bar{OE}$  is LOW, data from one of eight inputs is directed to the complementary outputs. When  $\bar{OE}$  is HIGH, both outputs are switched to a high-impedance state allowing multiplexer expansion by tying several outputs together.

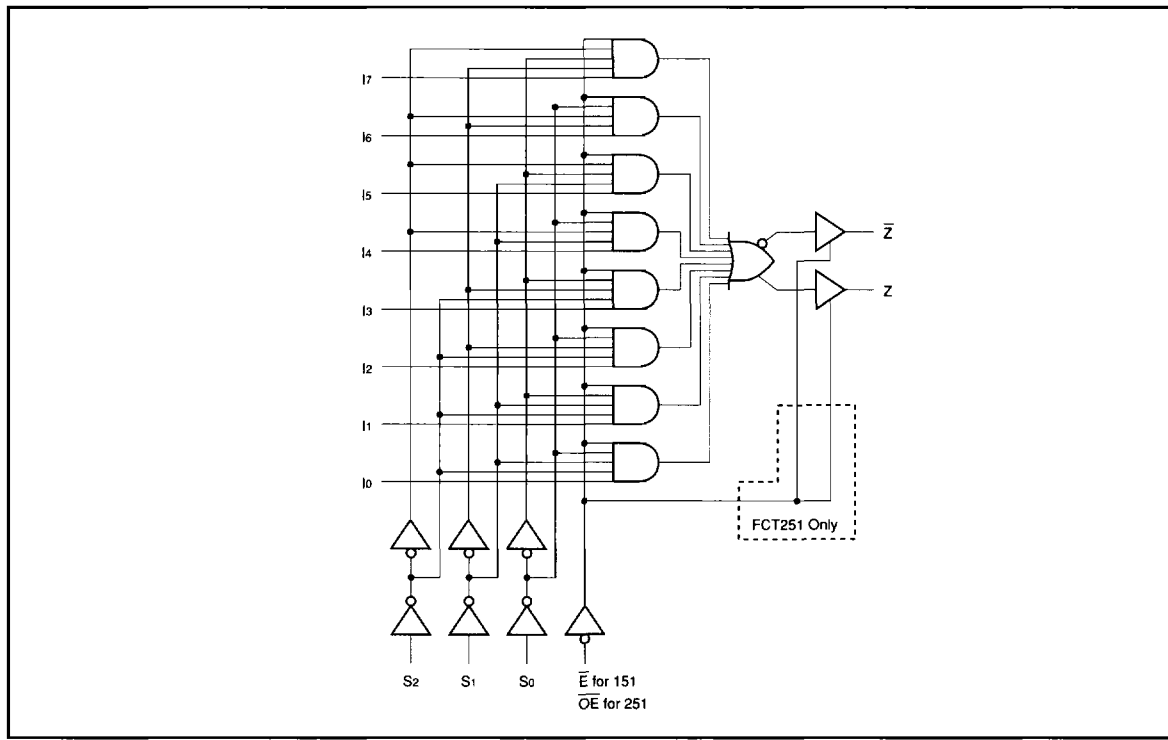
**Logic Block Diagram**

**Product Pin Description**

Pin Name	Description
I0-I7	Data Inputs
S0-S2	Select Inputs
$\bar{E}$	Enable Input (Active LOW) FCT151/2151T
$\bar{OE}$	Output Enable (Active LOW) FCT251T
Z	Data Output
$\bar{Z}$	Inverted Data Output
GND	Ground
Vcc	Power

**Truth Table<sup>(1)</sup>**

Inputs				Outputs	
S2	S1	S0	$\bar{E}/\bar{OE}^{(2)}$	Z	$\bar{Z}$
X	X	X	H	L <sup>(3)</sup>	H <sup>(3)</sup>
X	X	X	H	Z <sup>(4)</sup>	Z <sup>(4)</sup>
L	L	L	L	I0	$\bar{I}0$
L	L	H	L	I1	$\bar{I}1$
L	H	L	L	I2	$\bar{I}2$
L	H	H	L	I3	$\bar{I}3$
H	L	L	L	I4	$\bar{I}4$
H	L	H	L	I5	$\bar{I}5$
H	H	L	L	I6	$\bar{I}6$
H	H	H	L	I7	$\bar{I}7$

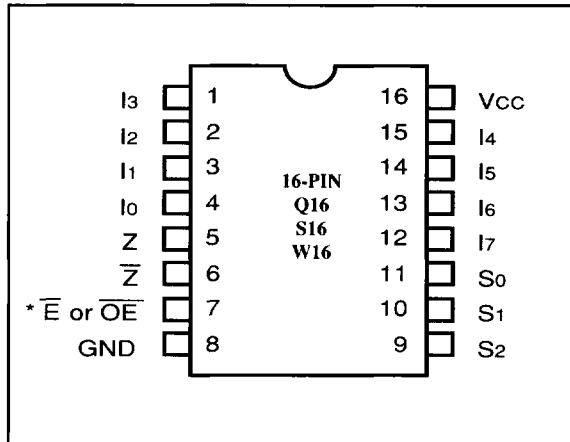
**PI74FCT151/2151T Product Pin Configuration**

**Notes:**

1.  $\bar{E}$  for 151/2151,  $\bar{OE}$  for 251.
2. H = High Voltage Level  
L = Low Voltage Level  
X = Don't Care  
Z = High Impedance
3. 151/2151 ONLY.
4. 251 ONLY.

\*  $\bar{E}$  for 151/2151 only,  $\bar{OE}$  for 251 only

**Maximum Ratings**

(Above which the useful life may be impaired. For user guidelines, not tested.)

Storage Temperature .....	-65°C to +150°C
Ambient Temperature with Power Applied .....	-40°C to +85°C
Supply Voltage to Ground Potential (Inputs & Vcc Only) .....	-0.5V to +7.0V
Supply Voltage to Ground Potential (Outputs & D/O Only) .....	-0.5V to +7.0V
DC Input Voltage .....	-0.5V to +7.0V
DC Output Current .....	120mA
Power Dissipation .....	0.5W

**Note:**

Stresses greater than those listed under MAXIMUM RATINGS may cause permanent damage to the device. This is a stress rating only and functional operation of the device at these or any other conditions above those indicated in the operational sections of this specification is not implied. Exposure to absolute maximum rating conditions for extended periods may affect reliability.

**DC Electrical Characteristics** (Over the Operating Range,  $T_A = -40^\circ\text{C}$  to  $+85^\circ\text{C}$ ,  $V_{CC} = 5V \pm 5\%$ )

Parameters	Description	Test Conditions <sup>(1)</sup>		Min.	Typ <sup>(2)</sup>	Max.	Units
V <sub>OH</sub>	Output HIGH Voltage	$V_{CC} = \text{Min.}, V_{IN} = V_{IH} \text{ or } V_{IL}$	$I_{OH} = -15.0 \text{ mA}$	2.4	3.0		V
V <sub>OL</sub>	Output LOW Current	$V_{CC} = \text{Min.}, V_{IN} = V_{IH} \text{ or } V_{IL}$	$I_{OL} = 48 \text{ mA}$		0.3	0.50	V
V <sub>OL</sub>	Output LOW Current	$V_{CC} = \text{Min.}, V_{IN} = V_{IH} \text{ or } V_{IL}$	$I_{OL} = 12 \text{ mA}$ (25Ω series)		0.3	0.50	V
V <sub>IH</sub>	Input HIGH Voltage	Guaranteed Logic HIGH Level		2.0			V
V <sub>IL</sub>	Input LOW Voltage	Guaranteed Logic LOW Level				0.8	V
I <sub>IH</sub>	Input HIGH Current	$V_{CC} = \text{Max.}$	$V_{IN} = V_{CC}$			1	μA
I <sub>IL</sub>	Input LOW Current	$V_{CC} = \text{Max.}$	$V_{IN} = \text{GND}$			-1	μA
I <sub>OZH</sub>	High Impedance	$V_{CC} = \text{Max.}$	$V_{OUT} = 2.7V$			1	μA
I <sub>OZL</sub>	Output Current	$V_{CC} = \text{Max.}$	$V_{OUT} = 0.5V$			-1	μA
V <sub>IK</sub>	Clamp Diode Voltage	$V_{CC} = \text{Min.}, I_{IN} = -18 \text{ mA}$			-0.7	-1.2	V
I <sub>OS</sub>	Short Circuit Current	$V_{CC} = \text{Max.}^{(3)}, V_{OUT} = \text{GND}$		-60	-120		mA
I <sub>OFF</sub>	Power Down Disable	$V_{CC} = \text{GND}, V_{OUT} = 4.5V$		—	—	100	μA
V <sub>H</sub>	Input Hysteresis				200		mV

**Capacitance** ( $T_A = 25^\circ\text{C}$ ,  $f = 1 \text{ MHz}$ )

Parameters <sup>(4)</sup>	Description	Test Conditions	Typ	Max.	Units
C <sub>IN</sub>	Input Capacitance	$V_{IN} = 0V$	6	10	pF
C <sub>OUT</sub>	Output Capacitance	$V_{OUT} = 0V$	8	12	pF

**Notes:**

1. For Max. or Min. conditions, use appropriate value specified under Electrical Characteristics for the applicable device type.
2. Typical values are at  $V_{CC} = 5.0V$ ,  $+25^\circ\text{C}$  ambient and maximum loading.
3. Not more than one output should be shorted at one time. Duration of the test should not exceed one second.
4. This parameter is determined by device characterization but is not production tested.

**Power Supply Characteristics**

Parameters	Description	Test Conditions <sup>(1)</sup>		Min.	Typ <sup>(2)</sup>	Max.	Units
I <sub>cc</sub>	Quiescent Power Supply Current	V <sub>cc</sub> = Max.	V <sub>IN</sub> = GND or V <sub>cc</sub>		0.1	500	μA
ΔI <sub>cc</sub>	Supply Current per Input @ TTL HIGH	V <sub>cc</sub> = Max.	V <sub>IN</sub> = 3.4V <sup>(3)</sup>		0.5	2.0	mA
I <sub>ccD</sub>	Supply Current per Input per MHz <sup>(4)</sup>	V <sub>cc</sub> = Max., Outputs Open $\bar{E}$ or $\bar{OE}$ = GND One Bit Toggling 50% Duty Cycle	V <sub>IN</sub> = V <sub>cc</sub> V <sub>IN</sub> = GND		0.15	0.25	mA/ MHz
I <sub>c</sub>	Total Power Supply Current <sup>(6)</sup>	V <sub>cc</sub> = Max., Outputs Open f <sub>i</sub> = 10 MHz 50% Duty Cycle $\bar{E}$ or $\bar{OE}$ = GND One Bit Toggling	V <sub>IN</sub> = V <sub>cc</sub> V <sub>IN</sub> = GND		3.2	6.5 <sup>(5)</sup>	mA
			V <sub>IN</sub> = 3.4V V <sub>IN</sub> = GND		3.5	7.5 <sup>(5)</sup>	

**Notes:**

- For conditions shown as Max. or Min., use appropriate value specified under Electrical Characteristics for the applicable device.
- Typical values are at V<sub>cc</sub> = 5.0V, +25°C ambient.
- Per TTL driven input (V<sub>IN</sub> = 3.4V); all other inputs at V<sub>cc</sub> or GND.
- This parameter is not directly testable, but is derived for use in Total Power Supply Calculations.
- Values for these conditions are examples of the I<sub>cc</sub> formula. These limits are guaranteed but not tested.
- I<sub>c</sub> = I<sub>QUIESCENT</sub> + I<sub>INPUTS</sub> + I<sub>DYNAMIC</sub>  
 $I_c = I_{cc} + \Delta I_{cc} D_H N_T + I_{ccD} (f_{CP}/2 + f_i N_i)$   
 I<sub>cc</sub> = Quiescent Current  
 ΔI<sub>cc</sub> = Power Supply Current for a TTL High Input (V<sub>IN</sub> = 3.4V)  
 D<sub>H</sub> = Duty Cycle for TTL Inputs High  
 N<sub>T</sub> = Number of TTL Inputs at D<sub>H</sub>  
 I<sub>ccD</sub> = Dynamic Current Caused by an Input Transition Pair (HLH or LHL)  
 f<sub>CP</sub> = Clock Frequency for Register Devices (Zero for Non-Register Devices)  
 f<sub>i</sub> = Input Frequency  
 N<sub>i</sub> = Number of Inputs at f<sub>i</sub>  
 All currents are in milliamps and all frequencies are in megahertz.

**PI74FCT151/2151T Switching Characteristics over Operating Range**

Parameters	Description	Conditions <sup>(1)</sup>	151T/2151T		151AT/2151AT		151CT/2151CT		Unit
			Com.		Com.		Com.		
			Min	Max	Min	Max	Min	Max	
t <sub>PLH</sub> t <sub>PHL</sub>	Propagation Delay S <sub>n</sub> to $\bar{Z}$	C <sub>L</sub> = 50 pF R <sub>L</sub> = 500Ω	1.5	9.0	1.5	6.6	1.5	5.6	ns
t <sub>PLH</sub> t <sub>PHL</sub>	Propagation Delay S <sub>n</sub> to Z		1.5	10.5	1.5	6.8	1.5	5.8	ns
t <sub>PLH</sub> t <sub>PHL</sub>	Propagation Delay E to $\bar{Z}$		1.5	7.0	1.5	5.6	1.5	4.8	ns
t <sub>PLH</sub> t <sub>PHL</sub>	Propagation Delay $\bar{E}$ to Z		1.5	9.5	1.5	5.8	1.5	5.0	ns
t <sub>PLH</sub> t <sub>PHL</sub>	Propagation Delay I <sub>n</sub> to $\bar{Z}$		1.5	6.5	1.5	5.2	1.5	4.4	ns
t <sub>PLH</sub> t <sub>PHL</sub>	Propagation Delay I <sub>n</sub> to Z		1.5	7.5	1.5	5.5	1.5	4.7	ns

**PI74FCT251T Switching Characteristics over Operating Range**

Parameters	Description	Conditions <sup>(1)</sup>	251T		251AT		251CT		Unit
			Com.		Com.		Com.		
			Min	Max	Min	Max	Min	Max	
t <sub>PLH</sub> t <sub>PHL</sub>	Propagation Delay S <sub>n</sub> to $\bar{Z}$	C <sub>L</sub> = 50 pF R <sub>L</sub> = 500Ω	1.5	9.0	1.5	6.6	1.5	5.6	ns
t <sub>PLH</sub> t <sub>PHL</sub>	Propagation Delay S <sub>n</sub> to Z		1.5	11.0	1.5	6.8	1.5	5.8	ns
t <sub>PLH</sub> t <sub>PHL</sub>	Propagation Delay I <sub>n</sub> to $\bar{Z}$		1.5	7.0	1.5	5.2	1.5	4.4	ns
t <sub>PLH</sub> t <sub>PHL</sub>	Propagation Delay I <sub>n</sub> to Z		1.5	7.0	1.5	5.5	1.5	4.7	ns
t <sub>PZH</sub> t <sub>PZL</sub>	Output Enable Time OE to Z		1.5	9.0	1.5	6.7	1.5	5.7	ns
t <sub>PHZ</sub> t <sub>PLZ</sub>	Output Disable Time <sup>(3)</sup> OE to $\bar{Z}$		1.5	7.5	1.5	6.0	1.5	5.0	ns
t <sub>PZH</sub> t <sub>PZL</sub>	Output Enable Time OE to Z		1.5	9.0	1.5	6.7	1.5	5.7	ns
t <sub>PHZ</sub> t <sub>PLZ</sub>	Output Disable Time <sup>(3)</sup> OE to Z		1.5	7.0	1.5	6.0	1.5	5.0	ns

**Notes:**

1. See test circuit and wave forms.
2. Minimum limits are guaranteed but not tested on Propagation Delays.
3. This parameter is guaranteed but not production tested.