

**Motherboard Clock
Generator****Product Features:**

- Pin-to-Pin compatible with IMISC464 clock generator
- Generates all essential clock signals for Intel microprocessor based motherboard design, including 486-SL Enhanced deep green PC design
- Integrates CPU clock, Keyboard clock, Reference clock
- Integrates a clock buffer to generate four low-skew clock outputs from a single clock input, for motherboard cost reduction
- Power down mode for low power consumption, with selectable DOZE# mode for SL-Enhanced type processor compatibility
- Smooth and glitch-free frequency transition from one CPU clock to another CPU clock—meeting Intel microprocessor spec
- 50% duty cycle
- Uses a low cost 14.318 MHz crystal as reference frequency
- Very low short and long term jitter
- Packages available:
 - 28-pin 300 mil wide plastic PDIP (P28)
 - 28-pin 209 mil wide plastic SSOP (H28)

Product Description:

The PI6C464 motherboard clock generator is a low cost clock generator which generates multiple clocks needed by a motherboard, including a MCLK clock signal, selectable from many popular microprocessor frequencies, plus several peripheral clocks. The MCLK2 clock has the eleven options of 80, 66.6, 60, 50, 40, 33.3, 30, and 25 MHz, giving flexibility to the user. The frequency selection on the MCLK output is determined by the S0-S2 pins and other control pins. A separate pin MCLK1 is provided to offer the one half frequency of MCLK2 clock. In addition, a REF14 output provides a buffered reference frequency of 14.318 MHz.

DOZE# pin gives additional flexibility to the user for Green PC applications. Activating the DOZE# pin smoothly switches the MCLK1 and MCLK2 outputs down to preprogrammed DOZE# frequencies selected by ST1 and ST0 inputs. Deactivating the DOZE# input allows the MCLK1 and MCLK2 outputs to return to full speed.

The PI6C464 includes two independent VCO's, which can be turned off in the tri-state mode, reducing the current consumption.

The PI6C464 offers the low cost solution by replacing the multiple oscillators on the PC motherboards. It can be used with Green PC, laptop, or notebook computers to save power by running the entire system at much slower than normal CPU speed or completely stopping the CPU clock.

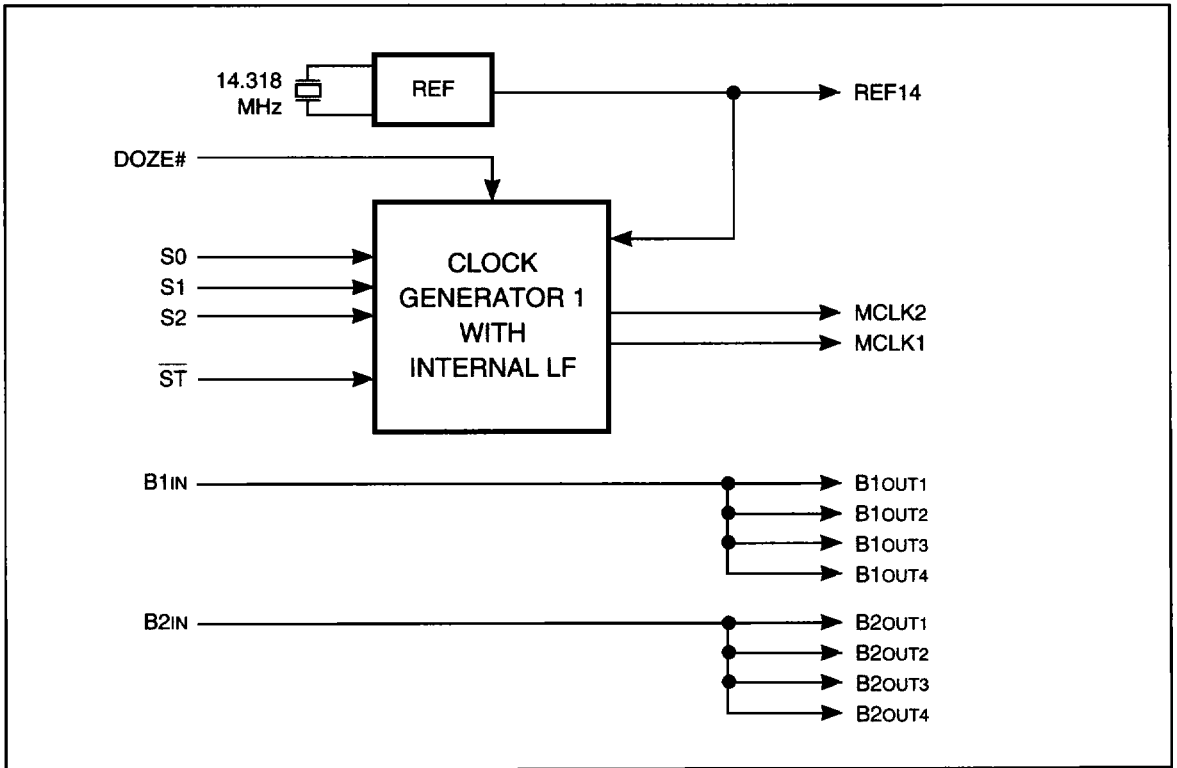
PI6C464 Block Diagram

Product Pin Configuration

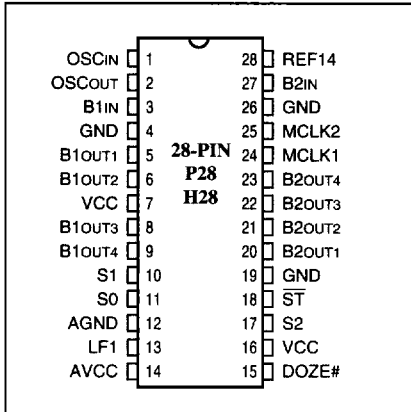

Table 1. Frequency Selection

| Inputs | | | MCLK2 (MHz) | | |
|--------|----|----|-------------|--------|--------|
| | | | DOZE = 0 | | |
| S2 | S1 | S0 | DOZE = 1 | ST = 1 | ST = 0 |
| 0 | 0 | 0 | 66.6 | 33.3 | 16 |
| 0 | 0 | 1 | 80 | 16 | 8 |
| 0 | 1 | 0 | 60 | 33.3 | 16 |
| 0 | 1 | 1 | 30 | 8 | 4 |
| 1 | 0 | 0 | 33.3 | 8 | 4 |
| 1 | 0 | 1 | 40 | 8 | 4 |
| 1 | 1 | 0 | 50 | 8 | 16 |
| 1 | 1 | 1 | 25 | 8 | 4 |

Product Pin Description

| Pin Name | Description |
|--------------------------------|--|
| OSCIN, OSCOUT | These pins form an on-chip reference oscillator when connected to terminals of an external parallel resonant crystal (nominally 14.318 MHz). OSCIN may also serve as input for an externally generated reference signal. |
| S0, S1, S2 | Standard frequency select inputs. These inputs control the high-speed MCLK frequency selection. S2-S0 inputs control the CPU clock frequencies. All these inputs have internal pull-ups. Table 1 shows the output frequency selection conditions. |
| MCLK2 | Master clock output. Programmable output frequencies can be selected using S2-S0 inputs shown in Table 1. |
| DOZE# | DOZE# control pin. When DOZE# is HIGH, the clock chip operates in the standard mode. When this pin goes LOW, output frequencies are switched to the preprogrammed DOZE# frequencies. Switching to DOZE# frequencies occurs smoothly to allow tracking by 486 CPU internal PLL. This pin has an internal pull-up. |
| B1IN, B2IN | On-chip buffer input. These pins have internal pull-ups. |
| B1OUT1-B1OUT4 B2OUT1-B2OUT4 | Buffer output pins of B1IN, B2IN. These buffers are capable of sink or source 12 mA. They can be used to buffer critical clock lines for PCI or VESA applications. |
| MCLK1 | Master clock output divided by 2 (MCLK2/2). |
| REF14 | 14.318 MHz output. Buffered outputs for the on-chip reference oscillator or externally provided reference. |
| LF1 | Connect to an external capacitor. |
| ST | DOZE# frequency select input. This input controls the frequency of MCLK2 when in the DOZE# mode. |
| GND | Circuit ground. |
| AGND | Analog circuit ground. |
| Vcc | Positive power supply. |
| AVcc | Analog positive power supply. |

Maximum Ratings

(Above which the useful life may be impaired. For user guidelines, not tested.)

| | |
|---|-----------------|
| Storage Temperature | -65°C to +150°C |
| Ambient Temperature with Power Applied | 0°C to +70°C |
| Supply Voltage to Ground Potential (Inputs & Vcc Only) | -0.3V to +7.0V |
| Supply Voltage to Ground Potential (Outputs & D/O Only) | -0.3V to +7.0V |
| DC Input Voltage | -0.5V to +7.0V |
| DC Output Current | 120 mA |
| Power Dissipation | 1.0W |

Note:

Stresses greater than those listed under **MAXIMUM RATINGS** may cause permanent damage to the device. This is a stress rating only and functional operation of the device at these or any other conditions above those indicated in the operational sections of this specification is not implied. Exposure to absolute maximum rating conditions for extended periods may affect reliability.

DC Electrical Characteristics (Vcc = 5V ±10%, TA = 0°C to +70°C)

| Parameters | Description | Test Conditions ⁽¹⁾ | Min. | Typ ⁽²⁾ | Max. | Units |
|-----------------|--|---|------|--------------------|----------|-------|
| V _{IH} | Input HIGH Voltage | S2-S0 Inputs, B1 _{IN} , B2 _{IN} Inputs | 2.0 | — | — | V |
| V _{IL} | Input LOW Voltage | S2-S0 Inputs, B1 _{IN} , B2 _{IN} Inputs | — | — | 0.8 | V |
| I _{IH} | Input HIGH Current with Pull-up or Pull-down | S2-S0 Inputs, B1 _{IN} , B2 _{IN} Inputs | — | — | 5 ±50 | µA |
| I _{IL} | Input LOW Current with Pull-up or Pull-down | S2-S0 Inputs, B1 _{IN} , B2 _{IN} Inputs | — | — | 5 ±50 | µA |
| V _{OH} | Output HIGH Voltage | All Outputs, I _{OH} = -12 mA, including B1 _{OUTX} , B2 _{OUTX} | 2.4 | — | — | V |
| V _{OL} | Output LOW Voltage | All Outputs, I _{OL} = 12 mA, including B1 _{OUTX} , B2 _{OUTX} , | — | — | 0.4 | V |
| I _{OS} | Short Circuit Current | V _{CC} = 5.25V ⁽³⁾ , V _{OUT} = GND | 25 | — | — | mA |
| I _{CC} | Static Supply Current | V _{CC} = 5.0V, OSC _{IN} = 0, TS# = 0 | — | — | 10 | µA |
| I _C | Dynamic Supply Current | V _{CC} = 5.0V, MCLK = 50 MHz | — | — | 35 | mA |

NOTES:

1. For conditions shown as Max. or Min., use appropriate values specified under Electrical Characteristics for the appropriate device type.
2. Typical values are at Vcc = 5.0V, +25°C ambient and maximum loading.
3. Not more than one output should be shorted at one time. Duration of test should not exceed one second.

Switching Characteristics (GND = 5V ±10%, T_A = 0°C to +70°C)

| Parameters | Description | Test Conditions | Min. | Typ. | Max. | Units |
|------------------|--|-------------------------------|------|-------|-------|-------|
| tPLH tPHL | Output Rise (0.8V to 2.0V) Fall Time (2.0V to 0.8V) MCLK and REF14 Outputs | 30 pF Load | — | — | 2 | ns |
| dT | Duty Cycle MCLK and REF14 | | — | 50/50 | 45/55 | % |
| tPLH tPHL | Propagation Delay B _{IN} to B _{OUT} | 15 pF Load, Measured at 1.4V | 2.0 | — | 6.5 | ns |
| tSKEW | Buffer Out Skew B _{1OUT1} -B _{1OUT4} | 15 pF Load, Measured at 1.4V | — | — | 0.75 | ns |
| T _{JIS} | Jitter One Sigma MCLK and REF14 | As Compared with Clock Period | — | — | ±2 | % |
| T _{JAB} | Jitter Absolute MCLK and REF14 | As Compared with Clock Period | — | — | ±5 | % |