

1.1 Scope.

This specification covers the detail requirements for a 8-bit resolution D/A converter (DACPORT[®]) complete with output amplifier, full microprocessor interface, precision reference and requiring only +5V.

1.2 Part Number.

The complete part number per Table 1 of this specification is as follows:

Device	Part Number ¹
-1	AD558S(X)/883B
-2	AD558T(X)/883B

NOTE

¹See paragraph 1.2.3 for package identifier.

1.2.3 Case Outline.

See Appendix 1 of General Specification ADI-M-1000: package outline:

(X)	Package	Description
D	D-16	16-Pin DIP (TO-116 Style)
E	E-20A	20-Terminal Leadless Chip Carrier

1.3 Absolute Maximum Ratings. ($T_A = +25^\circ\text{C}$ unless otherwise noted)

V_{CC} to Ground	0 to +18V
Digital Inputs (Pins 1-10)	0 to +7.0V
V_{OUT}	Indefinite Short to Ground Momentary Short to V_{CC}
Power Dissipation	450mW
Storage Temperature Range	-65°C to +150°C
Lead Temperature Range (Soldering 10sec)	300°C

1.5 Thermal Characteristics.

Thermal Resistance θ_{JC}	= 30°C/W
θ_{JA}	= 100°C/W

DACPORT is a registered trademark of Analog Devices, Inc.

AD558—SPECIFICATIONS

Table 1.

Test	Symbol	Device	Design Limit @ +25°C	Sub Group 1	Sub Group 2, 3	Sub Group 4	Test Condition ¹	Units
Relative Accuracy	RA	-1	1/2	1/2	3/4		All Bits with Positive Errors On and All Bits with Negative Errors On	± LSB max
		-2	1/4	1/2	3/8	1/4		
Differential Nonlinearity	DNL	-1, 2	1	1	1		All Major Carriers	± LSB max
Zero Error	V _{OS}	-1	1	1	2	1	All Bits Off	± LSB max
		-2	1/2	1	1	1/2		
Gain Error	A _E	-1	1.5	1.5	2.5	1.5	No Load and 5mA Load	± LSB max
		-2	0.5	1.5	1.0	0.5	All Bits On	
Output Voltage Settling Time		-1, 2	3.0				0 to 10V Range ²	μs max
			1.5				0 to 2.56V Range ²	
Power Supply Rejection Ratio	PSRR	-1, 2	0.03	0.03	0.03		Note 3	%/% max
Power Supply Current	I _{CC}	-1, 2	25	25	25		All Bits On	± mA max
Power Dissipation	PD	-1, 2	125	125	125		V _{CC} = +5V All Bits On	mW max
			375	375	375		V _{CC} = +15V All Bits On	
Digital Input High Voltage	V _{IH}	-1, 2	2.0	2.0	2.0			+ V min
Digital Input Low Voltage	V _{IL}	-1, 2	0.8	0.8	0.8			+ V max
Digital Input High Current	I _{IH}	-1, 2	100	100	100		V _{IH} = 7V	± μA max
Digital Input Low Current	I _{IL}	-1, 2	100	100	100		V _{IL} = 0V	± μA max
Write Pulse Width ⁴	t _{WR}	-1, 2	200		270			ns min
Data Setup Time ⁴	t _{DS}	-1, 2	200		270			ns min
Data Hold Time ⁴	t _{DH}	-1, 2	10		10			ns min

NOTES

¹ V_S = +5V for 0 to 2.56V range, V_S = +15V for 0 to 10V range (unless otherwise noted).

² Settling time is specified for a positive full scale step to ± 1/2LSB.

³ V_{CC} = 4.5V to 5.5V for 0 to 2.56V range, V_{CC} = 11.4V to 16.5V for 0 to 10V range.

⁴ Timing per Figure 1.

3.2.1 Functional Block Diagram and Terminal Assignments.

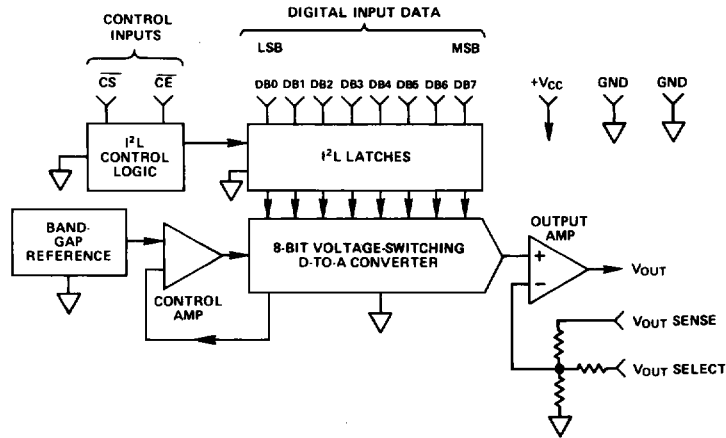

D Package (DIP)

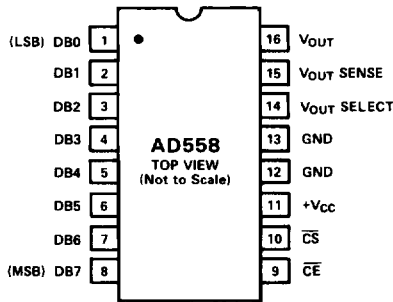

E Package (LCC)

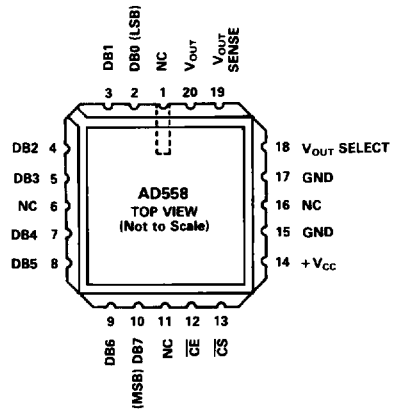

3.2.4 Microcircuit Technology Group.

This microcircuit is covered by technology group (56).

4.2.1 Life Test/Burn-In Circuit.

Steady state life test is per MIL-STD-883 Method 1005. Burn-in is per MIL-STD-883 Method 1015 test condition (B).

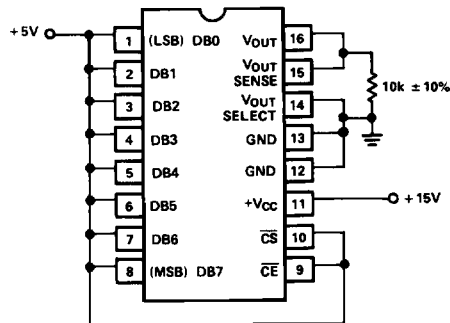

AD558

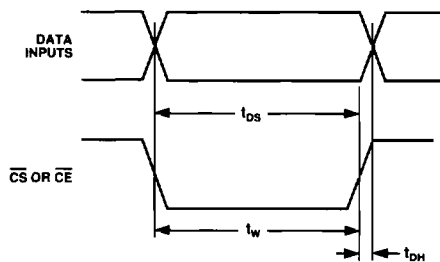

Figure 1. AD558 Timing Diagram

Table 2. AD558 Control Logic Truth Table

Input Data	\overline{CE}	\overline{CS}	DAC Data	Latch Condition
0	0	0	0	"transparent"
1	0	0	1	"transparent"
0	f	0	0	latching
1	f	0	1	latching
0	0	f	0	latching
1	0	f	1	latching
X	1	X	previous data	latched
X	X	1	previous data	latched

Notes: X = Does not matter
 f = Logic Threshold at Positive-Going Transition