

CDC9161 PC MOTHERBOARD CLOCK SYNTHESIZER/DRIVER WITH 3-STATE OUTPUTS

SCAS547B – NOVEMBER 1995 – REVISED JUNE 1996

- P6 Microprocessor Clock Generation With Mixed 2.5-V and 3.3-V Signaling
- Four 2.5-V CPU Clock Outputs With Programmable Frequency (60 MHz and 66 MHz)
- 2.5-V IOAPIC Clock Output
- Eight 3.3-V PCI Clock Outputs
- Two 3.3-V 48-MHz Serial Bus Clocks
- 3.3-V 24-MHz Floppy Controller Clock
- Three 3.3-V 14.318-MHz Reference Clock Outputs
- All Output Clock Frequencies Derived From a Single 14.31818-MHz Crystal Input
- Internal Loop Filters for Phase-Lock Loops (PLLs)
- Power-Down and Test-Mode Support
- Packaged in Plastic 300-mil Shrink Small-Outline Package

**DL PACKAGE
(TOP VIEW)**

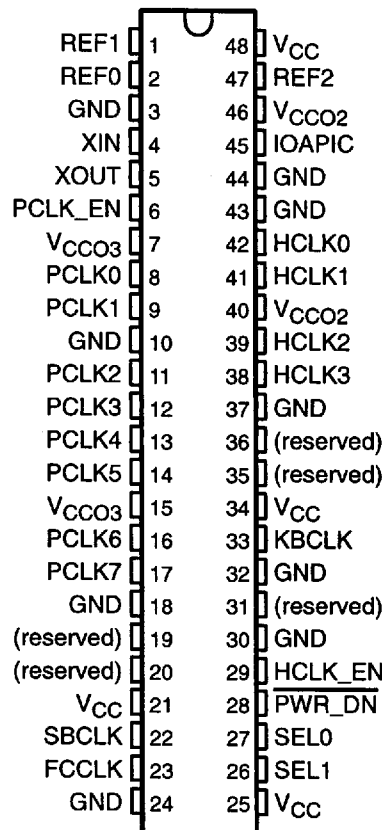

description

The CDC9161 is an integrated clock synthesizer and driver specifically designed for use with microprocessors manufactured by Intel. The CDC9161 generates the necessary clock signals for a high-performance PC motherboard and provides both 2.5-V and 3.3-V signaling to support both processor/chipset clocks and PCI clocks.

The four host clock (HCLKn) outputs are programmable to 60 MHz or 66 MHz via the SEL control inputs. The eight PCI clock (PCLKn) outputs are one-half the HCLK frequency, and are offset 1 ns to 4 ns from the rising edge of the host clock. In addition, the CDC9161 generates a 48-MHz bus clock (SBCLK), 24-MHz floppy controller clock (FCCLK), 12-MHz keyboard controller clock (KBCLK), three copies of the 14.318-MHz reference clock (REFn), and a 2.5-V IOAPIC clock at 14.318 MHz. All output frequencies are generated from a 14.31818-MHz crystal input.

A test clock can be driven over the XIN input in the test mode. The oscillator and PLLs are bypassed when operating in the test mode.

PLLs are used to generate the host clock and serial bus clock frequencies. On-chip loop filters and internal feedback eliminate the need for external components. The PCI clock frequency is derived from the base host clock frequency; FCCLK and KBCLK are derived from the serial bus clock frequency.

The host and PCI clock outputs provide low-skew/low-jitter clock signals for reliable clock operation. All outputs are 3 state and are disabled via the SEL inputs.



Please be aware that an important notice concerning availability, standard warranty, and use in critical applications of Texas Instruments semiconductor products and disclaimers thereto appears at the end of this data sheet.

PRODUCT PREVIEW information concerns products in the formative or design phase of development. Characteristic data and other specifications are design goals. Texas Instruments reserves the right to change or discontinue these products without notice.

**TEXAS
INSTRUMENTS**

POST OFFICE BOX 655303 • DALLAS, TEXAS 75265

Copyright © 1996, Texas Instruments Incorporated

PRODUCT PREVIEW

CDC9161 PC MOTHERBOARD CLOCK SYNTHESIZER/DRIVER WITH 3-STATE OUTPUTS

SCASS47B – NOVEMBER 1995 – REVISED JUNE 1996

description (continued)

Low-power operation also is provided by the HCLK_EN, PCLK_EN, and $\overline{\text{PWR_DN}}$ inputs. HCLK_EN, when low, places all host clocks in the logic low state; all other outputs operate normally. PCLK_EN, when low, places all PCI clocks in the logic low state; all other outputs operate normally. $\overline{\text{PWR_DN}}$, when low, suspends all clock outputs and the internal oscillator and PLLs are disabled to a low-power mode.

Because the CDC9161 is based on PLL circuitry, it requires a stabilization time to achieve phase-lock of the PLL. This stabilization time is required following power up and application of a fixed-frequency, fixed-phase signal at the XIN input, as well as following any changes to the SEL inputs or after the return to normal operation following a low-to-high transition of $\overline{\text{PWR_DN}}$.

FREQUENCY SELECT

SEL1	SEL0	XIN	HCLKN	PCLKN	REFN	IOAPIC	SBCLK	FCCLK	KBCLK
L	L	14.31818 MHz [†]	Hi-Z	Hi-Z	Hi-Z	Hi-Z	Hi-Z	Hi-Z	Hi-Z
L	H	14.31818 MHz	60 MHz	30 MHz	14.318 MHz	14.318 MHz	48 MHz	24 MHz	12 MHz
H	L	14.31818 MHz	66 MHz	33 MHz	14.318 MHz	14.318 MHz	48 MHz	24 MHz	12 MHz
H	H	TCLK [‡]	TCLK/2	TCLK/4	TCLK	TCLK	TCLK/2	TCLK/4	TCLK/8

[†] The allowable reference frequency is minimum = 14.316 MHz, nominal = 14.31818 MHz, and maximum = 14.32 MHz.

[‡] TCLK is a test clock at the XIN input during test mode.

CLOCK ENABLE

$\overline{\text{PWR_DN}}$	HCLK_EN	PCLK_EN	HCLKN	PCLKN	ALL OTHER CLOCKS	VCOS
L	X	X	L	L	L	Static
H	L	L	L	L	Active	Active
H	L	H	L	Active	Active	Active
H	H	L	Active	L	Active	Active
H	H	H	Active	Active	Active	Active

PRODUCT PREVIEW



POST OFFICE BOX 655303 • DALLAS, TEXAS 75265

CDC9161 PC MOTHERBOARD CLOCK SYNTHESIZER/DRIVER WITH 3-STATE OUTPUTS

SCAS547B - NOVEMBER 1995 - REVISED JUNE 1996

functional block diagram

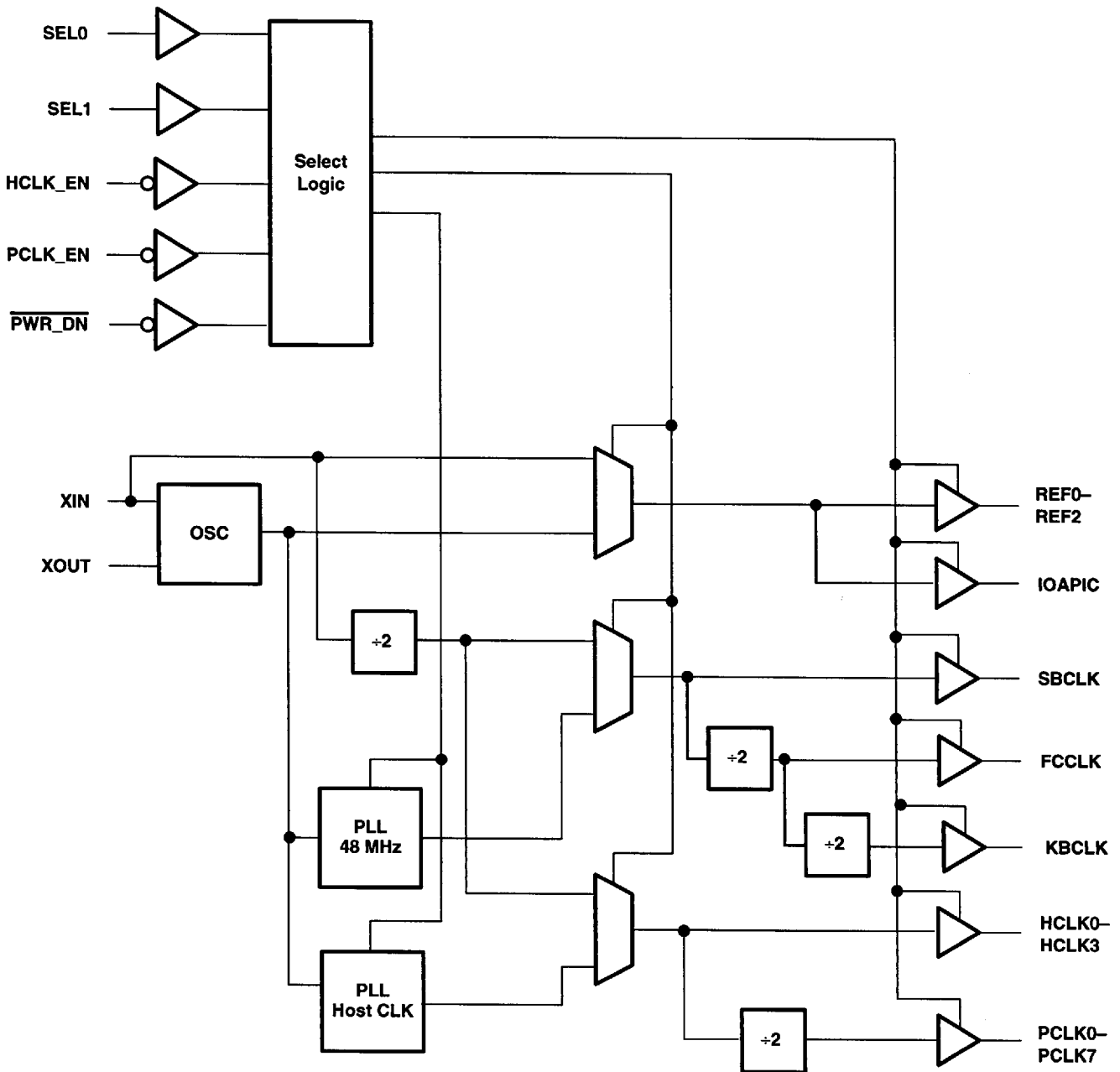

PRODUCT PREVIEW



POST OFFICE BOX 655303 • DALLAS, TEXAS 75265

8961723 0106303 623

CDC9161
PC MOTHERBOARD CLOCK SYNTHESIZER/DRIVER
WITH 3-STATE OUTPUTS

SCAS547B – NOVEMBER 1995 – REVISED JUNE 1996

Terminal Functions

TERMINAL		I/O	DESCRIPTION
NAME	NO.		
FCCLK	23	O	3.3-V floppy controller clock output at 24 MHz
GND	3, 10, 18, 24, 30, 32, 37, 43, 44	GND	Ground
HCLK_EN	29	I	Host (CPU) clock enable
HCLK0–HCLK3	38, 39, 41, 42	O	2.5-V host (CPU) clock outputs programmable to 60 MHz or 66 MHz
IOAPIC	45	O	2.5-V IOAPIC clock output at 14.318 MHz
KBCLK	33	O	3.3-V keyboard controller clock output at 12 MHz
PCLK_EN	6	I	PCI clock enable
PCLK0–PCLK7	8, 9, 11, 12, 13, 14, 16, 17	O	3.3-V PCI clock outputs at one-half HCLK frequency
PWR_DN	28	I	Power-down enable
Reserved	19, 20, 31, 35, 36		Reserved for future use
REF0–REF2	1, 2, 47	O	3.3-V ISA reference clock output at 14.318 MHz
SEL0–SEL1	26, 27	I	Clock frequency select inputs
SBCLK	22	O	3.3-V universal serial bus clock output at 48 MHz
VCC	21, 25, 34, 48	Power	3.3-V core power supply
VCCO3	7, 15	Power	3.3-V output power supply
VCCO2	40, 46	Power	2.5-V output power supply
XIN	4	I	Crystal input
XOUT	5	O	Crystal output

absolute maximum ratings over operating free-air temperature range (unless otherwise noted)†

Supply voltage range, V_{CC}	–0.5 V to 4.6 V
V_{CCO3}	–0.5 V to 4.6 V
V_{CCO2}	–0.5 V to 3.6 V
Input voltage range, V_I (see Note 1)	–0.5 V to 4.6 V
Voltage range applied to any output in the high state or power-off state, V_O	–0.5 V to $V_{CC} + 0.5$ V
Current into any output in the low state, I_O	24 mA
Input clamp current, I_{IK} ($V_I < 0$)	–18 mA
Output clamp current, I_{OK} ($V_O < 0$)	–50 mA
Maximum power dissipation at $T_A = 55^\circ\text{C}$ (in still air) (see Note 2)	1.2 W
Storage temperature range, T_{stg}	–65°C to 150°C

† Stresses beyond those listed under “absolute maximum ratings” may cause permanent damage to the device. These are stress ratings only, and functional operation of the device at these or any other conditions beyond those indicated under “recommended operating conditions” is not implied. Exposure to absolute-maximum-rated conditions for extended periods may affect device reliability.

- NOTES: 1. The input and output negative-voltage ratings may be exceeded if the input and output clamp-current ratings are observed.
 2. The maximum package power dissipation is calculated using a junction temperature of 150°C and a board trace length of 750 mils. For more information, refer to the *Package Thermal Considerations* application note in the *ABT Advanced BiCMOS Technology Data Book*, literature number SCBD002.

PRODUCT PREVIEW



POST OFFICE BOX 655303 • DALLAS, TEXAS 75265

CDC9161
PC MOTHERBOARD CLOCK SYNTHESIZER/DRIVER
WITH 3-STATE OUTPUTS

SCAS547B – NOVEMBER 1995 – REVISED JUNE 1996

recommended operating conditions (see Note 3)

		MIN	MAX	UNIT
V _{CC}	3.3-V core supply voltage	3.135	3.465	V
V _{CCO3}	3.3-V I/O supply voltage	3.135	3.465	V
V _{CCO2}	2.5-V I/O supply voltage	2.375	2.9	V
V _{IH3}	High-level input voltage	2.0	V _{CCO3} +0.3	V
V _{IL3}	Low-level input voltage	-0.3	0.8	V
I _{OH}	High-level output current		-12	mA
I _{OL}	Low-level output current		12	mA
T _A	Operating free-air temperature	0	70	°C

NOTE 3: Unused inputs must be held high or low to prevent them from floating.

electrical characteristics over recommended operating free-air temperature range (unless otherwise noted)

PARAMETER	TEST CONDITIONS		MIN	MAX	UNIT
V _{IK}	V _{CC} = 3.135 V,	I _I = -18 mA		-1.2	V
V _{OH3}	V _{CC} = 3.135 V,	I _{OH} = -1 mA	2.4		V
V _{OL3}	V _{CC} = 3.135 V,	I _{OL} = 1 mA		0.4	V
V _{OH2}	V _{CC} = 2.375 V	I _{OH} = -1 mA	2		V
V _{OL2}	V _{CC} = 2.375 V	I _{OL} = 1 mA		0.4	V
I _I	V _{CC} = 3.465 V,	V _I = V _{CC} or GND	-5	5	μA
I _{OZ}	V _{CC} = 3.465 V,	V _O = 3.135 V or 0			μA
I _{CC}	V _{CC} = 3.465 V, V _I = V _{CC} or GND	I _O = 0,	Outputs high		mA
			Outputs low		
			Outputs disabled		
C _i				5	pF
C _o				6	pF
L _{pin}				7	nH
C _{pd}	V _I = 3.135 V or 0				pF

PRODUCT PREVIEW

timing requirements over recommended ranges of supply voltage and operating free-air temperature (see Figure 4)

		MIN	MAX	UNIT
Stabilization time [†]	After change to SEL0 or SEL1		3	ms
	After PWR_DWN ↑		3	
	After power up		3	

[†] Time required for the integrated PLL circuit to obtain phase lock of its feedback signal to its reference signal. For phase lock to be obtained, a fixed-frequency, fixed-phase reference signal must be present at XIN.



POST OFFICE BOX 655303 • DALLAS, TEXAS 75265

CDC9161
PC MOTHERBOARD CLOCK SYNTHESIZER/DRIVER
WITH 3-STATE OUTPUTS

SCAS547B – NOVEMBER 1995 – REVISED JUNE 1996

switching characteristics (see Figures 1, 2, and 3)

PARAMETER	FROM (INPUT)	TO (OUTPUT)	60 MHz		66 MHz		UNIT
			MIN	MAX	MIN	MAX	
t_c^\dagger		HCLKn	16.7		15		ns
$t_{p(H)}^\dagger$		HCLKn	6.0		5.2		ns
$t_{p(L)}^\dagger$		HCLKn	5.8		5.0		ns
t_r^\ddagger		HCLKn	0.4	1.6	0.4	1.6	ns
t_f^\ddagger		HCLKn	0.4	1.6	0.4	1.6	ps
Jitter †		HCLKn	±250		±250		ps
Duty cycle †		HCLKn	45%	55%	45%	55%	
t_{skew}^\dagger		HCLKn	250		250		ps
t_c^\dagger		PCKLn	33.3		30		ps
$t_{p(H)}^\dagger$		PCKLn	13.3		12		ns
$t_{p(L)}^\dagger$		PCKLn	13.3		12		ps
t_r^\ddagger		PCKLn	0.5	2.0	0.5	2.0	ns
t_f^\ddagger		PCKLn	0.5	2.0	0.5	2.0	ns
Jitter †		PCKLn	±350		±350		ps
Duty cycle †		PCKLn	45%	55%	45%	55%	
t_{skew}^\dagger		PCKLn	500		500		ps
$t_{hpoffset}^\dagger$	HCLKn	PCKLn	1	4	1	4	ns
Clock enable latency	PCLK_EN	PCLKn \uparrow	1	4	1	4	HCLK cycles
	HCLK_EN	HCLKn \uparrow	1	4	1	4	

† Specifications are applicable only after the PLL stabilization time has elapsed.

‡ Rise and fall times are characterized using the load circuits shown in Figure 1.

PRODUCT PREVIEW



POST OFFICE BOX 855303 • DALLAS, TEXAS 75265

PARAMETER MEASUREMENT INFORMATION

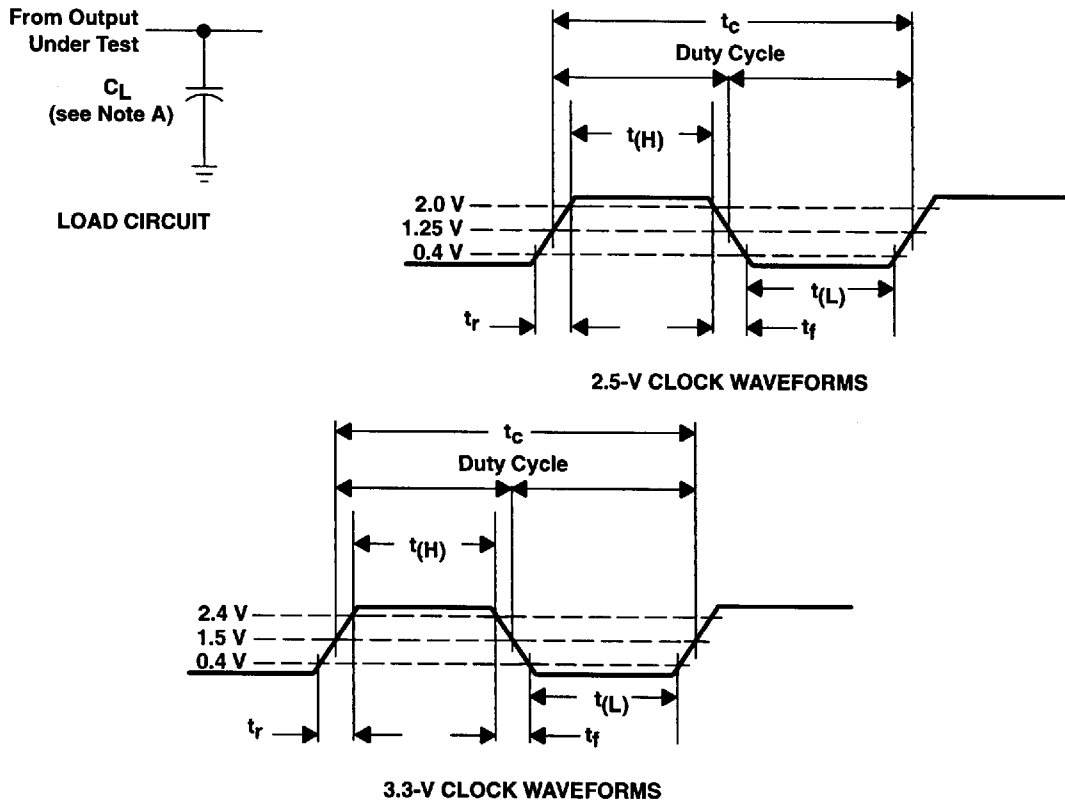

- NOTES: A. C_L includes probe and jig capacitance.
- $C_L = 30\text{pF}$ for PCLK0–PCLK7
 - $C_L = 45\text{pF}$ for REF0
 - $C_L = 20\text{pF}$ for all other outputs
- B. All input pulses are supplied by generators having the following characteristics: $\text{PRR} \leq 10\text{ MHz}$, $Z_O = 50\ \Omega$, $t_r \leq 2.5\text{ ns}$, $t_f \leq 2.5\text{ ns}$.
- C. The outputs are measured one at a time with one transition per measurement.

Figure 1. Load Circuit and Voltage Waveforms

PRODUCT PREVIEW

**CDC9161
PC MOTHERBOARD CLOCK SYNTHESIZER/DRIVER
WITH 3-STATE OUTPUTS**

SCAS547B – NOVEMBER 1995 – REVISED JUNE 1996

PARAMETER MEASUREMENT INFORMATION

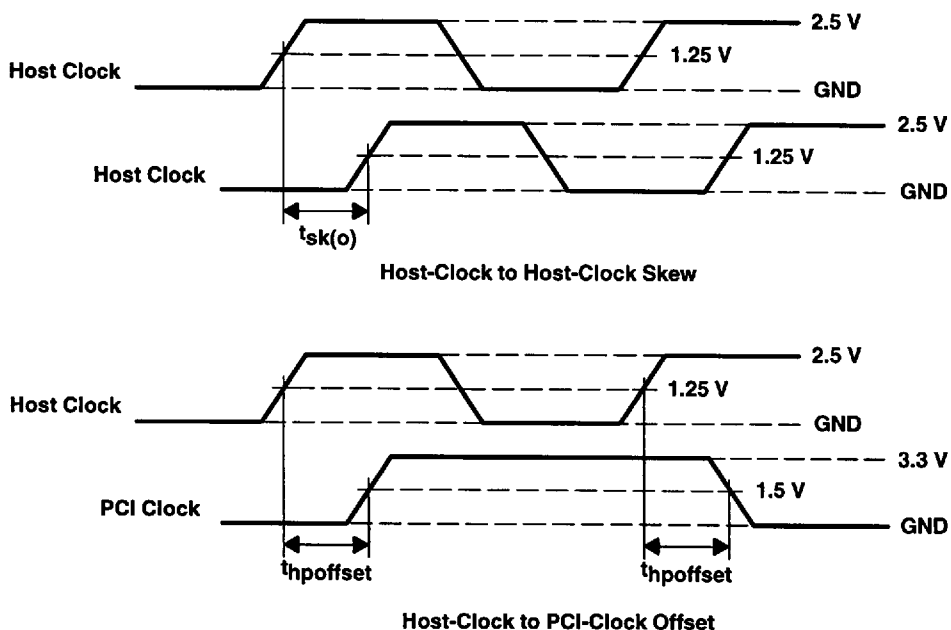

Figure 2. Waveforms for Calculation of $t_{sk(o)}$ and $t_{hpoffset}$

PRODUCT PREVIEW



POST OFFICE BOX 655303 • DALLAS, TEXAS 75265

PARAMETER MEASUREMENT INFORMATION

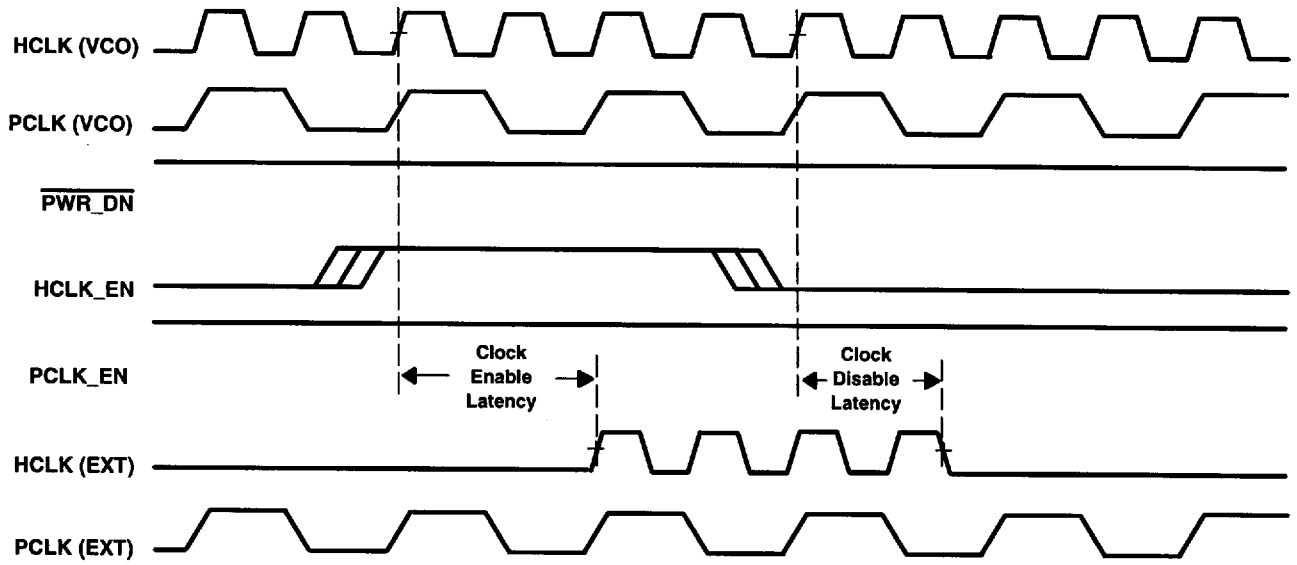

HCLK Enable Timing Diagram

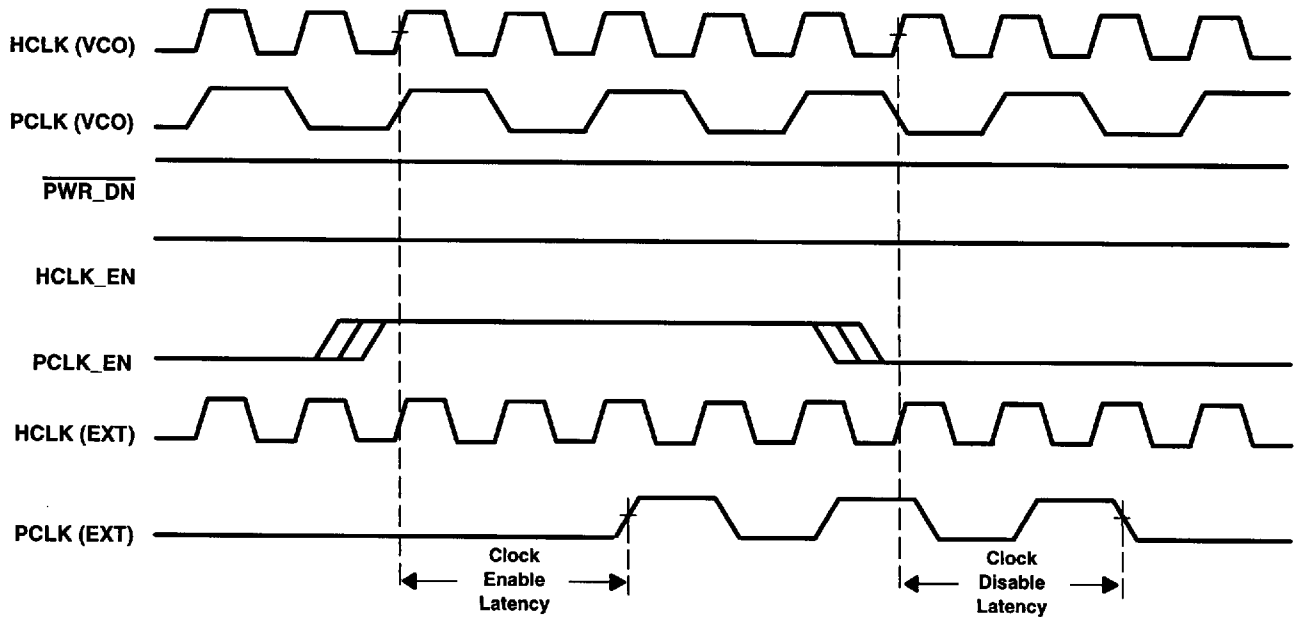

HCLK Enable Timing Diagram

Figure 3. Timing Example

PRODUCT PREVIEW

CDC9161
PC MOTHERBOARD CLOCK SYNTHESIZER/DRIVER
WITH 3-STATE OUTPUTS

SCAS547B – NOVEMBER 1995 – REVISED JUNE 1996

PARAMETER MEASUREMENT INFORMATION

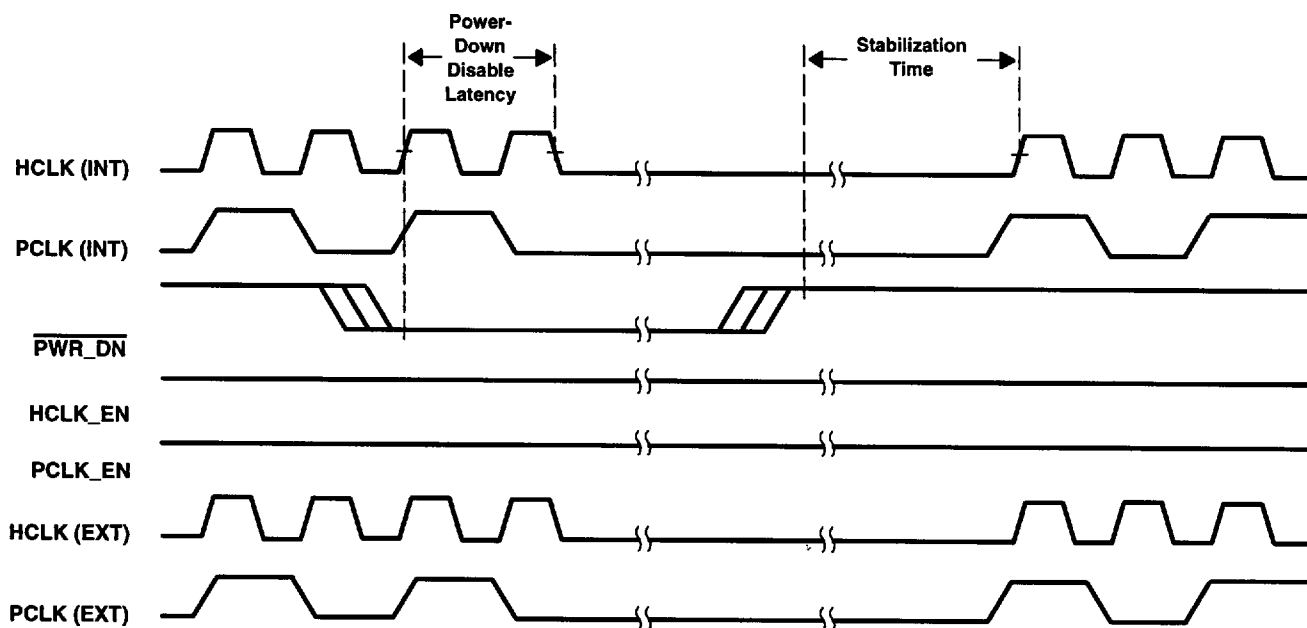

Figure 4. Power-Down Timing

PRODUCT PREVIEW



POST OFFICE BOX 655303 • DALLAS, TEXAS 75265