

SN54LS242, SN54LS243, SN74LS242, SN74LS243 QUADRUPLE BUS TRANSCEIVERS

APRIL 1985—REVISED MARCH 1988

- Two-Way Asynchronous Communication Between Data Buses
- PNP Inputs Reduce D-C Loading
- Hysteresis (Typically 400 mV) at Inputs Improves Noise Margin

SN54LS242, SN54LS243 . . . J OR W PACKAGE
SN74LS242, SN74LS243 . . . D OR N PACKAGE

(TOP VIEW)

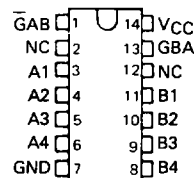

description

These four-data-line transceivers are designed for asynchronous two-way communications between data buses. The SN74LS' can be used to drive terminated lines down to 133 ohms.

The SN54' family is characterized for operation over the full military temperature range of -55°C to 125°C . The SN74' family is characterized for operation from 0°C to 70°C .

FUNCTION TABLE (EACH TRANSCEIVER)

INPUTS		'LS242	'LS243
$\overline{\text{GAB}}$	GBA		
L	L	$\overline{\text{A}}$ to B	A to B
H	H	$\overline{\text{B}}$ to A	B to A
H	L	Isolation	Isolation
L	H	Latch A and B ($\text{A} = \overline{\text{B}}$)	Latch A and B ($\text{A} = \text{B}$)

SN54LS242, SN54LS243 . . . FK PACKAGE

(TOP VIEW)

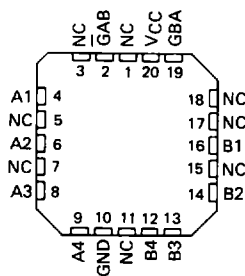

NC—No internal connection

2

TTL Devices

schematics of inputs and outputs

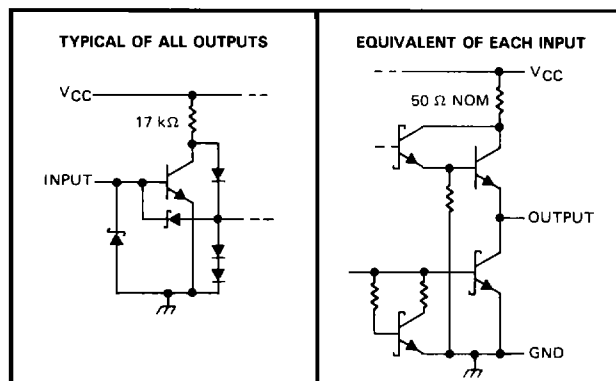

PRODUCTION DATA documents contain information current as of publication date. Products conform to specifications per the terms of Texas Instruments standard warranty. Production processing does not necessarily include testing of all parameters.

TEXAS
INSTRUMENTS

POST OFFICE BOX 655012 • DALLAS TEXAS 75265

2-697

SN54LS242, SN54LS243, SN74LS242, SN74LS243 QUADRUPLE BUS TRANSCEIVERS

logic symbols†

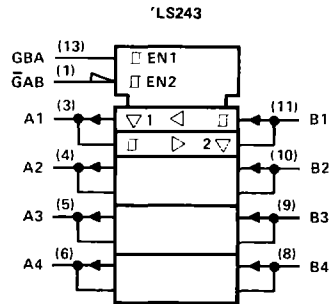
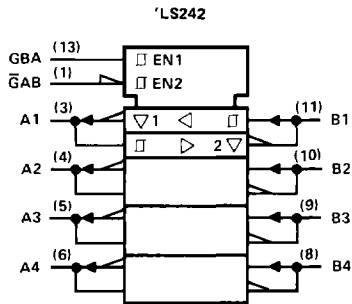

†These symbols are in accordance with ANSI/IEEE Std. 91-1984 and IEC Publication 617-12.

2

TTL Devices

logic diagrams (positive logic)

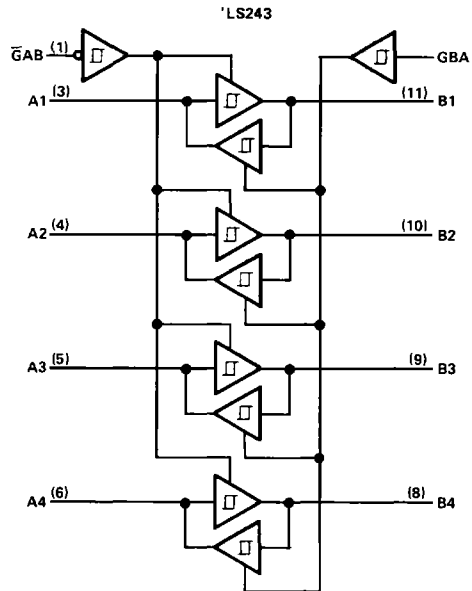
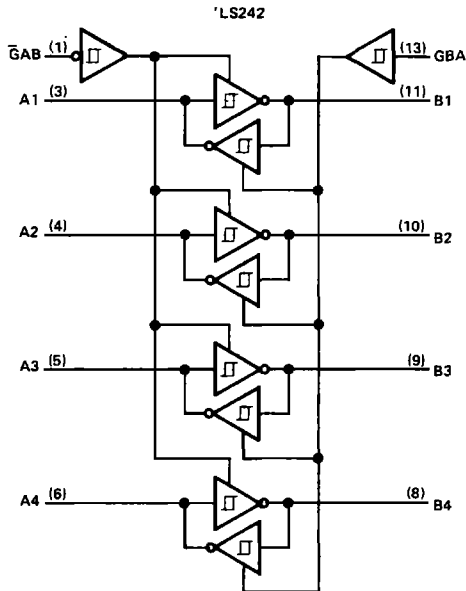

Pin numbers shown are for D, J, N, and W packages.

absolute maximum ratings over operating free-air temperature range (unless otherwise noted)

Supply voltage, V_{CC} (see Note 1)	7 V
Input voltage	7 V
Off-state output voltage	5.5 V
Operating free-air temperature range: SN54LS'	-55°C to 125°C
SN74LS'	0°C to 70°C
Storage temperature range	-65°C to 150°C

NOTE 1. Voltage values are with respect to network ground terminal

SN54LS242, SN54LS243, SN74LS242, SN74LS243 QUADRUPLE BUS TRANSCEIVERS

recommended operating conditions

		SN54LS'			SN74LS'			UNIT
		MIN	NOM	MAX	MIN	NOM	MAX	
V _{CC}	Supply voltage, (see Note 1)	4.5	5	5.5	4.75	5	5.25	V
V _{IH}	High-level input voltage	2			2			V
V _{IL}	Low-level input voltage	0.7			0.8			V
I _{OH}	High-level output current	-12			-15			mA
I _{OL}	Low-level output current	12			24			mA
T _A	Operating free-air temperature	-55			125			°C

electrical characteristics over recommended operating free-air temperature range (unless otherwise noted)

PARAMETER	TEST CONDITIONS†	SN54LS'			SN74LS'			UNIT		
		MIN	TYP‡	MAX	MIN	TYP‡	MAX			
V _{IK}	A or B	V _{CC} = MIN, I _I = -18 mA			-1.5			V		
Hysteresis (V _{T+} - V _{T-})		V _{CC} = MIN			0.2	0.4	0.2	0.4	V	
V _{OH}		V _{CC} = MIN, V _{IH} = 2 V, V _{IL} = MAX, I _{OH} = -3 mA			2.4	3.1	2.4	3.1	V	
		V _{CC} = MIN, V _{IH} = 2 V, V _{IL} = 0.5 V, I _{OH} = MAX			2					
V _{OL}		V _{CC} = MIN, V _{IH} = 2 V, V _{IL} = MAX			0.25		0.4		V	
		I _{OL} = 12 mA					0.25			
		I _{OL} = 24 mA					0.35			
IOZH		V _{CC} = MAX, V _{IH} = 2 V, V _O = 2.7 V			40			μA		
IOZL		V _{IL} = MAX, V _O = 0.4 V			-200			μA		
I _I	A or B	V _{CC} = MAX, V _I = 5.5 V			0.1			mA		
	$\overline{\text{GAB}}$ or GBA	V _{CC} = MAX, V _I = 7 V			0.1					
I _{IH}		V _{CC} = MAX, V _I = 2.7 V			20			μA		
I _{IL}	A inputs	V _{CC} = MAX, V _I = 0.4 V, GAB and GBA at 0 V			-0.2			mA		
	B inputs	V _{CC} = MAX, V _I = 0.4 V, GAB and GBA at 4.5 V			-0.2					
	$\overline{\text{GAB}}$ or GBA	V _{CC} = MAX, V _I = 0.4 V			-0.2					
IOS§		V _{CC} = MAX			-40	-225	-40	-225	mA	
I _{CC}	Outputs high				'LS242, 'LS243		22		38	mA
	Outputs low	V _{CC} = MAX, Outputs open,			'LS242, 'LS243		29		50	
	All outputs disabled	See Note 2			'LS242		29		50	
					'LS243		32		54	

† For conditions shown as MIN or MAX, use the appropriate value specified under recommended operating conditions.

‡ All typical values are at V_{CC} = 5 V, T_A = 25°C.

§ Not more than one output should be shorted at a time, and duration of the short-circuit should not exceed one second.

NOTE 2 I_{CC} is measured with transceivers enabled in one direction only, or with all transceivers disabled

switching characteristics, V_{CC} = 5 V, T_A = 25°C

PARAMETER	TEST CONDITIONS	'LS242			'LS243			UNIT
		MIN	TYP	MAX	MIN	TYP	MAX	
t _{PLH}	R _L = 667 Ω, C _L = 45 pF, See Note 3	9			12			ns
t _{PHL}		12			12			ns
t _{PZL}		20			20			ns
t _{PZH}	R _L = 667 Ω, C _L = 5 pF, See Note 3	15			15			ns
t _{PLZ}		10			10			ns
t _{PHZ}		15			15			ns

NOTE 3: Load circuits and voltage waveforms are shown in Section 1.

2

TTL Devices