

CHOPPER-STABILIZED OPERATIONAL AMPLIFIER

FEATURES

- Low Input Offset Voltage0.7 μV
- Low Input Offset Voltage Drift0.05 $\mu\text{V}/^\circ\text{C}$ Max
- Low Input Bias Current10 pA Max
- High Impedance Differential CMOS Inputs $10^{12}\Omega$
- High Open-Loop Voltage Gain120 dB Min
- Low Input Noise Voltage2.0 $\mu\text{Vp-p}$
- High Slew Rate2.5 V/ μs
- Low-Power Operation20 mW
- Output Clamp Speeds Recovery Time
- Compensated Internally for Stable Unity Gain Operation
- Direct Replacement for ICL7650
- Available in 8-Pin Dip

GENERAL DESCRIPTION

The TC7650 CMOS chopper-stabilized operational amplifier practically removes offset voltage error terms from system error calculations. The 5 μV maximum V_{OS}

specification, for example, represents a 15 times improvement over the industry-standard OP07E. The 50 nV/ $^\circ\text{C}$ offset drift specification is over 25 times lower than the OP07E. The increased performance eliminates V_{OS} trim procedures, periodic potentiometer adjustment and the reliability problems caused by damaged trimmers.

The TC7650 performance advantages are achieved without the additional manufacturing complexity and cost incurred with laser or "zener zap" V_{OS} trim techniques. The TC7650 is one of the lowest cost precision-operational amplifiers available.

The TC7650 nulling scheme corrects both DC V_{OS} errors and V_{OS} drift errors with temperature. A nulling amplifier alternately corrects its own V_{OS} errors and the main amplifier V_{OS} error. Offset nulling voltages are stored on two user-supplied external capacitors. The capacitors connect to the internal amplifier V_{OS} null points. The main amplifier input signal is never switched. Switching spikes are not present at the TC7650 output. The null scheme keeps V_{OS} errors low throughout the operating temperature range. Laser and "zener zap" trimming can correct for V_{OS} at only one temperature.

8

FUNCTIONAL DIAGRAM

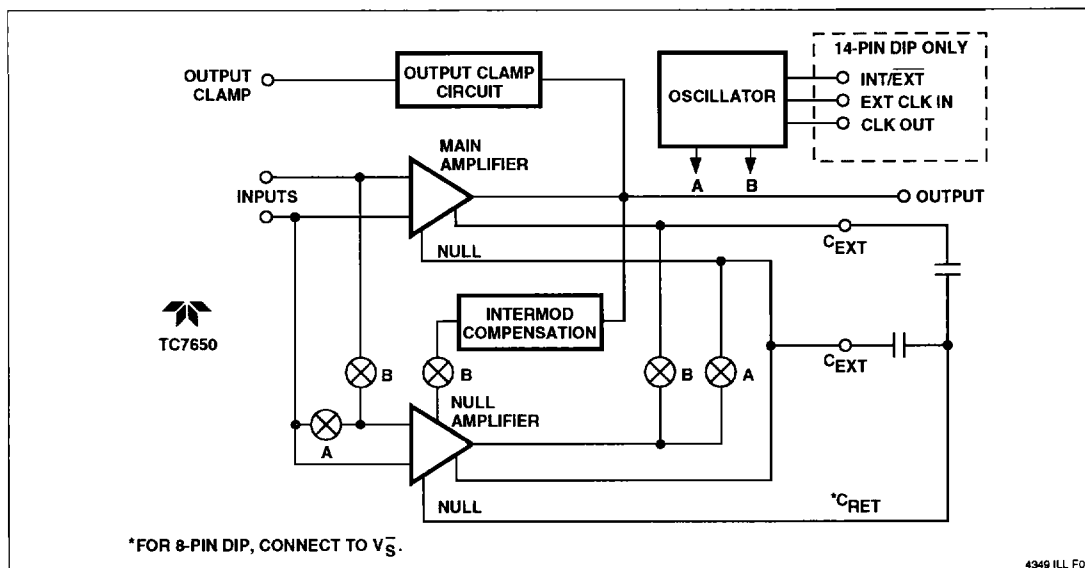

CHOPPER-STABILIZED OPERATIONAL AMPLIFIER

TC7650

The nulling circuit oscillator and control circuits are integrated on-chip. Only two external V_{OS} error storage capacitors are required. The TC7650 operates as a conventional operational amplifier with improved input specifications. The low V_{OS} and V_{OS} drift errors make the TC7650 ideal for thermocouple, thermistor, and strain-gauge applications. Low DC errors and high open-loop gain make the TC7650 an excellent preamplifier for precision analog-to-digital converters, such as the TC7135 and TC800.

The 14-pin dual-in-line package (DIP) has an external oscillator input to drive the nulling circuitry for optimum noise performance. Both the 8- and 14-pin DIPs have an output voltage clamp circuit to minimize overload recovery time.

ORDERING INFORMATION

Part No.	Package	Temperature Range	Max V_{OS}
TC7650CPA	8-Pin Plastic DIP	0°C to +70°C	5 μ V
TC7650IJA	8-Pin CerDIP	-25°C to +85°C	5 μ V
TC7650CPD	14-Pin Plastic DIP	0°C to +70°C	5 μ V
TC7650IJD	14-Pin CerDIP	-25°C to +85°C	5 μ V

PIN CONFIGURATIONS

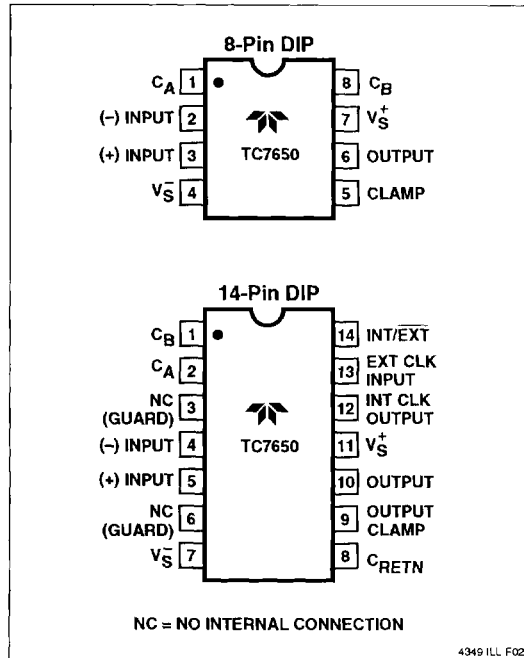

ABSOLUTE MAXIMUM RATINGS

Total Supply Voltage (V_S^+ to V_S^-)	18V
Input Voltage	($V_S^+ + 0.3V$) to ($V_S^- - 0.3V$)
Storage Temperature Range	-65°C to +150°C
Lead Temperature (Soldering, 10 sec)	300°C
Voltage on Oscillator Control Pins	V_S^+ to V_S^-
Output Short Circuit Duration	Indefinite
Current Into Any Pin	10 mA
While Operating (Note 4)	100 μ A
Operating Temperature Range	
I Device	-25°C to +85°C
C Device	0°C to +70°C
Package Power Dissipation ($T_A = 25^\circ\text{C}$)	
CerDIP	500 mW
Plastic DIP	375 mW

Static-sensitive device. Unused devices must be stored in conductive material. Protect devices from static discharge and static fields. Stresses above those listed under Absolute Maximum Ratings may cause permanent damage to the device. These are stress ratings only and functional operation of the device at these or any other conditions above those indicated in the operational sections of the specifications is not implied. Exposure to Absolute Maximum Rating Conditions for extended periods may affect device reliability.

CHOPPER-STABILIZED OPERATIONAL AMPLIFIER

TC7650

ELECTRICAL CHARACTERISTICS: $V_{S^+} = +5V$, $V_{S^-} = -5V$, $C_A = C_B = 0.1 \mu F$, $T_A = 25^\circ C$

Symbol	Parameter	Test Conditions	Min	Typ	Max	Units
Input						
V_{OS}	Input Offset Voltage	$T_A = +25^\circ C$ Over Operating Temp Range (Note 1)	—	± 0.7 ± 1.0	± 5 —	μV
$\Delta V_{OS}/\Delta T$	Input Offset Voltage Average Temperature Coefficient	Operating Temperature Range (Note 1)	—	0.01	0.05	$\mu V/^\circ C$
	Offset Voltage vs. Time		—	100	—	nV/ month
I_{BIAS}	Input Bias Current	$T_A = +25^\circ C$ $0^\circ C \leq T_A \leq +70^\circ C$ $-25^\circ C \leq T_A \leq +85^\circ C$	—	1.5 35 100	10 150 400	pA pA pA
I_{OS}	Input Offset Current	$T_A = +25^\circ C$	—	0.5	—	pA
e_{NP-P}	Input Noise Voltage	$R_S = 100\Omega$, 0 to 10 Hz	—	2	—	μV_{P-P}
I_N	Input Noise Current	$f = 10 \text{ Hz}$	—	0.01	—	pA/\sqrt{Hz}
R_{IN}	Input Resistance		—	10^{12}	—	Ω
CMVR	Common-Mode Voltage Range		-5	-5.2 to +2	+1.6	V
CMRR	Common-Mode Rejection Ratio	CMVR = -5V to +1.5V	120	130	—	dB
Output						
A	Large Signal Voltage Gain	$R_L = 10 \text{ k}\Omega$	120	130	—	dB
V_{OUT}	Output Voltage Swing (Note 3)	$R_L = 10 \text{ k}\Omega$ $R_L = 100 \text{ k}\Omega$	± 4.7 —	± 4.85 ± 4.95	— —	V V
	Clamp ON Current (Note 2)	$R_L = 100 \text{ k}\Omega$	25	70	200	μA
	Clamp OFF Current (Note 2)	$-4V < V_{OUT} < +4V$	—	1	—	pA
Dynamic						
B_W	Unity-Gain Bandwidth	Unity Gain (+1)	—	2.0	—	MHz
S_R	Slew Rate	$C_L = 50 \text{ pF}$, $R_L = 10 \text{ k}\Omega$	—	2.5	—	V/ μs
t_R	Rise Time		—	0.2	—	μs
	Overshoot		—	20	—	%
f_{CH}	Internal Chopping Frequency	Pins 12–14 Open (DIP)	120	200	375	Hz
Supply						
V_{S^+} , V_{S^-}	Operating Supply Range		4.5	—	16	V
I_S	Supply Current	No Load	—	2	3.5	mA
PSRR	Power Supply Rejection Ratio	$V_S = \pm 3V$ to $\pm 8V$	120	130	—	dB

- NOTES:**
1. Operating temperature range is $-25^\circ C$ to $+85^\circ C$ for "I" grade and $0^\circ C$ to $+70^\circ C$ for "C" grade.
 2. See "Output Clamp" discussion.
 3. Output clamp not connected. See typical characteristics curves for output swing versus clamp current characteristics.
 4. Limiting input current to $100 \mu A$ is recommended to avoid latch-up problems.

CHOPPER-STABILIZED OPERATIONAL AMPLIFIER

TC7650

Theory of Operation

Figure 1 shows the major elements of the TC7650. There are two amplifiers (the main amplifier and the nulling amplifier), and both have offset-null capability. The main amplifier is connected full-time from the input to the output. The nulling amplifier, under the control of the chopping frequency oscillator and clock circuit, alternately nulls itself and the main amplifier. Two external capacitors provide the required storage of the nulling potentials and the necessary nulling-loop time constants. The nulling arrangement operates over the full common-mode and power-supply ranges, and is also independent of the output level, thus giving exceptionally high CMRR, PSRR, and A_{VOL} .

Careful balancing of the input switches minimizes chopper frequency charge injection at the input terminals, and the feed-forward-type injection into the compensation capacitor that can cause output spikes in this type circuit.

The circuit's offset voltage compensation is easily shown. With the nulling inputs shorted, a voltage almost identical to the nulling amplifier offset voltage is stored on C_A . The effective offset voltage at the null amplifier input is:

$$V_{OSE} = \frac{1}{A_N + 1} V_{OSN} \quad (1)$$

After the nulling amplifier is zeroed, the main amplifier is zeroed; the A switches open and B switches close.

The output voltage equation is:

$$V_O = A_M [V_{OSM} + (V^+ - V^-) + A_N (V^+ - V^-) + A_N V_{OSE}] \quad (2)$$

Substituting (1) \rightarrow (2) and assuming $A_N \gg 1$:

$$V_O = A_M A_N \left[(V^+ - V^-) + \frac{V_{OSM} + V_{OSN}}{A_N} \right] \quad (3)$$

As desired, the device offset voltages are reduced by the high open-loop gain of the nulling amplifier.

Output Stage/Load Driving

The output circuit is a high-impedance stage (approximately $18 \text{ k}\Omega$). With loads less than this, the chopper amplifier behaves in some ways like a transconductance amplifier whose open-loop gain is proportional to load resistance. For example, the open-loop gain will be 17 dB lower with a $1 \text{ k}\Omega$ load than with a $10 \text{ k}\Omega$ load. If the amplifier is used strictly for DC, the lower gain is of little consequence, since the DC gain is typically greater than 120 dB, even with a $1 \text{ k}\Omega$ load. In wideband applications, the best frequency response will be achieved with a load resistor of $10 \text{ k}\Omega$ or higher. This results in a smooth 6 dB/octave response from 0.1 Hz to 2 MHz, with phase shifts of less than 10° in the transition region, where the main amplifier takes over from the null amplifier. The clock frequency sets the transition region.

Intermodulation

Previous chopper-stabilized amplifiers have suffered from intermodulation effects between the chopper frequency and input signals. These arise because the finite AC gain of the amplifier results in a small AC signal at the input. This is seen by the zeroing circuit as an error signal, which is chopped and fed back, thus injecting sum and difference frequencies, and causing disturbances to the gain and phase versus frequency characteristics near the chopping frequency. These effects are substantially reduced in the TC7650 by feeding the nulling circuit with a dynamic current corresponding to the compensation capacitor current in such a way as to cancel that portion of the input signal due to a finite AC gain. The intermodulation and gain/phase disturbances are held to very low values, and can generally be ignored.

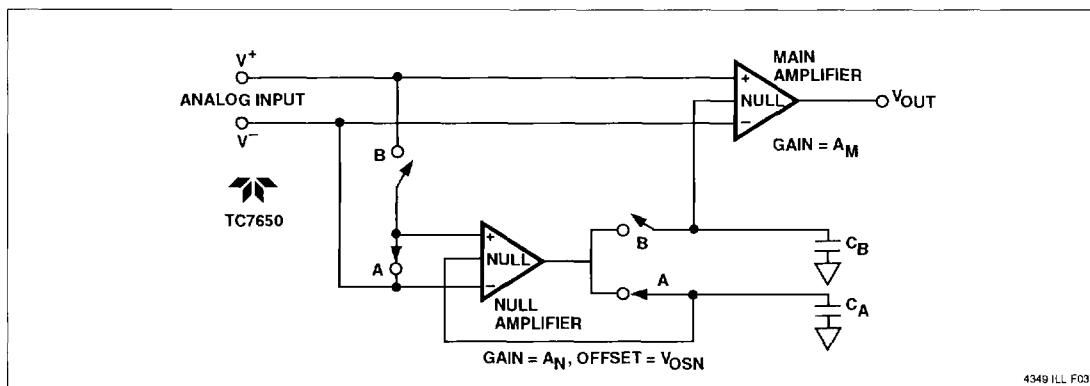

Figure 1 TC7650 Contains a Nulling and Main Amplifier. Offset Correction Voltages Are Stored on Two External Capacitors.

CHOPPER-STABILIZED OPERATIONAL AMPLIFIER

TC7650

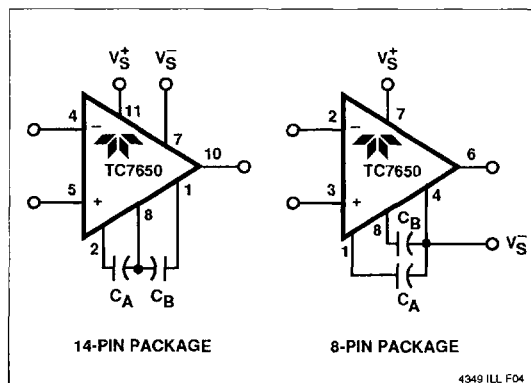

Figure 2 Nulling Capacitor Connection

Nulling Capacitor Connection

The offset voltage correction capacitors are connected to C_A and C_B . The common capacitor connection is made to V_{S^-} (pin 4) on the 8-pin packages and to capacitor return (C_R , pin 8) on the 14-pin packages. The common connection should be made through either a separate PC trace or wire, to avoid voltage drops. The capacitors outside foil, if possible, should be connected to C_R or V_{S^-} .

Clock Operation

The internal oscillator is set for a 200 Hz nominal chopping frequency on both the 8- and 14-pin DIPs. With the 14-pin DIP TC7650, the 200 Hz internal chopping frequency is available at the internal clock output (pin 12). A 400 Hz nominal signal will be present at the external clock input pin (pin 13) with INT/EXT high or open. This is the internal clock signal before a divide-by-two operation.

The 14-pin DIP device can be driven by an external clock. The INT/EXT input (pin 14) has an internal pull-up and may be left open for internal clock operation. If an external clock is used, INT/EXT must be tied to V_{S^-} (pin 7) to disable the internal clock. The external clock signal is applied to the external clock input (pin 13).

The external clock amplitude should swing between V_{S^+} and ground for power supplies up to $\pm 6V$ and between V^+ and $V^+ - 6V$ for higher supply voltages.

At low frequencies the external clock duty cycle is not critical, since an internal divide-by-two gives the desired 50% switching duty cycle. The offset storage correction capacitors are charged only when the external clock input is high. A 50% to 80% external clock positive duty cycle is desired for frequencies above 500 Hz to guarantee transients settle before the internal switches open.

The external clock input can also be used as a strobe input. If a strobe signal is connected at the external clock input so that it is low during the time an overload signal is applied, neither capacitor will be charged. The leakage currents at the capacitors pins are very low. At 25°C a typical TC7650 will drift less than 10 $\mu V/sec$.

Output Clamp

Chopper-stabilized systems can show long recovery times from overloads. If the output is driven to either supply rail, output saturation occurs. The inputs are no longer held at a "virtual ground." The V_{OS} null circuit treats the differential signal as an offset and tries to correct it by charging the external capacitors. The nulling circuit also saturates. Once the input signal returns to normal, the response time is lengthened by the long recovery time of the nulling amplifier and external capacitors.

Through an external clamp connection, the TC7650 eliminates the overload recovery problem by reducing the feedback network gain before the output voltage reaches either supply rail.

8

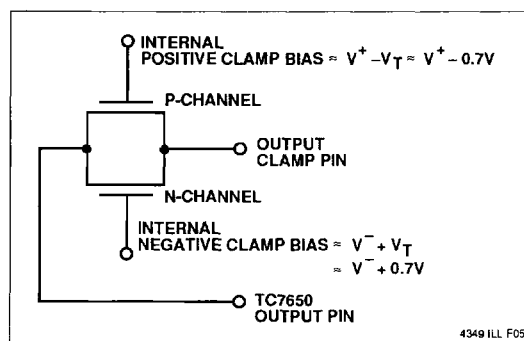

Figure 3 Internal Clamp Circuit

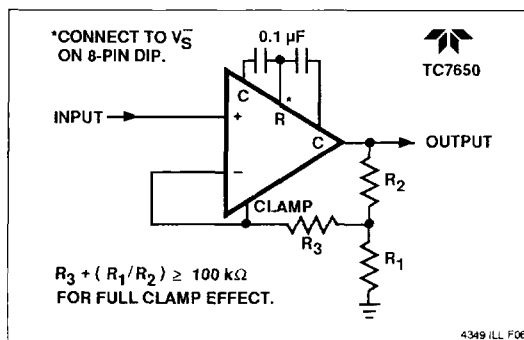

Figure 4 Noninverting Amplifier With Optional Clamp

TC7650

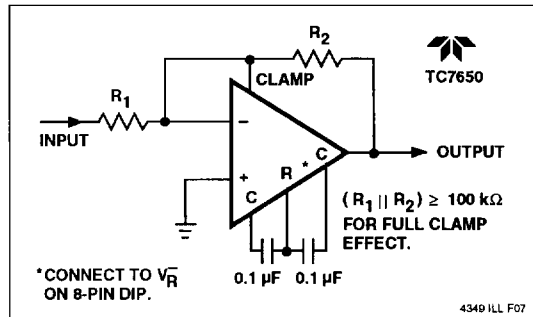

Figure 5 Inverting Amplifier With Optional Clamp

The output clamp circuit is shown in Figure 3, with typical inverting and noninverting circuit connections shown in Figures 4 and 5. Output voltage versus clamp circuit current characteristics are shown in the typical operating curves. For the clamp to be fully effective, the impedance across the clamp output should be greater than 100 k Ω .

Static Protection

All device pins are static-protected. Strong static fields and discharges should be avoided, however, as they can degrade diode junction characteristics and increase input-leakage currents.

Many companies are actively involved in providing services, educational material, and supplies to aid electronic manufacturers in establishing "static safe" work areas where CMOS components are handled. A partial company listing is:

- 3M
Static Control Systems Division
223-25W EM Center
St. Paul, MN 55101
(800) 792-1072
- Semtronics
P.O. Box 592
Martinsville, NJ 08836
(210) 561-9520
- American Converters
1919 South Butlerfield Road
Mundelein, IL 60060
(312) 362-9000
- ACL
1960 East Devon Avenue
Elk Grove Village, IL 60007
(312) 981-9212

Latch-Up Avoidance

Junction-isolated CMOS circuits inherently include a parasitic 4-layer (p-n-p-n) structure which has characteristics similar to an SCR. Under certain circumstances this junction may be triggered into a low-impedance state, resulting in excessive supply current. To avoid this condition, no voltage greater than 0.3V beyond the supply rails should be applied to any pin. In general, the amplifier supplies must be established either at the same time or before any input signals are applied. If this is not possible, the drive circuits must limit input current flow to under 0.1 mA to avoid latch-up.

Thermoelectric Potentials

Precision DC measurements are ultimately limited by thermoelectric potentials developed in thermocouple junctions of dissimilar metals, alloys, silicon, etc. Unless all junctions are at the same temperature, thermoelectric voltages, typically around 0.1 $\mu\text{V}/^\circ\text{C}$, but up to tens of $\mu\text{V}/^\circ\text{C}$ for some materials, will be generated. In order to realize the benefits extremely-low offset voltages provide, it is essential to take special precautions to avoid temperature gradients. All components should be enclosed to eliminate air movement, especially those caused by power-dissipating elements in the system. Low thermoelectric-coefficient connections should be used where possible and power supply voltages and power dissipation should be kept to a minimum. High-impedance loads are preferable, and separation from surrounding heat-dissipating elements is advised.

Pin Compatibility

On the 8-pin mini-DIP TC7650, the external null storage capacitors are connected to pins 1 and 8. On most other operational amplifiers these are left open or are used for offset potentiometer or compensation capacitor connections.

For OP05 and OP07 operational amplifiers, the replacement of the offset null potentiometer between pins 1 and 8 by two capacitors from the pins to V_S^- will convert the OP05/07 pin configurations for TC7650 operation. For LM108 devices, the compensation capacitor is replaced by the external nulling capacitors. The LM101/748/709 pinouts are modified similarly by removing any circuit connections to pin 5. On the TC7650, pin 5 is the output clamp connection. Other operational amplifiers may use this pin as an offset or compensation point.

The minor modifications needed to retrofit a TC7650 into existing sockets operating at reduced power supply voltages make prototyping and circuit verification straightforward.

CHOPPER-STABILIZED OPERATIONAL AMPLIFIER

TC7650

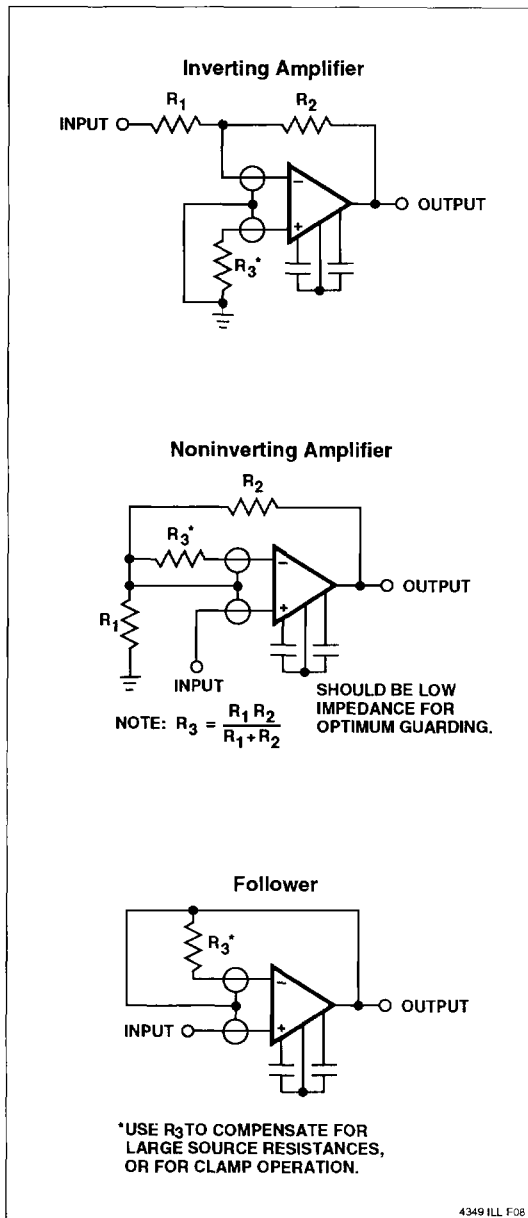

Figure 6 Input Guard Connection

Input Guarding

High impedance, low leakage CMOS inputs allow the TC7650 to make measurements of high-impedance sources. Stray leakage paths can increase input currents and decrease input resistance unless inputs are guarded. A guard is a conductive PC trace surrounding the input terminals. The ring connects to a low-impedance point at the same potential as the inputs. Stray leakages are absorbed by the low-impedance ring. The equal potential between ring and inputs prevents input leakage currents. Typical guard connections are shown in Figure 6.

The 14-pin DIP configuration has been specifically designed to ease input guarding. The pins adjacent to the inputs are unused.

In applications requiring low leakage currents, boards should be cleaned thoroughly and blown dry after soldering. Protective coatings will prevent future board contamination.

Component Selection

The two required capacitors, C_A and C_B , have optimum values, depending on the clock or chopping frequency. For the preset internal clock, the correct value is $0.1 \mu\text{F}$. To maintain the same relationship between the chopping frequency and the nulling time constant, the capacitor values should be scaled in proportion to the external clock, if used. High-quality film-type capacitors (such as Mylar) are preferred; ceramic or other lower-grade capacitors may be suitable in some applications. For fast settling on initial turn-on, low dielectric absorption capacitors (such as polypropylene) should be used. With ceramic capacitors, several seconds may be required to settle to $1 \mu\text{V}$.

8

CHOPPER-STABILIZED OPERATIONAL AMPLIFIER

TC7650

TYPICAL CHARACTERISTIC CURVES

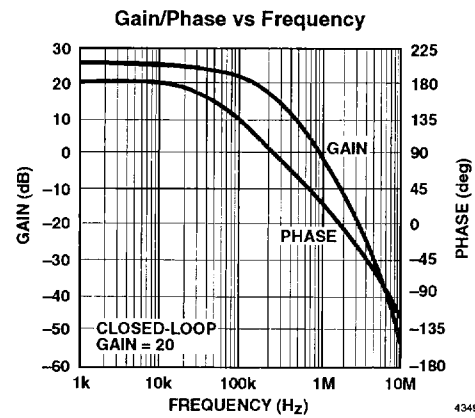
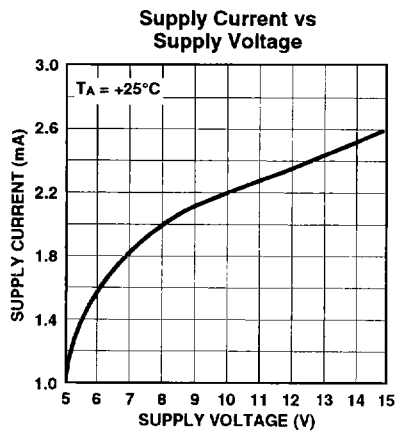
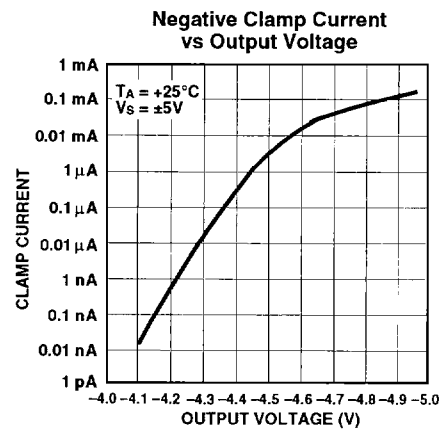
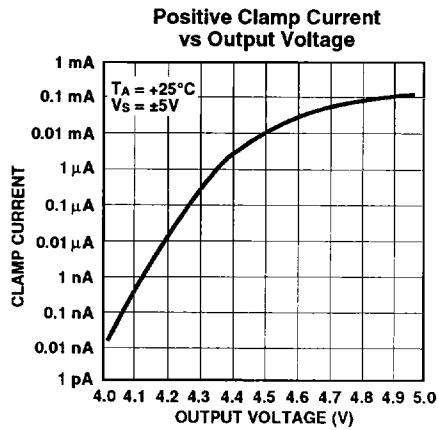

4349 ILL F10