

# PC BOARD CONNECTORS

## 700 SERIES

### ■ FEATURES

The 700 series connector has a superior ejector with a unique flexible latch. Terminals are palladium plated and have an excellent cost performance ratio. The solder dip section is a 0.5 mm (0.020 in.) square and can be used in a  $\phi$ 0.8 mm (0.031 in.) through hole. Special strain relief prevents breakage. Two kinds of keys and bump polarization prevent incorrect insertion. Connectors with 4 mm (0.157 in.) long tails are also available for mounting on multilayer PC boards.

### ■ SPECIFICATIONS

Item	Specification
Operating temperature range	-55°C to +105°C
Current rating	DC 1 A
Voltage rating	AC 250 V
Contact resistance	120 m $\Omega$ max. (DC 6 V, 0.1 A)
Insulation resistance	1000 M $\Omega$ min. (DC 500 V)
Dielectric strength	AC 500 V for 1 minute
Insertion force	3.5 kg max. (10 pins), 21 kg max. (60 pins)
Withdrawal force	0.25 kg min. (10 pins), 2.5 kg min. (60 pins)
Applicable wire	Flat cable: 1.27 mm (0.050 in.) pitch AWG #28 (stranded wires) or AWG #30 (solid wire)
Applicable wire-wrapping wire	AWG #26 to #30 (solid wire)
Applicable PC board (standard)	1.6 mm (0.062 in.) for standard terminal, 3.2 mm (0.125 in.) for long tail



### ■ MATERIALS

Item	Materials	
Insulating material	Polyester (UL94V-0)	
Conductor	Copper alloy	
Plating	Contact	Gold
	Terminal	Palladium

## HEADER FOR DOUBLE STACKED 2ND ROW

### ■ DIMENSIONS

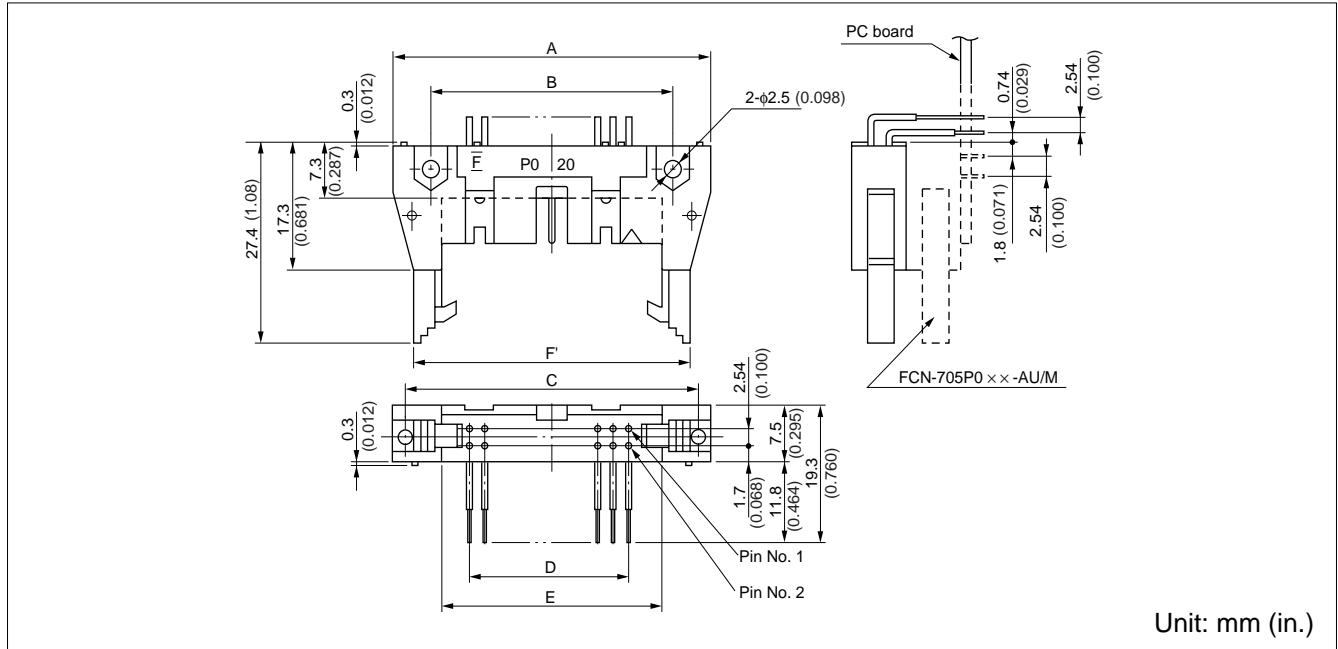

### ■ CONFIGURATION BY THE NUMBER OF PINS

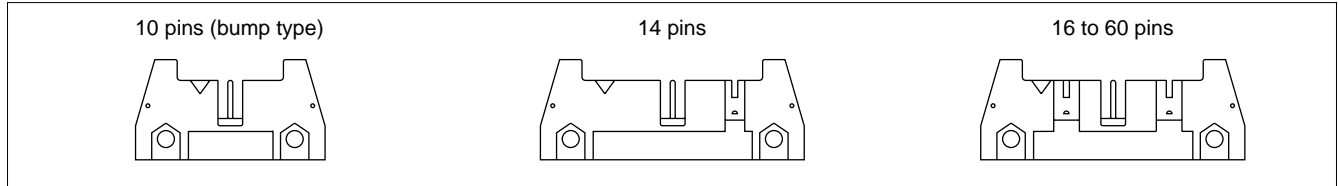

### ■ MOUNTING HOLE LAYOUT

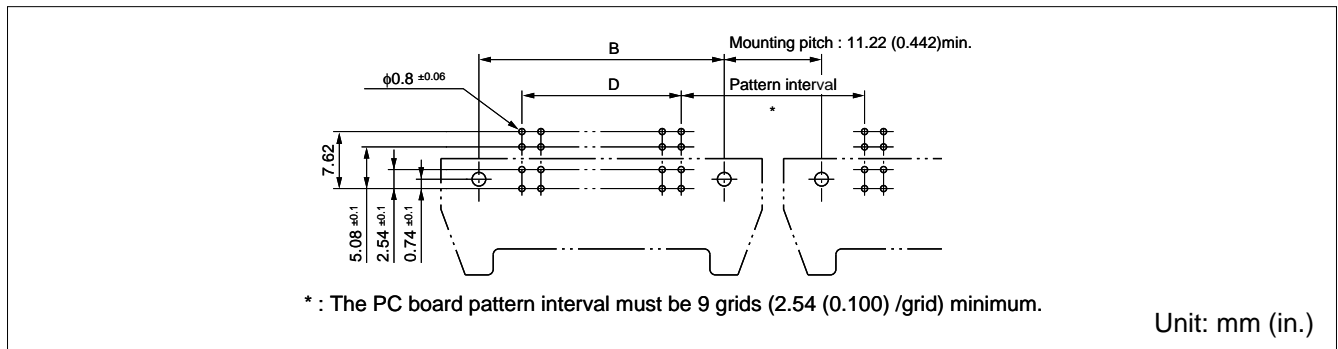

### ■ PART NUMBERS AND DIMENSIONS

Number of contacts	Part number	Dimensions (unit: mm)					
		A	B	C	D	E	F'
10	FCN-709F010-AU/MS	32.0 (1.25)	21.8 (0.858)	27.9 (1.10)	10.16 (0.400)	18.3 (0.720)	26.3 (1.04)
14	FCN-709P014-AU/MS	37.1 (1.46)	26.9 (1.06)	33.0 (1.30)	15.24 (0.600)	23.4 (0.921)	31.4 (1.24)
16	FCN-709P016-AU/MS	39.6 (1.56)	29.4 (1.16)	35.5 (1.40)	17.78 (0.700)	25.9 (1.02)	33.9 (1.33)
20	FCN-709P020-AU/MS	44.7 (1.76)	34.5 (1.36)	40.6 (1.60)	22.86 (0.900)	31.0 (1.22)	39.0 (1.54)
26	FCN-709P026-AU/MS	52.3 (2.06)	42.2 (1.66)	48.3 (1.90)	30.48 (1.20)	38.6 (1.52)	46.6 (1.83)
30	FCN-709P030-AU/MS	57.4 (2.26)	47.2 (1.86)	53.3 (2.10)	35.56 (1.40)	43.7 (1.72)	51.7 (2.04)
34	FCN-709P034-AU/MS	62.5 (2.46)	52.3 (2.06)	58.4 (2.30)	40.64 (1.60)	48.8 (1.92)	56.8 (2.24)
40	FCN-709P040-AU/MS	70.1 (2.76)	59.9 (2.36)	66.0 (2.60)	48.26 (1.90)	56.4 (2.22)	64.4 (2.54)
50	FCN-709P050-AU/MS	82.8 (3.26)	72.6 (2.86)	78.7 (3.10)	60.96 (2.40)	69.0 (2.72)	77.0 (3.03)
60	FCN-709P060-AU/MS	95.5 (3.76)	85.3 (3.36)	91.4 (3.60)	73.66 (2.90)	81.8 (3.22)	89.8 (3.33)

## ACCESSORIES (POLARIZING KEY, LOCK SPRING)

### ■ DIMENSIONS

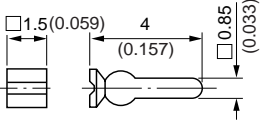
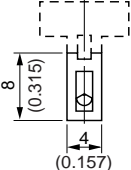
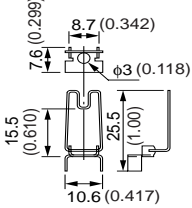
<p>Part number : FCN-700A1</p>  <p>Note : Can be ordered in units of 10.</p> <p>Unit: mm (in.)</p>	<p>Part number : FCN-700A2</p>  <p>Note : Dotted lines indicate the section to be snapped off when used.</p> <p>Unit: mm (in.)</p>	<p>Part number : FCN-700A3 (lock spring)</p>  <p>Unit: mm (in.)</p>
---	---	--

### ■ SPECIFICATION OF POLARITY TO PREVENT INCORRECT INSERTION

• Specify polarity as follows:

• Header (pin type, clip type)

FCN-705P050-AU/M # □ □ △

Basic part number

Common

Pin number with pin polarity

Example

00: No polarity

When the A2 key is not used, only the basic part number is specified without a suffix.

04: Pin 4 is cut or pulled out.

Position of clip type polarity (see the figure on the right)

Note: The standard specification is #04 or the end pin number (if the end pin is 50, the specification is 50).

• Socket (pin type)

FCN-707J050-AU/B # □ □

Basic part number

Common

Pin number with pin polarity

Example

04: FCN-700A1 plugged into pin 4

Note: The specification method is the same for IDC plugs and through hole sockets.

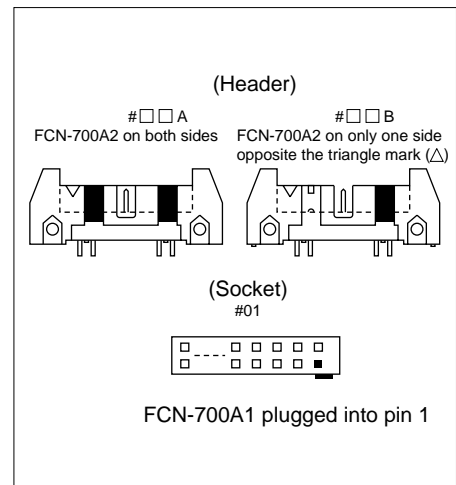

### ■ MOUNTING HOLE LAYOUT

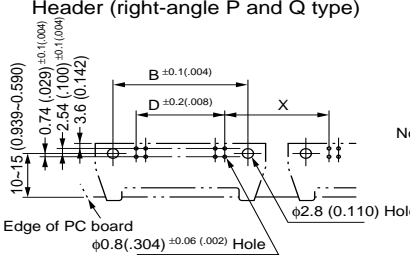
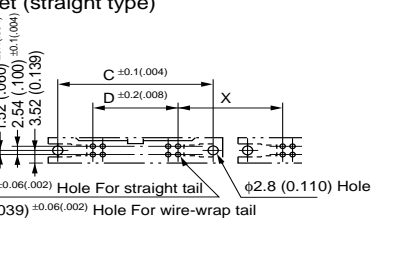
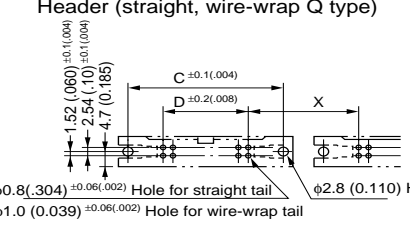
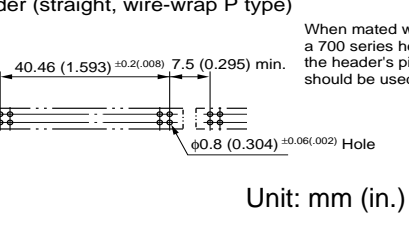
<p>Header (right-angle P and Q type)</p>  <p>Edge of PC board</p> <p>phi 0.8 (0.304) ±0.06 (0.002) Hole</p> <p>phi 2.8 (0.110) Hole</p>	<p>Note : When inserting a 720 series cover, mounting holes should be located less than 9 mm (0.354 in.) from the edge of the PC board.</p> <p>With L latch : 30.48 mm (1.20 in.) min.</p> <p>With M latch, without latch : 22.86 mm (0.900 in.) min. for X</p>	<p>Socket (straight type)</p>  <p>phi 0.8 (0.304) ±0.06(0.002) Hole For straight tail</p> <p>phi 2.8 (0.110) Hole</p> <p>phi 1.0 (0.039) ±0.06(0.002) Hole For wire-wrap tail</p>
<p>Header (straight, wire-wrap Q type)</p>  <p>phi 0.8 (0.304) ±0.06(0.002) Hole for straight tail</p> <p>phi 2.8 (0.110) Hole</p> <p>phi 1.0 (0.039) ±0.06(0.002) Hole for wire-wrap tail</p>	<p>See the table on the preceding page for the dimensions.</p>	<p>Header (straight, wire-wrap P type)</p>  <p>phi 0.8 (0.304) ±0.06(0.002) Hole</p> <p>Unit: mm (in.)</p>

- Notes:
- See the next page for cable termination.
  - See the next page for IDC tools.
  - The last digit (0) of the part number is zero.
  - Use tapping screws JIS B1122, 2.5x6 to mount a straight connector on PC boards.