

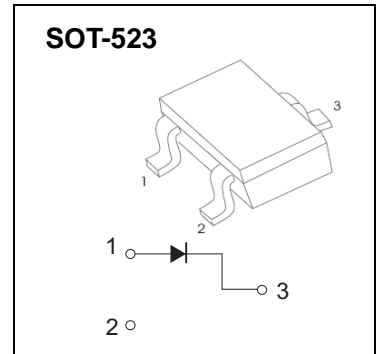

## SOT-523 Plastic-Encapsulate Diodes

**MMBD4148T/BAS16T**

SWITCHING DIODE



### FEATURES

- Fast Switching Speed
- For General Purpose Switching Applications
- High Conductance

Marking: MMBD4148T: KA2,  
BAS16T:A2

### Maximum Ratings @Ta=25°C

Parameter	Symbol	Limit	Unit
Non-Repetitive Peak Reverse Voltage	$V_{RM}$	100	V
Peak Repetitive Peak Reverse Voltage Working Peak Reverse Voltage DC Blocking Voltage	$V_{RRM}$ $V_{RWM}$ $V_R$	75	V
RMS Reverse Voltage	$V_{R(RMS)}$	53	V
Forward Continuous Current	$I_{FM}$	300	mA
Average Rectified Output Current	$I_O$	150	mA
Peak Forward Surge Current @t=1.0μs @ t=1.0s	$I_{FSM}$	2.0 1.0	A
Power Dissipation	$P_d$	200	mW
Thermal Resistance Junction to Ambient	$R_{\theta JA}$	625	K/W
Junction Temperature	$T_j$	150	°C
Storage Temperature	$T_{STG}$	-55~+150	°C

### Electrical Ratings @Ta=25°C

Parameter	Symbol	Min	Typ	Max	Unit	Conditions
Reverse breakdown voltage	$V_{(BR)}$	75			V	$I_R=1\mu A$
Forward voltage	$V_{F1}$			0.715	V	$I_F=1mA$
	$V_{F2}$			0.855	V	$I_F=10mA$
	$V_{F3}$			1.0	V	$I_F=50mA$
	$V_{F4}$			1.25	V	$I_F=150mA$
Reverse current	$I_{R1}$			1	μA	$V_R=75V$
	$I_{R2}$			25	nA	$V_R=20V$
Capacitance between terminals	$C_T$			2	pF	$V_R=0V, f=1MHz$
Reverse recovery time	$t_{rr}$			4	ns	$I_F=I_R=10mA$ $I_{rr}=0.1I_R, R_L=100\Omega$