



128Kx8 MONOLITHIC SRAM

EVOLUTIONARY PINOUT

32 DIP
32 CSOJ (DE)
32 FLAT PACK (FE)

TOP VIEW

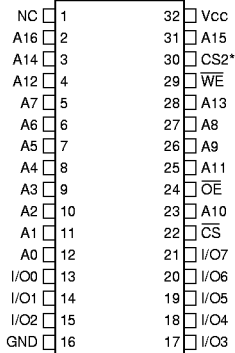

* CS2 for dual chip select devices

PIN DESCRIPTION

A0-16	Address Inputs
I/O0-7	Data Input/Output
CS	Chip Select
OE	Output Enable
WE	Write Enable
Vcc	+5.0V Power
GND	Ground

FEATURES

- Access Times 15, 17, 20, 25, 35, 45, 55ns
- Radiation Tolerant Devices Available
- Evolutionary, Corner Power/Ground Pinout JEDEC Approved
 - 32 pin Ceramic DIP (Package 300)
 - 32 lead Ceramic SOJ (Package 101)
 - 32 lead Ceramic Flat Pack (Package 206)
- MIL-STD-883 Compliant Devices Available
- Commercial, Industrial and Military Temperature Range
- 5 Volt Power Supply
- Low Power CMOS
- 2V Data Retention Devices Available (Low Power Version)
- TTL Compatible Inputs and Outputs

**ABSOLUTE MAXIMUM RATINGS**

Parameter	Symbol	Min	Max	Unit
Operating Temperature	T _A	-55	+125	°C
Storage Temperature	T _{STG}	-65	+150	°C
Signal Voltage Relative to GND	V _G	-0.5	V _{CC} +0.5	V
Junction Temperature	T _J		150	°C
Supply Voltage	V _{CC}	-0.5	7.0	V

RECOMMENDED OPERATING CONDITIONS

Parameter	Symbol	Min	Max	Unit
Supply Voltage	V _{CC}	4.5	5.5	V
Input High Voltage	V _{IH}	2.2	V _{CC} + 0.3	V
Input Low Voltage	V _{IL}	-0.3	+0.8	V
Operating Temp. (Mil.)	T _A	-55	+125	°C

TRUTH TABLE

CS ₂	\overline{CS}	\overline{OE}	\overline{WE}	Mode	Data I/O	Power
X	H	X	X	Standby	High Z	Standby
L	X	X	X	Standby	High Z	Standby
H	L	L	H	Read	Data Out	Active
H	L	X	L	Write	Data In	Active
H	L	H	H	Out Disable	High Z	Active

CAPACITANCE(T_A = +25°C)

Parameter	Symbol	Condition	Max	Unit
Input capacitance	C _{IN}	V _{IN} = 0V, f = 1.0MHz	12	pF
Output capacitance	C _{OUT}	V _{OUT} = 0V, f = 1.0MHz	12	pF

This parameter is guaranteed by design but not tested.

DC CHARACTERISTICS(V_{CC} = 5.0V, GND = 0V, T_A = -55°C to +125°C)

Parameter	Sym	Conditions	-15		-17		-20		-25		Units
			Min	Max	Min	Max	Min	Max	Min	Max	
Input Leakage Current	I _{LI}	V _{CC} = 5.5, V _{IN} = GND to V _{CC}		10		10		10		10	μA
Output Leakage Current	I _{LO}	\overline{CS} = V _{IH} , \overline{OE} = V _{IH} , V _{OUT} = GND to V _{CC}		10		10		10		10	μA
Operating Supply Current	I _{CC}	\overline{CS} = V _{IL} , \overline{OE} = V _{IH} , f = 5MHz, V _{CC} = 5.5		130		130		130		130	mA
Standby Current	I _{SB}	\overline{CS} = V _{IH} , \overline{OE} = V _{IH} , f = 5MHz, V _{CC} = 5.5		20		20		15		15	mA
Output Low Voltage	V _{OL}	I _{OL} = 8mA, V _{CC} = 4.5		0.4		0.4		0.4		0.4	V
Output High Voltage	V _{OH}	I _{OH} = -4.0mA, V _{CC} = 4.5	2.4		2.4		2.4		2.4		V

Parameter	Sym	Conditions	-35		-45		-55		Units
			Min	Max	Min	Max	Min	Max	
Input Leakage Current	I _{LI}	V _{CC} = 5.5, V _{IN} = GND to V _{CC}		10		10		10	μA
Output Leakage Current	I _{LO}	\overline{CS} = V _{IH} , \overline{OE} = V _{IH} , V _{OUT} = GND to V _{CC}		10		10		10	μA
Operating Supply Current	I _{CC}	\overline{CS} = V _{IL} , \overline{OE} = V _{IH} , f = 5MHz, V _{CC} = 5.5		130		130		130	mA
Standby Current	I _{SB}	\overline{CS} = V _{IH} , \overline{OE} = V _{IH} , f = 5MHz, V _{CC} = 5.5		15		15		15	mA
Output Low Voltage	V _{OL}	I _{OL} = 2.1mA, V _{CC} = 4.5		0.4		0.4		0.4	V
Output High Voltage	V _{OH}	I _{OH} = -1.0mA, V _{CC} = 4.5	2.4		2.4		2.4		V

NOTE: DC test conditions: V_{IH} = V_{CC} - 0.3V, V_{IL} = 0.3V



AC CHARACTERISTICS

(V_{CC} = 5.0V, GND = 0V, T_A = -55°C to +125°C)

Parameter Read Cycle	Symbol	-15		-17		-20		-25		-35		-45		-55		Units
		Min	Max	Min	Max	Min	Max	Min	Max	Min	Max	Min	Max	Min	Max	
Read Cycle Time	t _{RC}	15		17		20		25		35		45		55		ns
Address Access Time	t _{AA}		15		17		20		25		35		45		55	ns
Output Hold from Address Change	t _{OH}	0		0		0		0		0		0		0		ns
Chip Select Access Time	t _{ACS}		15		17		20		25		35		45		55	ns
Output Enable to Output Valid	t _{OE}		10		10		12		15		20		25		30	ns
Chip Select to Output in Low Z	t _{CLZ} ¹	3		3		3		3		3		3		3		ns
Output Enable to Output in Low Z	t _{OLZ} ¹	0		0		0		0		0		0		0		ns
Chip Disable to Output in High Z	t _{CHZ} ¹		10		10		10		12		20		20		20	ns
Output Disable to Output in High Z	t _{OHZ} ¹		10		10		10		12		20		20		20	ns
Chip Select to Power-Up Time	t _{PU} ¹	0		0		0		0		0		0		0		ns
Chip Select to Power-Down Time	t _{PD} ¹		15		17		20		25		35		45		55	ns

1. This parameter is guaranteed by design but not tested.

AC CHARACTERISTICS

(V_{CC} = 5.0V, GND = 0V, T_A = -55°C to +125°C)

Parameter Write Cycle	Symbol	-15		-17		-20		-25		-35		-45		-55		Units
		Min	Max	Min	Max	Min	Max	Min	Max	Min	Max	Min	Max	Min	Max	
Write Cycle Time	t _{WC}	15		17		20		25		35		45		55		ns
Chip Select to End of Write	t _{CW}	14		14		15		20		25		30		45		ns
Address Valid to End of Write	t _{AW}	14		15		15		20		25		30		45		ns
Data Valid to End of Write	t _{DW}	10		10		12		15		20		25		25		ns
Write Pulse Width	t _{WP}	14		14		15		20		25		30		45		ns
Address Setup Time	t _{AS}	0		0		0		0		0		0		0		ns
Address Hold Time	t _{AH}	0		0		0		0		0		0		0		ns
Output Active from End of Write	t _{OW} ¹	3		3		3		3		4		4		4		ns
Write Enable to Output in High Z	t _{WHZ} ¹		10		10		12		15		20		25		25	ns
Data Hold Time	t _{DH}	0		0		0		0		0		0		0		ns

1. This parameter is guaranteed by design but not tested.

AC TEST CIRCUIT

AC TEST CONDITIONS

Parameter	Typ	Unit
Input Pulse Levels	V _{IL} = 0, V _{IH} = 3.0	V
Input Rise and Fall	5	ns
Input and Output Reference Level	1.5	V
Output Timing Reference Level	1.5	V

NOTES:
V_Z is programmable from -2V to +7V.
I_{OL} & I_{OH} programmable from 0 to 16mA.
Tester Impedance Z₀ = 75 Ω.
V_Z is typically the midpoint of V_{OH} and V_{OL}.
I_{OL} & I_{OH} are adjusted to simulate a typical resistive load circuit.
ATE tester includes jig capacitance.

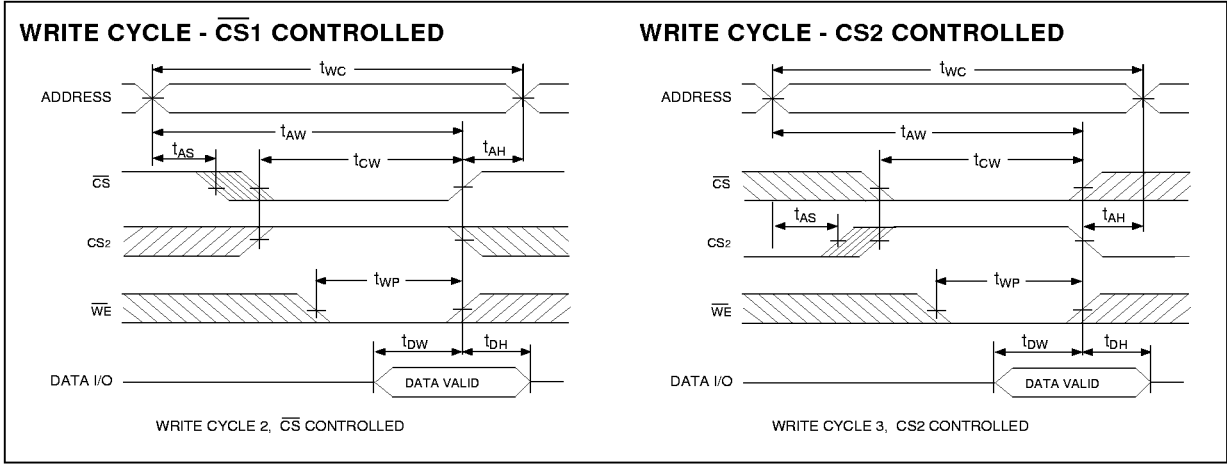
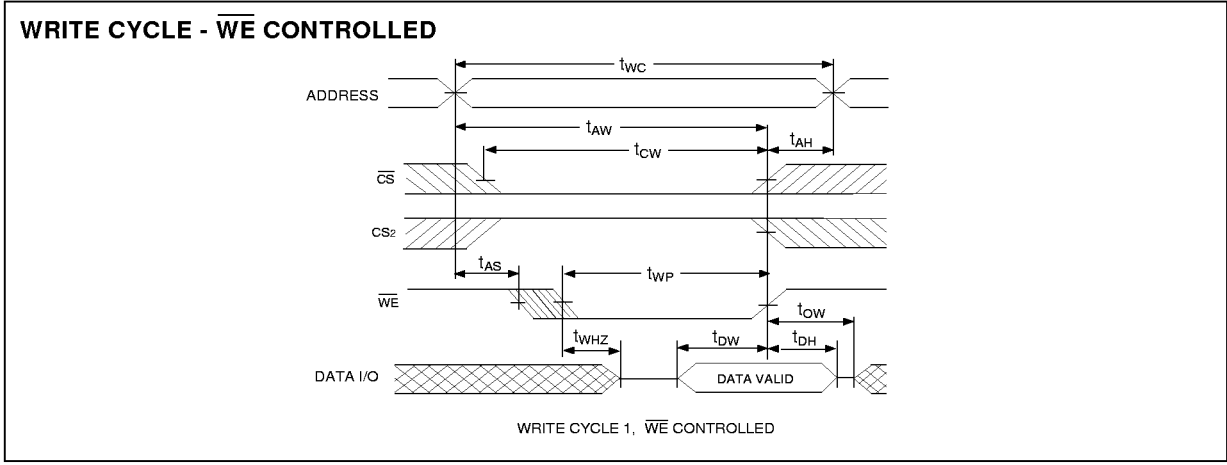
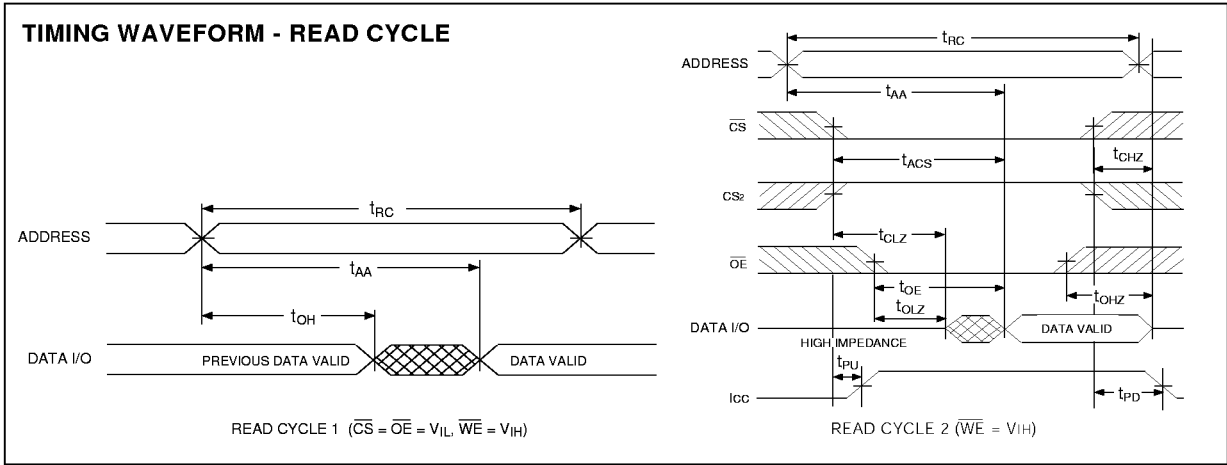



PACKAGE 101: 32 LEAD, CERAMIC SOJ

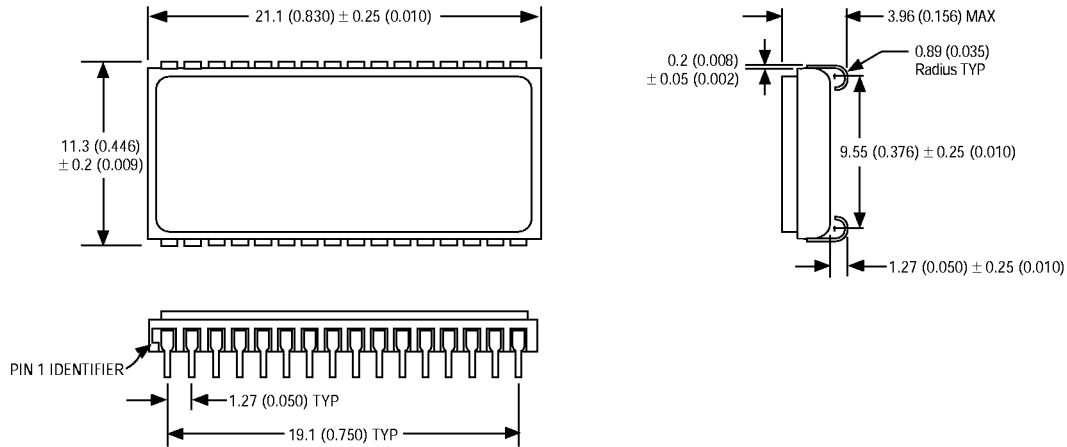

ALL LINEAR DIMENSIONS ARE MILLIMETERS AND PARENTHETICALLY IN INCHES

PACKAGE 206: 32 LEAD, CERAMIC FLAT PACK

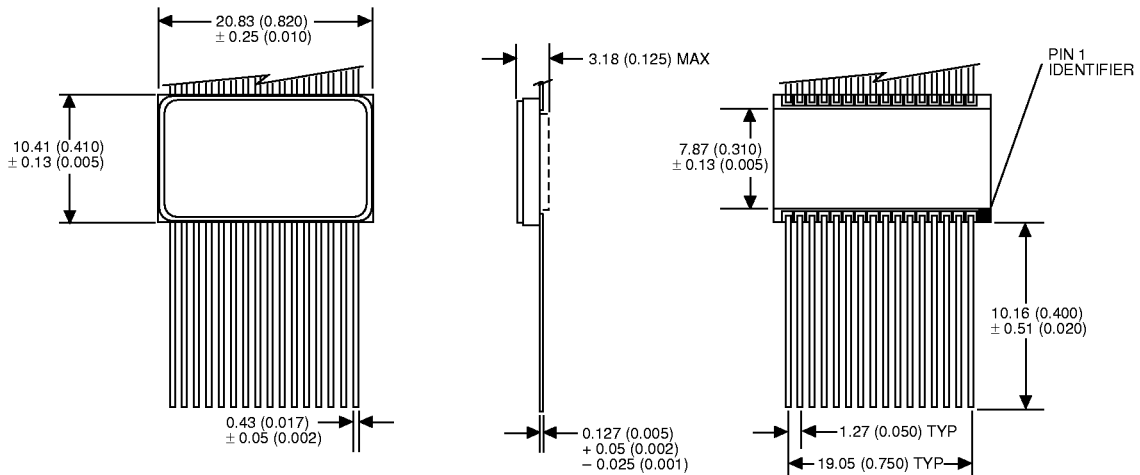

ALL LINEAR DIMENSIONS ARE MILLIMETERS AND PARENTHETICALLY IN INCHES



PACKAGE 300: 32 PIN, CERAMIC DIP, SINGLE CAVITY SIDE BRAZED

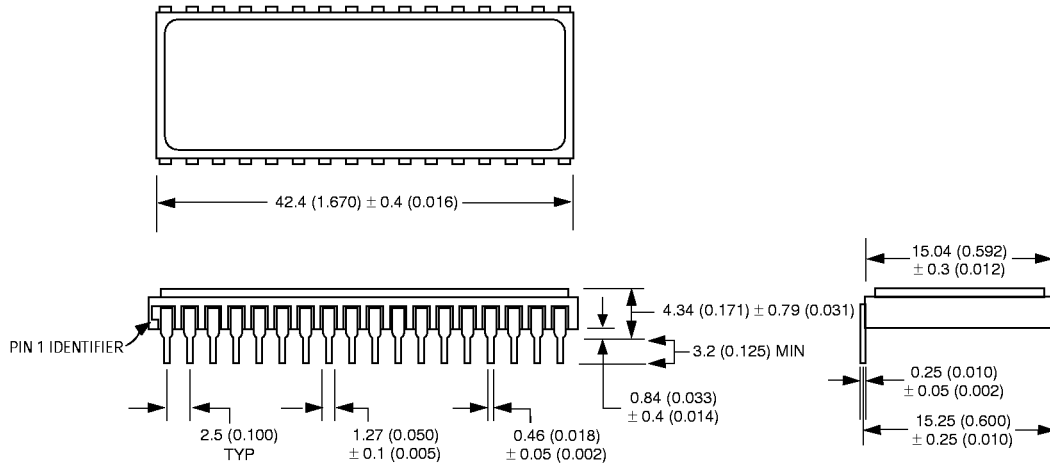

ALL LINEAR DIMENSIONS ARE MILLIMETERS AND PARENTHETICALLY IN INCHES



DATA RETENTION CHARACTERISTICS

(TA = -55°C to +125°C)

LOW POWER VERSION ONLY

Parameter	Symbol	Conditions	Units		
			Min	Max	
Data Retention Supply Voltage	V _{DR}	CS ₁ ≥ V _{CC} - 0.2V or CS ₂ ≥ V _{SS} + 0.2V	2.0	5.5	V
Data Retention Current	I _{CCDR2}	V _{CC} = 2V		2.5	mA
	I _{CCDR3}	V _{CC} = 3V		5.0	mA

ORDERING INFORMATION

W M S 128K8 X - XXX X X X X

LEAD FINISH:

- Blank = Gold plated leads
- A = Solder dip leads

SPECIAL PROCESSING:

- E = Epitaxial Layer

DEVICE GRADE:

- M = Military Screened -55°C to +125°C
- I = Industrial -40°C to +85°C
- C = Commercial 0°C to +70°C

PACKAGE:

- C = 32 Pin Ceramic .600" DIP (Package 300)
- DE = 32 Lead Ceramic SOJ (Package 101)
- FE = 32 Lead Ceramic Flat Pack (Package 206)

ACCESS TIME (ns)

IMPROVEMENT MARK

- C = Dual Chip Select Device
- L = Low Power for 2V Data Retention

ORGANIZATION, 128K x 8

SRAM

MONOLITHIC

WHITE MICROELECTRONICS