

**QUAD OPERATIONAL AMPLIFIERS**

The KA224 series consists of four independent, high gain, internally frequency compensated operational amplifiers which were designed specifically to operate from a single power supply over a wide voltage range.

Operation from split power supplies is also possible so long as the difference between the two supplies is 3 volts to 32 volts.

Application areas include transducer amplifier, DC gain blocks and all the conventional OP amp circuits which now can be easily implemented in single power supply systems.

**FEATURES**

- Internally frequency compensated for unity gain
- Large DC voltage gain: 100dB
- Wide power supply range: KA224/A, KA324/A: 3V-32V (or  $\pm 1.5 \sim 15V$ )  
KA2902: 3V-26V (or  $\pm 1.5V \sim 13V$ )
- Input common-mode voltage range includes ground
- Large output voltage swing: 0V DC to  $V_{CC} - 1.5V$  DC
- Power drain suitable for battery operation.

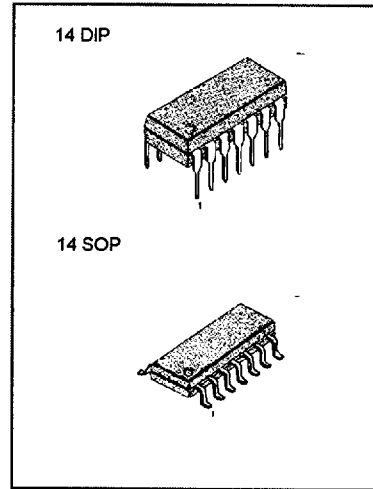

**BLOCK DIAGRAM**

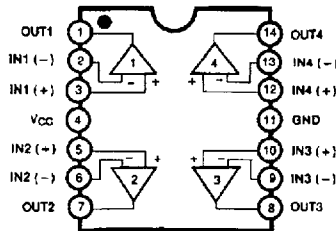

**ORDERING INFORMATION**

Device	Package	Operating Temperature
KA324 KA324A	14 DIP	0 ~ +70°C
KA324D KA324AD	14 SOP	
KA224 KA224A	14 DIP	-25 ~ +85°C
KA224D KA224AD	14 SOP	
KA2902	14 DIP	-40 ~ +85°C
KA2902D	14 SOP	

**SCHEMATIC DIAGRAM (One Section Only)**

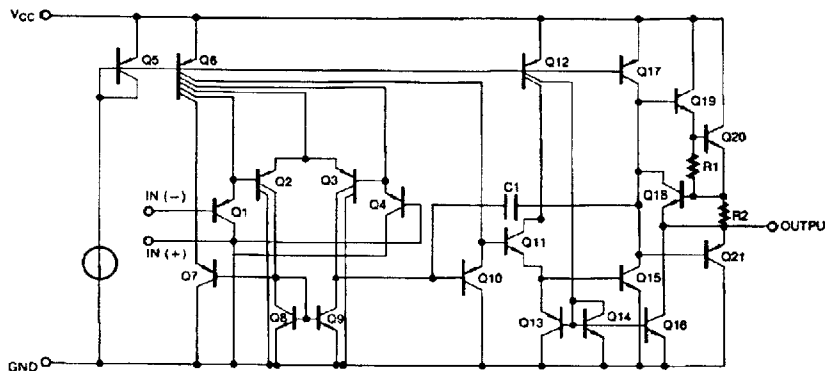

**ABSOLUTE MAXIMUM RATINGS**

Characteristic	Symbol	KA224/KA224A	KA324/KA324A	KA2902	Unit
Power Supply Voltage	V <sub>CC</sub>	± 18 or 32	± 18 or 32	± 13 or 26	V
Differential Input Voltage	V <sub>I(DIFF)</sub>	32	32	26	V
Input Voltage	V <sub>I</sub>	-0.3 to + 32	-0.3 to +32	-0.3 to +26	V
Output Short Circuit to GND		Continuous	Continuous	Continuous	
V <sub>CC</sub> ≤ 15V T <sub>A</sub> = 25°C (One Amp)					
Power Dissipation	P <sub>D</sub>	570	570	570	mW
Operating Temperature Range	T <sub>OPR</sub>	-25 ~ +85	0 ~ + 70	-40 ~ + 85	°C
Storage Temperature Range	T <sub>STG</sub>	-65 ~ + 150	-65 ~ + 150	-65 ~ + 150	°C

**ELECTRICAL CHARACTERISTICS**

(V<sub>CC</sub> = 5.0V, V<sub>EE</sub> = GND, T<sub>A</sub> = 25°C, unless otherwise specified)

Characteristic	Symbol	Test Conditions	KA224			KA324			KA2902			Unit
			Min	Typ	Max	Min	Typ	Max	Min	Typ	Max	
Input Offset Voltage	V <sub>IO</sub>	V <sub>CM</sub> = 0V to V <sub>CC</sub> = 1.5V V <sub>O(P)</sub> = 1.4V, R <sub>S</sub> = 0Ω		1.5	5.0		1.5	7.0		1.5	7.0	mV
Input Offset Current	I <sub>IO</sub>			2.0	30		3.0	50		3.0	50	nA
Input Bias Current	I <sub>BIAS</sub>			40	150		40	250		40	250	nA
Input Common-Mode Voltage Range	V <sub>I(R)</sub>	V <sub>CC</sub> = 30V (V <sub>CC</sub> = 26V for KA2902)	0		V <sub>CC</sub> -1.5	0	V <sub>CC</sub> -1.5		0		V <sub>CC</sub> -1.5	V
Supply Current	I <sub>CC</sub>	R <sub>L</sub> = ∞, V <sub>CC</sub> = 30V (all Amps)		1.0	3		1.0	3		1.0	3	mA
		R <sub>L</sub> = ∞, V <sub>CC</sub> = 5V (all Amps) (V <sub>CC</sub> = 26V for KA2902)		0.7	1.2		0.7	1.2		0.7	1.2	mA
Large Signal Voltage Gain	G <sub>V</sub>	V <sub>CC</sub> = 15V, R <sub>L</sub> ≥ 2KΩ V <sub>O(P)</sub> = 1V to 11V	50	100		25	100			100		V/mV
Output Voltage Swing	V <sub>O(P)</sub>	V <sub>CC</sub> = 30V V <sub>CC</sub> = 26V for 2902		26		26			22			V
	V <sub>O(L)</sub>	V <sub>CC</sub> = 5V, R <sub>L</sub> ≥ 10KΩ		5	20		5	20		5	100	mV
Common-Mode Rejection Ratio	CMRR		70	85		65	75		50	75		dB
Power Supply Rejection Ratio	PSRR		65	100		65	100		50	100		dB
Channel Separation	CS	f = 1KHz to 20KHz		120			120			120		dB
Short Circuit to GND	I <sub>SC</sub>			40	60		40	60		40	60	mA
Output Current	I <sub>SOURCE</sub>	V <sub>I(+)</sub> = 1V, V <sub>I(-)</sub> = 0V V <sub>CC</sub> = 15V, V <sub>O(P)</sub> = 2V	20	40		20	40		20	40		mA
	I <sub>SINK</sub>	V <sub>I(+)</sub> = 0V, V <sub>I(-)</sub> = 1V V <sub>CC</sub> = 15V, V <sub>O(P)</sub> = 2V	10	13		10	13		10	13		mA
		V <sub>I(+)</sub> = 0V, V <sub>I(-)</sub> = 1V V <sub>CC</sub> = 15V, V <sub>O(R)</sub> = 200mV	12	45		12	45					μA
Differential Input Voltage	V <sub>I(DIFF)</sub>				V <sub>CC</sub>				V <sub>CC</sub>			V

**ELECTRICAL CHARACTERISTICS**

( $V_{CC} = 5.0V$ ,  $V_{EE} = GND$ , unless otherwise specified)

The following specification apply over the range of  $-25^{\circ}C \leq T_A \leq +85^{\circ}C$  for the KA224; and the  $0^{\circ}C \leq T_A \leq +70^{\circ}C$  for the KA324 ; and the  $-40^{\circ}C \leq T_A \leq +85^{\circ}C$  for the KA2902

Characteristic	Symbol	Test Conditions	KA224			KA324			KA2909			Unit
			Min	Typ	Max	Min	Typ	Max	Min	Typ	Max	
Input Offset Voltage	$V_{IO}$	$V_{ICM} = 0V$ to $V_{CC} = 1.5V$ $V_{O(P)} = 1.4V$ , $R_S = 0\Omega$			7.0			9.0			10.0	mV
Input Offset Voltage Drift	$\Delta V_{IO}/\Delta T$			7.0			7.0			7.0		$\mu V/^{\circ}C$
Input Offset Current	$I_{IO}$				100			150			200	nA
Input Offset Current Drift	$\Delta I_{IO}/\Delta T$			10			10			10		$\mu A/^{\circ}C$
Input Bias Current	$I_{BIAS}$				300			500			500	nA
Input Common-Mode Voltage Range	$V_{IC(R)}$	$V_{CC} = 30V$ ( $V_{CC} = 26V$ for LM2902)	0		$V_{CC} - 2.0$	0		$V_{CC} - 2.0$	0		$V_{CC} - 2.0$	V
Large Signal Voltage Gain	$G_V$	$V_{CC} = 15V$ , $R_L \geq 2.0K\Omega$ $V_{O(P)} = 1V$ to $11V$	25			15			15			V/mV
Output Voltage Swing	$V_{OH}$	$V_{CC} = 30V$ $V_{CC} = 26V$ for 2902	26			26			22			V
	$V_{OL}$	$V_{CC} = 5V$ , $R_L \geq 10K\Omega$	5	20		5	20		5	100		mV
Output Current	$I_{SOURCE}$	$V_{I(+)} = 1V$ , $V_{I(-)} = 0V$ $V_{CC} = 15V$ , $V_{O(P)} = 2V$	10	20		10	20		10	20		mA
	$I_{SINK}$	$V_{I(+)} = 0V$ , $V_{I(-)} = 1V$ $V_{CC} = 15V$ , $V_{O(P)} = 2V$	10	13		5	8		5	8		mA
Differential Input Voltage	$V_{I(DIFS)}$				$V_{CC}$			$V_{CC}$			$V_{CC}$	V

**ELECTRICAL CHARACTERISTICS**

( $V_{CC}=50V$ ,  $V_{EE}=GND$ ,  $T_A=25^\circ C$ , unless otherwise specified)

Characteristic	Symbol	Test Conditions	KA224A			KA324A			Unit
			Min	Typ	Max	Min	Typ	Max	
Input Offset Voltage	$V_{IO}$	$V_{CM} = 0V$ to $V_{CC} = 1.5V$ $V_{O(P)} = 1.4V$ , $R_S = 0$		1.0	3.0		1.5	3.0	mV
Input Offset Current	$I_{IO}$			2	15		3.0	30	nA
Input Bias Current	$I_{BIAS}$			40	80		40	100	nA
Input Common-Mode Voltage Range	$V_{I(R)}$	$V_{CC} = 30V$	0		$V_{CC} - 1.5$	0		$V_{CC} - 1.5$	V
Supply Current (All Amps)	$I_{CC}$	$V_{CC} = 30V$		1.5	3		1.5	3	mA
		$V_{CC} = 5V$		0.7	1.2		0.7	1.2	mA
Large Signal Voltage Gain	$G_V$	$V_{CC} = 15V$ , $R_L \geq 2K\Omega$ $V_{O(P)} = 1V$ to $11V$	50	100		25	100		V/mV
Output Voltage Swing	$V_{O(H)}$	$V_{CC} = 30V$		26		26			V
		$V_{CC} = 26V$ for 2902		27	28		27	28	V
	$V_{O(L)}$	$V_{CC} = 5V$ , $R_L \geq 10K\Omega$		5	20		5	20	mV
Common-Mode Rejection Ratio	CMRR		70	85		65	85		dB
Power Supply Rejection Ratio	PSRR		65	100		65	100		dB
Channel Separation	CS	$f = 1KHz$ to $20KHz$		120			120		dB
Short Circuit to GND	$I_{SC}$			40	60		40	60	mA
Output Current	$I_{SOURCE}$	$V_{I(+)} = 1V$ , $V_{I(-)} = 0V$ $V_{CC} = 15V$	20	40		20	40		mA
		$V_{I(+)} = 0V$ , $V_{I(-)} = 1V$ $V_{CC} = 15V$ , $V_{O(P)} = 2V$	10	20		10	20		mA
	$I_{SINK}$	$V_{I(+)} = 0V$ , $V_{I(-)} = 1V$ $V_{CC} = 15V$ , $V_{O(P)} = 200mV$	12	50		12	50		$\mu A$
Differential Input Voltage	$V_{I(DIFF)}$				$V_{CC}$			$V_{CC}$	V

**ELECTRICAL CHARACTERISTICS**

( $V_{CC} = 5.0V$ ,  $V_{EE} = GND$ , unless otherwise specified)

The following specification apply over the range of  $-25^{\circ}C \leq T_A \leq +85^{\circ}C$  for the KA224A; and the  $0^{\circ}C \leq T_A \leq +70^{\circ}C$  for the KA324A

Characteristic	Symbol	Test Conditions	KA224A			KA324A			Unit
			Min	Typ	Max	Min	Typ	Max	
Input Offset Voltage	$V_{IO}$	$V_{CM} = 0V$ to $V_{CC} = 1.5V$ $V_{O(P)} = 1.4V$ , $R_S = 0\Omega$			4.0			5.0	mV
Input Offset Voltage Drift	$\Delta V_{IO}/\Delta T$			7.0	20		7.0	30	$\mu V/^{\circ}C$
Input Offset Current	$I_{IO}$				30			75	nA
Input Offset Current Drift	$\Delta I_{IO}/\Delta T$			10	200		10	300	$\mu A/^{\circ}C$
Input Bias Current	$I_{BIAS}$			40	100		40	200	nA
Input Common-Mode Voltage Range	$V_{I(R)}$	$V_{CC} = 30V$	0		$V_{CC}$ -2.0	0		$V_{CC}$ -2.0	V
Large Signal Voltage Gain	$G_V$	$V_{CC} = 15V$ , $R_L \geq 2.0K\Omega$	25			15			V/mV
Output Voltage Swing	$V_{O(P-P)}$	$V_{CC} = 30V$	$R_L = 2K\Omega$	26			26		V
			$R_L = 10K\Omega$	27	28		27	28	
		$V_{CC} = 5V$ , $R_L \leq 10K\Omega$		5	20		5	20	mA
Output Current	$I_{SOURCE}$	$V_{I(+)} = 1V$ , $V_{I(-)} = 0V$ $V_{CC} = 15V$	10	20		10	20		mA
	$I_{SINK}$	$V_{I(+)} = 0V$ , $V_{I(-)} = 1V$ $V_{CC} = 15V$	5	8		5	8		mA
Differential Input Voltage	$V_{I(DIFF)}$				$V_{CC}$			$V_{CC}$	V

Fig. 1 INPUT VOLTAGE RANGE

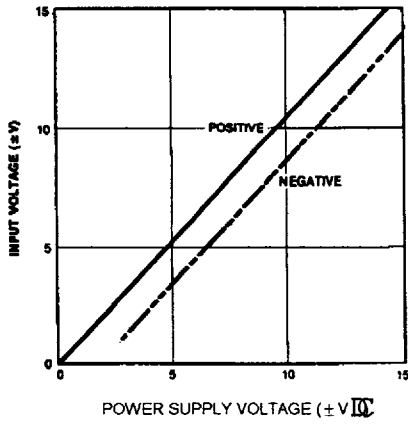

Fig. 3 SUPPLY CURRENT

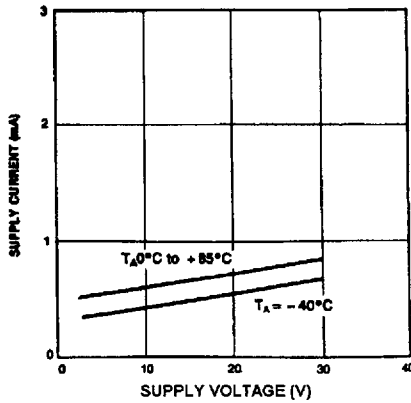

Fig. 5 OPEN LOOP FREQUENCY RESPONSE

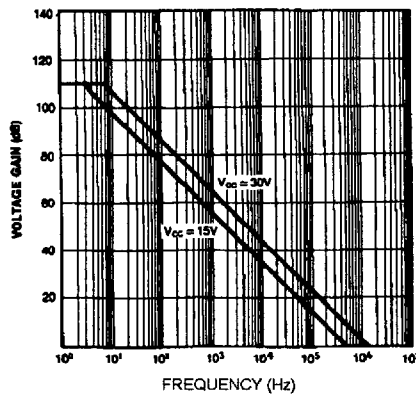

Fig. 2 INPUT CURRENT

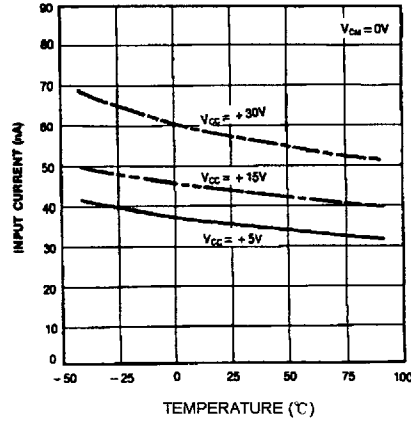

Fig. 4 VOLTAGE GAIN

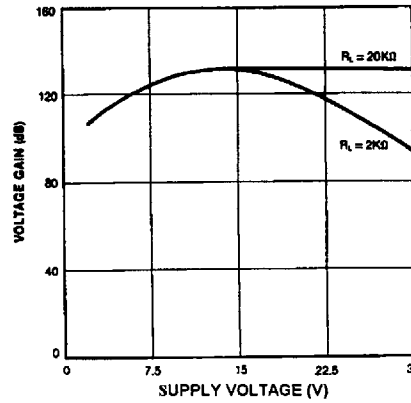
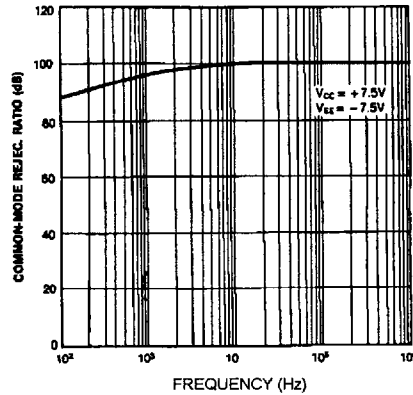

Fig. 6 COMMON-MODE REJECTION RATIO



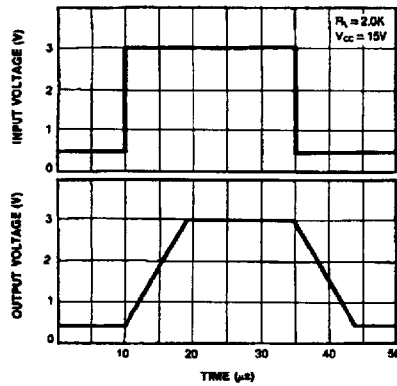

Fig. 9 LARGE SIGNAL FREQUENCY RESPONSE

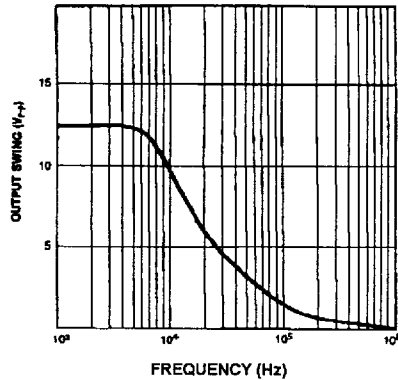

Fig. 11 OUTPUT CHARACTERISTICS  
CURRENT SINKING

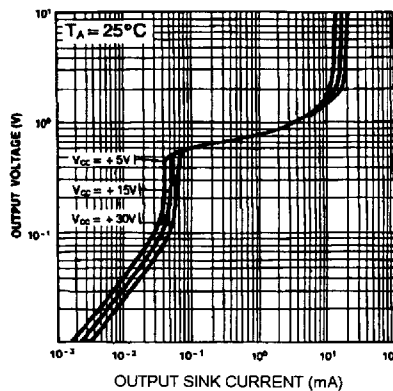

Fig. 8 VOLTAGE FOLLOWER PULSE  
RESPONSE (SMALL SIGNAL)

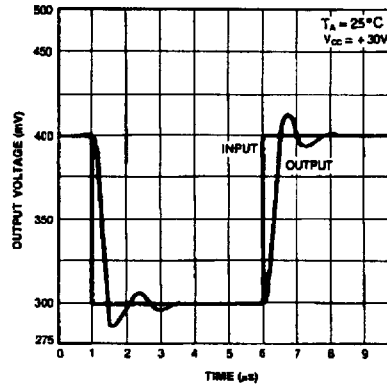

Fig. 10 OUTPUT CHARACTERISTICS  
CURRENT SOURCING

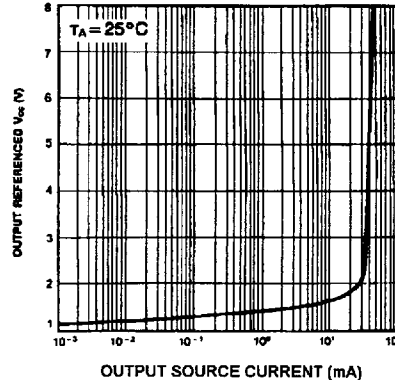
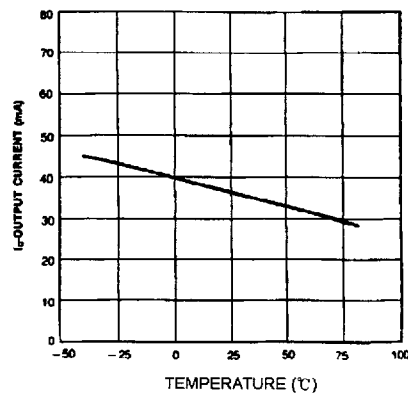
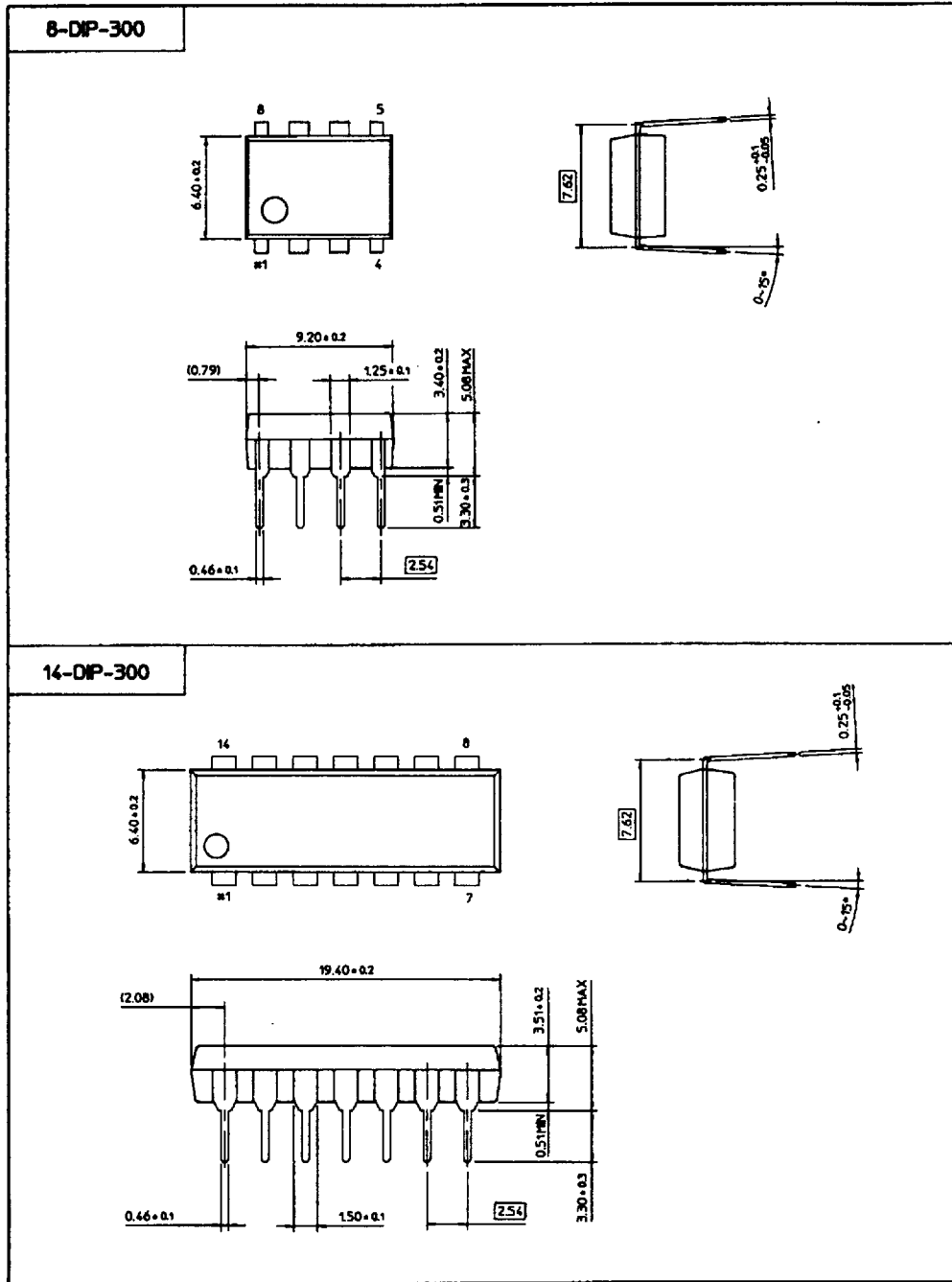

Fig. 12 CURRENT LIMITING



Dimensions in Millimeters





8-SOP-225

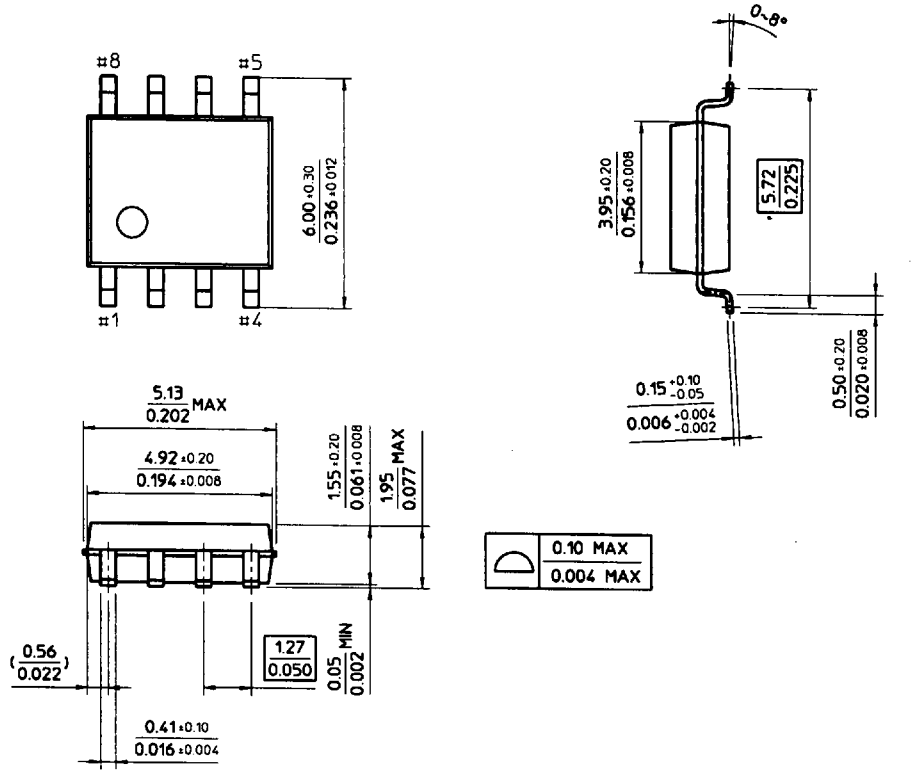

14-SOP-225B

