

UT54ACS163/UT54ACTS163

Radiation-Hardened 4-Bit Synchronous Counters

FEATURES

- Internal look-ahead for fast counting
- Carry output for n-bit cascading
- Synchronous counting
- Synchronously programmable
- 1.2 μ radiation-hardened CMOS
 - Latchup immune
- High speed
- Low power consumption
- Single 5 volt supply
- Available QML Q or V processes
- Flexible package
 - 16-pin DIP
 - 16-lead flatpack

DESCRIPTION

The UT54ACS163 and the UT54ACTS163 are synchronous presettable 4-bit binary counters that feature internal carry look-ahead logic for high-speed counting designs. Synchronous operation occurs by having all flip-flops clocked simultaneously so that the outputs change coincident with each other when instructed by the count-enable inputs and internal gating. A buffered clock input triggers the four flip-flops on the rising (positive-going) edge of the clock input waveform.

The counters are fully programmable (i.e., they may be preset to any number between 0 and 15). Presetting is synchronous; applying a low level at the load input disables the counter and causes the outputs to agree with the load data after the next clock pulse.

The clear function is synchronous and a low level at the clear input sets all four of the flip-flop outputs low after the next clock pulse. This synchronous clear allows the count length to be modified by decoding the Q outputs for the maximum count desired.

The counters feature a fully independent clock circuit. Changes at control inputs (ENP, ENT, or \overline{LOAD}) that modify the operating mode have no effect on the contents of the counter until clocking occurs. The function of the counter (whether enabled, disabled, loading, or counting) will be dictated solely by the conditions meeting the stable setup and hold times.

The devices are characterized over full military temperature range of -55°C to +125°C.

PINOUTS

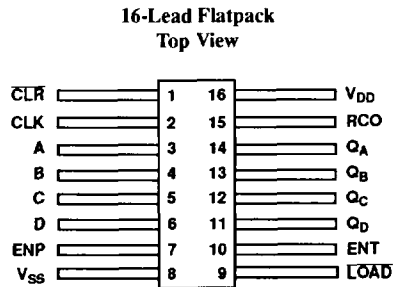
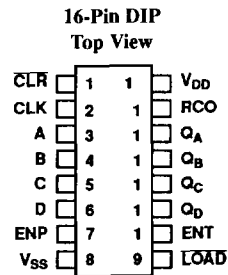

LOGIC SYMBOL

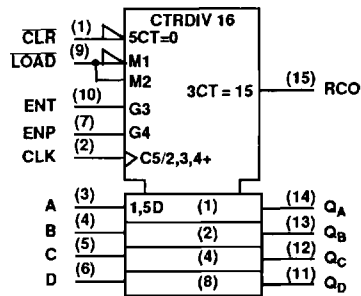

Note:
These symbols are in accordance with ANSI/IEEE Std 91-1984 and IEC Publication 617-12.

FUNCTION TABLE

Operating Mode	$\overline{\text{CLR}}$	CLK	ENP	ENT	$\overline{\text{LOAD}}$	DATA A,B,C,D	Q_N	RCO
Reset (Clear)	L	\uparrow	X	X	X	X	L	L
Parallel Load	h^3	\uparrow	X	X	L	L	L	L
	h^3	\uparrow	X	X	L	h	H	L_1
Count	h^3	\uparrow	h	h	h	X	Count	1
Inhibit	h^3	X	L^2	X	h^3	X	Q_N	1
	h^3	X	X	L^2	h^3	X	Q_N	L

H = High voltage level h = High voltage level one setup time prior to the low-to-high clock transition

L = Low voltage level l = Low voltage level one setup time prior to the low-to-high clock transition

Notes:

1. The RCO output is high when ENT is high and the counter is at terminal count HHHH.
2. The high-to-low transition of ENP or ENT should only occur while CLK is high for conventional operations.
3. The low-to-high transition of $\overline{\text{LOAD}}$ or $\overline{\text{CLR}}$ should only occur while CLK is high for conventional operations.

LOGIC DIAGRAM

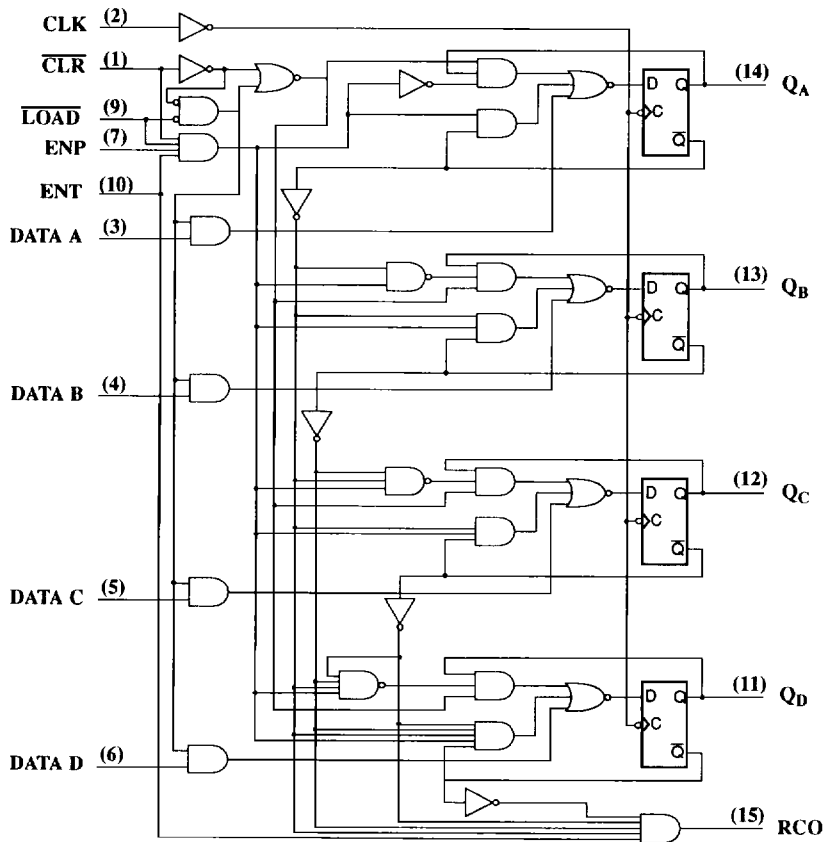

RADIATION HARDNESS SPECIFICATIONS ¹

PARAMETER	LIMIT	UNITS
Total Dose	1.0E6	rads(Si)
SEU & SEL Threshold ²	80	MeV-cm ² /mg
Neutron Fluence	1.0E14	n/cm ²

Notes:

- Logic will not latchup during radiation exposure within the limits defined in the table.
- Device storage elements are immune to SEU affects.

ABSOLUTE MAXIMUM RATINGS

SYMBOL	PARAMETER	LIMIT	UNITS
V _{DD}	Supply voltage	0.3 to 7.0	V
V _{I/O}	Voltage any pin	-.3 to V _{DD} +.3	V
T _{STG}	Storage Temperature range	-65 to +150	°C
T _J	Maximum junction temperature	+175	°C
T _{LS}	Lead temperature (soldering 5 seconds)	+300	°C
Θ _{JC}	Thermal resistance junction to case	20	°C/W
I _I	DC input current	±10	mA
P _D	Maximum power dissipation	1	W

Note:

- Stresses outside the listed absolute maximum ratings may cause permanent damage to the device. This is a stress rating only, functional operation of the device at these or any other conditions beyond limits indicated in the operational sections is not recommended. Exposure to absolute maximum rating conditions for extended periods may affect device reliability.

RECOMMENDED OPERATING CONDITIONS

SYMBOL	PARAMETER	LIMIT	UNITS
V _{DD}	Supply voltage	4.5 to 5.5	V
V _{IN}	Input voltage any pin	0 to V _{DD}	V
T _C	Temperature range	-55 to + 125	°C

DC ELECTRICAL CHARACTERISTICS⁷(V_{DD} = 5.0V ±10%; V_{SS} = 0V⁶, -55°C < T_C < +125°C)

SYMBOL	PARAMETER	CONDITION	MIN	MAX	UNIT
V _{IL}	Low-level input voltage ¹ ACTS ACS			0.8 .3V _{DD}	V
V _{IH}	High-level input voltage ¹ ACTS ACS		.5V _{DD} .7V _{DD}		V
I _{IN}	Input leakage current ACTS/ACS	V _{IN} = V _{DD} or V _{SS}	-1	1	μA
V _{OL}	Low-level output voltage ³ ACTS ACS	I _{OL} = 8.0mA I _{OL} = 100μA		0.40 0.25	V
V _{OH}	High-level output voltage ³ ACTS ACS	I _{OH} = -8.0mA I _{OH} = -100μA	.7V _{DD} V _{DD} - 0.25		V
I _{OS}	Short-circuit output current ^{2,4} ACTS/ACS	V _O = V _{DD} and V _{SS}	-200	200	mA
P _{total}	Power dissipation ^{8,9}	C _L = 50pF		1.9	mW/MHz
I _{DDQ}	Quiescent Supply Current	V _{DD} = 5.5V		10	μA
C _{IN}	Input capacitance ⁵	f = 1MHz @ 0V		15	pF
C _{OUT}	Output capacitance ⁵	f = 1MHz @ 0V		15	pF

Notes:

- Functional tests are conducted in accordance with MIL-STD-883 with the following input test conditions: V_{IH} = V_{IH}(min) + 20%, - 0%; V_{IL} = V_{IL}(max) + 0%, - 50%, as specified herein, for TTL, CMOS, or Schmitt compatible inputs. Devices may be tested using any input voltage within the above specified range, but are guaranteed to V_{IH}(min) and V_{IL}(max).
- Supplied as a design limit but not guaranteed or tested.
- Per MIL-M-38510, for current density ≤ 5.0E5 amps/cm², the maximum product of load capacitance (per output buffer) times frequency should not exceed 3,765 pF MHz.
- Not more than one output may be shorted at a time for maximum duration of one second.
- Capacitance measured for initial qualification and when design changes may affect the value. Capacitance is measured between the designated terminal and V_{SS} at frequency of 1MHz and a signal amplitude of 50mV rms maximum.
- Maximum allowable relative shift equals 50mV.
- All specifications valid for radiation dose ≤ 1E6 rads(Si).
- Power does not include power contribution of any TTL output sink current.
- Power dissipation specified per switching output.

UT54ACS163/UT54ACTS163

AC ELECTRICAL CHARACTERISTICS ²

(V_{DD} = 5.0V ±10%; V_{SS} = 0V ¹, -55°C < T_C < +125°C)

SYMBOL	PARAMETER	MINIMUM	MAXIMUM	UNIT
t _{PHL}	CLK to Q _n	1	24	ns
t _{PLH}	CLK to Q _n	1	22	ns
t _{PHL}	CLK to RCO	1	22	ns
t _{PLH}	CLK to RCO	1	24	ns
t _{PHL}	ENT to RCO	1	13	ns
t _{PLH}	ENT to RCO	1	14	ns
f _{MAX}	Maximum clock frequency		77	MHz
t _{SU}	Setup time before CLK ↑ A, B, C, D LOAD ENP, ENT CLR low CLR high	6		ns
t _H	Data hold time after CLK ↑ All synchronous inputs	1		ns
t _W	Minimum pulse width CLR low CLK high CLK low	7		ns

Notes:

1. Maximum allowable relative shift equals 50mV.
2. All specifications valid for radiation dose ≤ 1E6 rads(Si).