

DESCRIPTION & FEATURES 概述及特點	
<p>The FH78LXX series of three terminal positive regulators is available with several fixed output voltages making them useful in a wide range of applications. FH78LXX can use as a zener diode/resistor combination replacement, and lower quiescent current. These devices suitable for a multitude of applications that require a regulated supply of up to 100 mA. The voltages available allow the FH78LXX to be used in logic systems, instrumentation, HiFi, and other solid state electronic equipment. circuit takes over preventing the IC from overheating.</p>	<p>FH78LXX 系列三端穩壓器有效利用幾個固定電壓得到較寬的應用範圍，可替代混合的齊納二極體和電阻時，而且更低的靜態電流。適合 100mA 的各種穩壓要求。FH78LXX 這些電壓可以用在邏輯系統，檢測儀器，HIFI，和其他點子設備。可以替代過熱保護 IC。</p>
<p>Package SOT-89 Output voltage tolerances of <math>\pm 5\%</math> over the temperature range Output current of 100mA Internal thermal overload protection Output voltages of 5.0V, 6.0V, 8.0V, 9.0V, 12V, 15V, 18V</p>	<p>封裝：SOT-89 輸出電壓精度<math>\pm 5\%</math>  輸出電流 100mA 內置過流保護功能 輸出電壓5.0V, 6.0V, 8.0V, 9.0V, 12V, 15V, 18V</p>

Pin Configuration 管腳配置

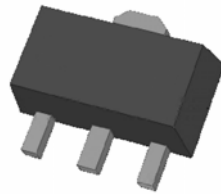

1.Vout 2.Gnd 3.Vin

Type Name 型號命名

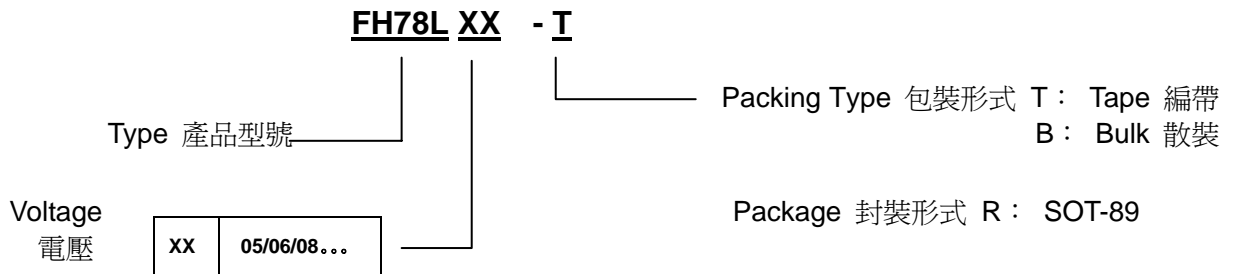

TYPE No.	MARKING	TYPE No.	MARKING	TYPE No.	MARKING
FH78L05	8A	FH78L09	8E	FH78L15	8I
FH78L06	8B	FH78L10	8F	FH78L18	8J
FH78L07	8C	FH78L12	8G	FH78L20	8K
FH78L08	8D	FH78L13	8H	FH78L24	8L

BLOCK DIAGRAM 功能框圖

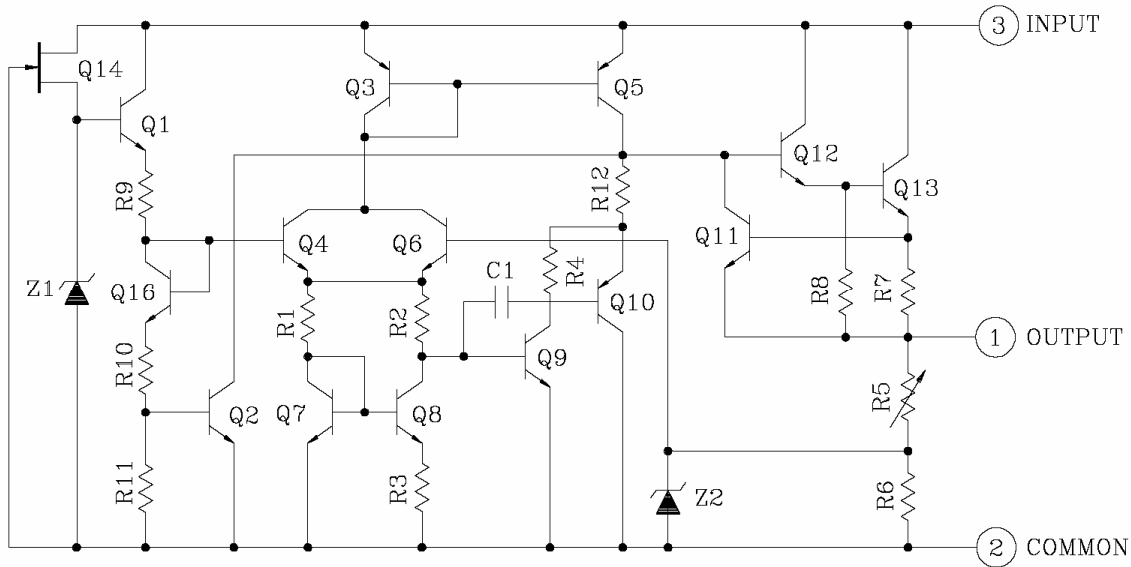

ABSOLUTE MAXIMUM RATINGS ( $T_a=25^\circ\text{C}$ ) 最大額定值 (Note)

Characteristic 特性參數	Symbol 符號	Rating 額定值		Unit 單位
		Min 最小	Max 最大	
Power dissipation	$P_D$		0.5	W
Input Voltage (5~15V) (18~24V)	$V_{IN}$		35 40	V
Operating Temperature Range 工作溫度範圍	$T_{opt}$	-0	125	$^\circ\text{C}$
Storage Temperature Range 儲存溫度範圍	$T_{stg}$	-55	150	$^\circ\text{C}$

Note : Absolute maximum ratings are threshold limit values that must not be exceeded ever for an instant under any conditions. Moreover, such values for any two items must not be reached simultaneously. Operation above these absolute maximum ratings may cause degradation or permanent damage to the device. These are stress ratings only and do not necessarily imply functional operation below these limits.

注意：絕對最大值是一個極限值，在任何情況下即使極短的時間亦不能被超過。而且，任何兩項的絕對值都不能同時達到極限。任何超越最大值操作，將會引起器件永久損壞。這僅僅是重要的範圍值，但並不意味著所有的功能操作必須在此極限值下去做。

Typical Applications 典型應用圖例

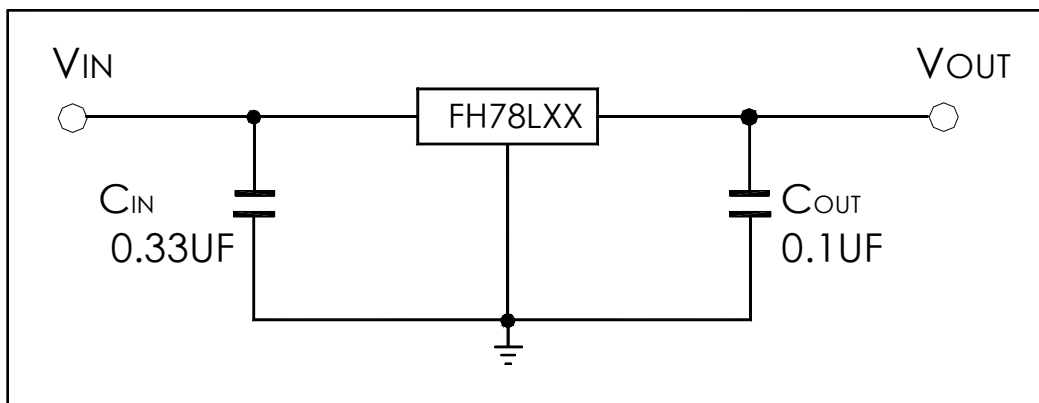

THREE TERMINAL POSITIVE VOLTAGE REGULATORS

三端穩壓器 FH78LXX

ELECTRICAL CHARACTERISTICS

FH78L05

Unless otherwise specified,  $V_{in}=10V$ ,  $I_{out}=40mA$ ,  $C_{in}=0.33\mu F$ ,  $C_{out}=0.1\mu F$ ,  $T_j=0^{\circ}C$  to  $125^{\circ}C$

CHARACTERISTIC	SYMBOL	TEST CONDITION		MIN.	TYP.	MAX.	UNIT
Output Voltage	$V_{out}$	$T_j=25^{\circ}C$		4.75	5.0	5.25	V
Input Regulation	Reg line	$T_j=25^{\circ}C$	$7.0V \leq V_{in} \leq 20V$	-	55	150	mV
			$8.0V \leq V_{in} \leq 20V$	-	45	100	
Load Regulation	Reg load	$T_j=25^{\circ}C$	$1.0mA \leq I_{out} \leq 100mA$	-	11	60	mV
			$1.0mA \leq I_{out} \leq 40mA$	-	5.0	30	
Output Voltage	$V_{out}$	$7.0V \leq V_{in} \leq 20V$ $1.0mA \leq I_{out} \leq 40mA$		4.65	-	5.3	V
		$V_{in}=10V, 1.0mA \leq I_{out} \leq 70mA$		4.65	-	5.3	
Quiescent Current	$I_Q$	$T_j=25^{\circ}C$		-	3.1	6.0	mA
		$T_j=125^{\circ}C$		-	-	5.5	
Quiescent Current Change	$\Delta I_Q$	$8.0V \leq V_{in} \leq 20V$		-	-	1.5	mA
		$1.0mA \leq I_{out} \leq 40mA$		-	-	0.1	
Output Noise Voltage	$V_{NO}$	$T_a=25^{\circ}C, 10Hz \leq f \leq 100kHz$		-	40	-	$\mu V_{rms}$
Long Term Stability	$\Delta V_{out}/\Delta t$			-	12	-	mV/1.0kHrs
Ripple Rejection Ratio	RR	$f=120Hz, 8.0V \leq V_{in} \leq 18V, T_j=25^{\circ}C$		41	49	-	dB
Dropout Voltage	$ V_{in}-V_{out} $	$T_j=25^{\circ}C$			1.7		V
Average Temperature Coefficient of Output Voltage	TCvo	$I_{out}=5mA$		-	-0.6	-	mV/ $^{\circ}C$

**THREE TERMINAL POSITIVE VOLTAGE REGULATORS**      **三端穩壓器 FH78LXX**

**ELECTRICAL CHARACTERISTICS**

**FH78L06**

Unless otherwise specified,  $V_{in}=11V$ ,  $I_{out}=40mA$ ,  $C_{in}=0.33\mu F$ ,  $C_{out}=0.1\mu F$ ,  $T_j=0^{\circ}C$  to  $125^{\circ}C$

CHARACTERISTIC	SYMBOL	TEST CONDITION		MIN.	TYP.	MAX.	UNIT
Output Voltage	$V_{out}$	$T_j=25^{\circ}C$		5.7	6.0	6.3	V
Input Regulation	Reg line	$T_j=25^{\circ}C$	$8.1V \leq V_{in} \leq 21V$	-	50	150	mV
			$9.0V \leq V_{in} \leq 21V$ ,	-	45	110	
Load Regulation	Reg load	$T_j=25^{\circ}C$	$1.0mA \leq I_{out} \leq 100mA$	-	12	70	mV
			$1.0mA \leq I_{out} \leq 40mA$	-	5.5	35	
Output Voltage	$V_{out}$	$8.1V \leq V_{in} \leq 21V$ $1.0mA \leq I_{out} \leq 40mA$		5.58	-	6.42	V
		$V_{in}=11V, 1.0mA \leq I_{out} \leq 70mA$		5.58	-	6.42	
Quiescent Current	$I_Q$	$T_j=25^{\circ}C$		-	3.1	6.0	mA
		$T_j=125^{\circ}C$		-	-	5.5	
Quiescent Current Change	$\Delta I_Q$	$9.0V \leq V_{in} \leq 19V$ ,		-	-	1.5	mA
		$1.0mA \leq I_{out} \leq 40mA$		-	-	0.1	
Output Noise Voltage	$V_{NO}$	$T_a=25^{\circ}C, 10Hz \leq f \leq 100kHz$		-	40	-	$\mu V_{rms}$
Long Term Stability	$\Delta V_{out}/\Delta t$			-	14	-	mV/1.0kHrs
Ripple Rejection Ratio	RR	$F=120Hz$ , $9.0V \leq V_{in} \leq 19V$ , $T_j=25^{\circ}C$		39	47	-	dB
Dropout Voltage	$ V_{in}-V_{out} $	$T_j=25^{\circ}C$			1.7		V
Average Temperature Coefficient of Output Voltage	$TC_{vo}$	$I_{out}=5mA$		-	-0.7	-	$mV/^{\circ}C$

THREE TERMINAL POSITIVE VOLTAGE REGULATORS

三端穩壓器 FH78LXX

ELECTRICAL CHARACTERISTICS

FH78L07

Unless otherwise specified,  $V_{in}=12V$ ,  $I_{out}=40mA$ ,  $C_{in}=0.33\mu F$ ,  $C_{out}=0.1\mu F$ ,  $T_j=0^{\circ}C$  to  $125^{\circ}C$

CHARACTERISTIC	SYMBOL	TEST CONDITION		MIN.	TYP.	MAX.	UNIT
Output Voltage	$V_{out}$	$T_j=25^{\circ}C$		6.72	7.0	7.28	V
Input Regulation	Reg line	$T_j=25^{\circ}C$	$9.2V \leq V_{in} \leq 22V$ ,	-	50	160	mV
			$10V \leq V_{in} \leq 22V$ ,	-	45	115	
Load Regulation	Reg load	$T_j=25^{\circ}C$	$1.0mA \leq I_{out} \leq 100mA$	-	13	75	mV
			$1.0mA \leq I_{out} \leq 40mA$	-	6.0	40	
Output Voltage	$V_{out}$	$9.2V \leq V_{in} \leq 22V$ , $1.0mA \leq I_{out} \leq 40mA$		6.65	-	7.35	V
		$V_{in}=12V$ , $1.0mA \leq I_{out} \leq 70mA$		6.65	-	7.35	
Quiescent Current	$I_Q$	$T_j=25^{\circ}C$		-	3.1	6.5	mA
		$T_j=125^{\circ}C$		-	-	6.0	
Quiescent Current Change	$\Delta I_Q$	$10V \leq V_{in} \leq 22V$ ,		-	-	1.5	mA
		$1.0mA \leq I_{out} \leq 40mA$		-	-	0.1	
Output Noise Voltage	$V_{NO}$	$T_a=25^{\circ}C$ , $10Hz \leq f \leq 100kHz$		-	50	-	$\mu V_{rms}$
Long Term Stability	$\Delta V_{out}/\Delta t$			-	17	-	mV/1.0kHrs
Ripple Rejection Ratio	RR	$F=120Hz$ , $10V \leq V_{in} \leq 20V$ , $T_j=25^{\circ}C$		37	46	-	dB
Dropout Voltage	$ V_{in}-V_{out} $	$T_j=25^{\circ}C$			1.7		V
Average Temperature Coefficient of Output Voltage	$TC_{vo}$	$I_{out}=5mA$			-0.75	-	$mV/^{\circ}C$

**THREE TERMINAL POSITIVE VOLTAGE REGULATORS**      **三端穩壓器 FH78LXX**

**ELECTRICAL CHARACTERISTICS**

**FH78L08**

Unless otherwise specified,  $V_{in}=14V$ ,  $I_{out}=40mA$ ,  $C_{in}=0.33\mu F$ ,  $C_{out}=0.1\mu F$ ,  $T_j=0^{\circ}C$  to  $125^{\circ}C$

CHARACTERISTIC	SYMBOL	TEST CONDITION		MIN.	TYP.	MAX.	UNIT
Output Voltage	$V_{out}$	$T_j=25^{\circ}C$		7.6	8.0	8.4	V
Input Regulation	Reg line	$T_j=25^{\circ}C$	$10.5V \leq V_{in} \leq 23V$ ,	-	20	175	mV
			$11V \leq V_{in} \leq 23V$ ,	-	12	125	
Load Regulation	Reg load	$T_j=25^{\circ}C$	$1.0mA \leq I_{out} \leq 100mA$	-	15	80	mV
			$1.0mA \leq I_{out} \leq 40mA$	-	7.0	40	
Output Voltage	$V_{out}$	$10.5V \leq V_{in} \leq 23V$ , $1.0mA \leq I_{out} \leq 40mA$		7.44	-	8.56	V
		$V_{in}=14V$ , $1.0mA \leq I_{out} \leq 70mA$		7.44	-	8.56	
Quiescent Current	$I_Q$	$T_j=25^{\circ}C$		-	3.1	6.5	mA
		$T_j=125^{\circ}C$		-	-	6.0	
Quiescent Current Change	$\Delta I_Q$	$11V \leq V_{in} \leq 23V$ ,		-	-	1.5	mA
		$1.0mA \leq I_{out} \leq 40mA$		-	-	0.1	
Output Noise Voltage	$V_{NO}$	$T_a=25^{\circ}C$ , $10Hz \leq f \leq 100kHz$		-	60	-	$\mu V_{rms}$
Long Term Stability	$\Delta V_{out}/\Delta t$			-	20	-	mV/1.0kHrs
Ripple Rejection Ratio	RR	$F=120Hz$ , $12V \leq V_{in} \leq 23V$ , $T_j=25^{\circ}C$		37	45	-	dB
Dropout Voltage	$ V_{in}-V_{out} $	$T_j=25^{\circ}C$			1.7		V
Average Temperature Coefficient of Output Voltage	$TC_{vo}$	$I_{out}=5mA$		-	-0.8	-	$mV/^{\circ}C$

**THREE TERMINAL POSITIVE VOLTAGE REGULATORS**      **三端穩壓器 FH78LXX**

**ELECTRICAL CHARACTERISTICS**

**FH78L09**

Unless otherwise specified,  $V_{in}=15V$ ,  $I_{out}=40mA$ ,  $C_{in}=0.33\mu F$ ,  $C_{out}=0.1\mu F$ ,  $T_j=0^{\circ}C$  to  $125^{\circ}C$

CHARACTERISTIC	SYMBOL	TEST CONDITION		MIN.	TYP.	MAX.	UNIT
Output Voltage	$V_{out}$	$T_j=25^{\circ}C$		8.55	9.0	9.45	V
Input Regulation	Reg line	$T_j=25^{\circ}C$	$11.4V \leq V_{in} \leq 24V$ ,	-	80	200	mV
			$12V \leq V_{in} \leq 24V$ ,	-	20	160	
Load Regulation	Reg load	$T_j=25^{\circ}C$	$1.0mA \leq I_{out} \leq 100mA$	-	17	90	mV
			$1.0mA \leq I_{out} \leq 40mA$	-	8.0	45	
Output Voltage	$V_{out}$	$11.4V \leq V_{in} \leq 24V$ , $1.0mA \leq I_{out} \leq 40mA$		8.37	-	9.63	V
		$V_{in}=15V$ , $1.0mA \leq I_{out} \leq 70mA$		8.37	-	9.63	
Quiescent Current	$I_Q$	$T_j=25^{\circ}C$		-	3.2	6.5	mA
		$T_j=125^{\circ}C$		-	-	6.0	
Quiescent Current Change	$\Delta I_Q$	$12V \leq V_{in} \leq 24V$ ,		-	-	1.5	mA
		$1.0mA \leq I_{out} \leq 40mA$		-	-	0.1	
Output Noise Voltage	$V_{NO}$	$T_a=25^{\circ}C$ , $10Hz \leq f \leq 100kHz$		-	65	-	$\mu V_{rms}$
Long Term Stability	$\Delta V_{out}/\Delta t$			-	21	-	mV/1.0kHrs
Ripple Rejection Ratio	RR	$F=120Hz$ , $12V \leq V_{in} \leq 24V$ , $T_j=25^{\circ}C$		36	44	-	dB
Dropout Voltage	$ V_{in}-V_{out} $	$T_j=25^{\circ}C$			1.7		V
Average Temperature Coefficient of Output Voltage	$TC_{vo}$	$I_{out}=5mA$			0.85	-	$mV/^{\circ}C$

**THREE TERMINAL POSITIVE VOLTAGE REGULATORS**      **三端穩壓器 FH78LXX**

**ELECTRICAL CHARACTERISTICS**

**FH78L10**

Unless otherwise specified,  $V_{in}=16V$ ,  $I_{out}=40mA$ ,  $C_{in}=0.33\mu F$ ,  $C_{out}=0.1\mu F$ ,  $T_j=0^{\circ}C$  to  $125^{\circ}C$

CHARACTERISTIC	SYMBOL	TEST CONDITION		MIN.	TYP.	MAX.	UNIT
Output Voltage	$V_{out}$	$T_j=25^{\circ}C$		9.5	10	10.5	V
Input Regulation	Reg line	$T_j=25^{\circ}C$	$12.5V \leq V_{in} \leq 25V$ ,	-	80	230	mV
			$13V \leq V_{in} \leq 25V$ ,	-	30	170	
Load Regulation	Reg load	$T_j=25^{\circ}C$	$1.0mA \leq I_{out} \leq 100mA$	-	18	90	mV
			$1.0mA \leq I_{out} \leq 40mA$	-	8.5	45	
Output Voltage	$V_{out}$	$12.5V \leq V_{in} \leq 25V$ , $1.0mA \leq I_{out} \leq 40mA$		9.3	-	10.7	V
		$V_{in}=16V$ , $1.0mA \leq I_{out} \leq 70mA$		9.3	-	10.7	
Quiescent Current	$I_Q$	$T_j=25^{\circ}C$		-	3.2	6.5	mA
		$T_j=125^{\circ}C$		-	-	6.0	
Quiescent Current Change	$\Delta I_Q$	$13V \leq V_{in} \leq 25V$ ,		-	-	1.5	mA
		$1.0mA \leq I_{out} \leq 40mA$		-	-	0.1	
Output Noise Voltage	$V_{NO}$	$T_a=25^{\circ}C$ , $10Hz \leq f \leq 100kHz$		-	70	-	$\mu V_{rms}$
Long Term Stability	$\Delta V_{out}/\Delta t$			-	22	-	mV/1.0kHrs
Ripple Rejection Ratio	RR	$F=120Hz$ , $13V \leq V_{in} \leq 24V$ , $T_j=25^{\circ}C$		37	43	-	dB
Dropout Voltage	$ V_{in}-V_{out} $	$T_j=25^{\circ}C$			1.7		V
Average Temperature Coefficient of Output Voltage	$TC_{vo}$	$I_{out}=5mA$		-	-0.9	-	$mV/^{\circ}C$



**THREE TERMINAL POSITIVE VOLTAGE REGULATORS**      **三端穩壓器 FH78LXX**

**ELECTRICAL CHARACTERISTICS**

**FH78L12**

Unless otherwise specified,  $V_{in}=19V$ ,  $I_{out}=40mA$ ,  $C_{in}=0.33\mu F$ ,  $C_{out}=0.1\mu F$ ,  $T_j=0^{\circ}C$  to  $125^{\circ}C$

CHARACTERISTIC	SYMBOL	TEST CONDITION		MIN.	TYP.	MAX.	UNIT
Output Voltage	$V_{out}$	$T_j=25^{\circ}C$		11.4	12	12.6	V
Input Regulation	Reg line	$T_j=25^{\circ}C$	$14.5V \leq V_{in} \leq 27V$ ,	-	120	250	mV
			$16V \leq V_{in} \leq 27V$ ,	-	100	200	
Load Regulation	Reg load	$T_j=25^{\circ}C$	$1.0mA \leq I_{out} \leq 100mA$	-	20	100	mV
			$1.0mA \leq I_{out} \leq 40mA$	-	10	50	
Output Voltage	$V_{out}$	$14.5V \leq V_{in} \leq 27V$ , $1.0mA \leq I_{out} \leq 40mA$		11.16	-	12.84	V
		$V_{in}=19V$ , $1.0mA \leq I_{out} \leq 70mA$		11.16	-	12.84	
Quiescent Current	$I_Q$	$T_j=25^{\circ}C$		-	3.2	6.5	mA
		$T_j=125^{\circ}C$		-	-	6.0	
Quiescent Current Change	$\Delta I_Q$	$16V \leq V_{in} \leq 27V$ ,		-	-	1.5	mA
		$1.0mA \leq I_{out} \leq 40mA$		-	-	0.1	
Output Noise Voltage	$V_{NO}$	$T_a=25^{\circ}C$ , $10Hz \leq f \leq 100kHz$		-	80	-	$\mu V_{rms}$
Long Term Stability	$\Delta V_{out}/\Delta t$			-	24	-	mV/1.0kHrs
Ripple Rejection Ratio	RR	$F=120Hz$ , $15V \leq V_{in} \leq 25V$ , $T_j=25^{\circ}C$		36	41	-	dB
Dropout Voltage	$ V_{in}-V_{out} $	$T_j=25^{\circ}C$			1.7		V
Average Temperature Coefficient of Output Voltage	$TC_{vo}$	$I_{out}=5mA$		-	-1.0	-	$mV/^{\circ}C$

**THREE TERMINAL POSITIVE VOLTAGE REGULATORS**      **三端穩壓器 FH78LXX**

**ELECTRICAL CHARACTERISTICS**

**FH78L15**

Unless otherwise specified,  $V_{in}=23V$ ,  $I_{out}=40mA$ ,  $C_{in}=0.33\mu F$ ,  $C_{out}=0.1\mu F$ ,  $T_j=0^{\circ}C$  to  $125^{\circ}C$

CHARACTERISTIC	SYMBOL	TEST CONDITION		MIN.	TYP.	MAX.	UNIT
Output Voltage	$V_{out}$	$T_j=25^{\circ}C$		14.25	15	15.75	V
Input Regulation	Reg line	$T_j=25^{\circ}C$	$17.5V \leq V_{in} \leq 30V$ ,	-	130	300	mV
			$20V \leq V_{in} \leq 30V$ ,	-	110	250	
Load Regulation	Reg load	$T_j=25^{\circ}C$	$1.0mA \leq I_{out} \leq 100mA$	-	25	150	mV
			$1.0mA \leq I_{out} \leq 40mA$	-	12	75	
Output Voltage	$V_{out}$	$17.5V \leq V_{in} \leq 30V$ , $1.0mA \leq I_{out} \leq 40mA$		13.95	-	16.05	V
		$V_{in}=23V$ , $1.0mA \leq I_{out} \leq 70mA$		13.95	-	16.05	
Quiescent Current	$I_Q$	$T_j=25^{\circ}C$		-	3.3	6.5	mA
		$T_j=125^{\circ}C$		-	-	6.0	
Quiescent Current Change	$\Delta I_Q$	$20V \leq V_{in} \leq 30V$ ,		-	-	1.5	mA
		$1.0mA \leq I_{out} \leq 40mA$		-	-	0.1	
Output Noise Voltage	$V_{NO}$	$T_a=25^{\circ}C$ , $10Hz \leq f \leq 100kHz$		-	90	-	$\mu V_{rms}$
Long Term Stability	$\Delta V_{out}/\Delta t$			-	30	-	mV/1.0kHrs
Ripple Rejection Ratio	RR	$F=120Hz$ , $18.5V \leq V_{in} \leq 28.5V$ , $T_j=25^{\circ}C$		34	40	-	dB
Dropout Voltage	$ V_{in}-V_{out} $	$T_j=25^{\circ}C$			1.7		V
Average Temperature Coefficient of Output Voltage	$TC_{vo}$	$I_{out}=5mA$		-	-1.3	-	$mV/^{\circ}C$

**THREE TERMINAL POSITIVE VOLTAGE REGULATORS**      **三端穩壓器 FH78LXX**

**ELECTRICAL CHARACTERISTICS**

**FH78L18**

Unless otherwise specified,  $V_{in}=27V$ ,  $I_{out}=40mA$ ,  $C_{in}=0.33\mu F$ ,  $C_{out}=0.1\mu F$ ,  $T_j=0^{\circ}C$  to  $125^{\circ}C$

CHARACTERISTIC	SYMBOL	TEST CONDITION		MIN.	TYP.	MAX.	UNIT
Output Voltage	$V_{out}$	$T_j=25^{\circ}C$		17.1	18	18.9	V
Input Regulation	Reg line	$T_j=25^{\circ}C$	$21.4V \leq V_{in} \leq 33V$ ,	-	32	325	mV
			$22V \leq V_{in} \leq 33V$ ,	-	27	275	
Load Regulation	Reg load	$T_j=25^{\circ}C$	$1.0mA \leq I_{out} \leq 100mA$	-	30	170	mV
			$1.0mA \leq I_{out} \leq 40mA$	-	15	75	
Output Voltage	$V_{out}$	$21.4V \leq V_{in} \leq 33V$ , $1.0mA \leq I_{out} \leq 40mA$		16.74	-	19.26	V
		$V_{in}=27V$ , $1.0mA \leq I_{out} \leq 70mA$		16.74	-	19.26	
Quiescent Current	$I_Q$	$T_j=25^{\circ}C$		-	3.3	6.5	mA
		$T_j=125^{\circ}C$		-	-	6.0	
Quiescent Current Change	$\Delta I_Q$	$22V \leq V_{in} \leq 33V$ ,		-	-	1.5	mA
		$1.0mA \leq I_{out} \leq 40mA$		-	-	0.1	
Output Noise Voltage	$V_{NO}$	$T_a=25^{\circ}C$ , $10Hz \leq f \leq 100kHz$		-	150	-	$\mu V_{rms}$
Long Term Stability	$\Delta V_{out}/\Delta t$			-	45	-	mV/1.0kHrs
Ripple Rejection Ratio	RR	$F=120Hz$ , $23V \leq V_{in} \leq 33V$ , $T_j=25^{\circ}C$		32	38	-	dB
Dropout Voltage	$ V_{in}-V_{out} $	$T_j=25^{\circ}C$			1.7		V
Average Temperature Coefficient of Output Voltage	$TC_{vo}$	$I_{out}=5mA$		-	-1.5	-	$mV/^{\circ}C$

**THREE TERMINAL POSITIVE VOLTAGE REGULATORS**      **三端穩壓器 FH78LXX**

**ELECTRICAL CHARACTERISTICS**

**FH78L20**

Unless otherwise specified,  $V_{in}=29V$ ,  $I_{out}=40mA$ ,  $C_{in}=0.33\mu F$ ,  $C_{out}=0.1\mu F$ ,  $T_j=0^{\circ}C$  to  $125^{\circ}C$

CHARACTERISTIC	SYMBOL	TEST CONDITION		MIN.	TYP.	MAX.	UNIT
Output Voltage	$V_{out}$	$T_j=25^{\circ}C$		19.0	20	21.0	V
Input Regulation	Reg line	$T_j=25^{\circ}C$	$23.5V \leq V_{in} \leq 35V$ ,	-	33	330	mV
			$24V \leq V_{in} \leq 35V$ ,	-	28	285	
Load Regulation	Reg load	$T_j=25^{\circ}C$	$1.0mA \leq I_{out} \leq 100mA$	-	33	180	mV
			$1.0mA \leq I_{out} \leq 40mA$	-	17	90	
Output Voltage	$V_{out}$	$23.5V \leq V_{in} \leq 35V$ , $1.0mA \leq I_{out} \leq 40mA$		18.6	-	21.4	V
		$V_{in}=29V$ , $1.0mA \leq I_{out} \leq 70mA$		18.6	-	21.4	
Quiescent Current	$I_Q$	$T_j=25^{\circ}C$		-	3.3	6.5	mA
		$T_j=125^{\circ}C$		-	-	6.0	
Quiescent Current Change	$\Delta I_Q$	$24V \leq V_{in} \leq 35V$ ,		-	-	1.5	mA
		$1.0mA \leq I_{out} \leq 40mA$		-	-	0.1	
Output Noise Voltage	$V_{NO}$	$T_a=25^{\circ}C$ , $10Hz \leq f \leq 100kHz$		-	170	-	$\mu V_{rms}$
Long Term Stability	$\Delta V_{out}/\Delta t$			-	49	-	mV/1.0kHrs
Ripple Rejection Ratio	RR	$F=120Hz$ , $25V \leq V_{in} \leq 35V$ , $T_j=25^{\circ}C$		31	37	-	dB
Dropout Voltage	$ V_{in}-V_{out} $	$T_j=25^{\circ}C$			1.7		V
Average Temperature Coefficient of Output Voltage	$TC_{vo}$	$I_{out}=5mA$		-	-1.7	-	$mV/^{\circ}C$

**THREE TERMINAL POSITIVE VOLTAGE REGULATORS**      **三端穩壓器 FH78LXX**

**ELECTRICAL CHARACTERISTICS**

**FH78L24**

Unless otherwise specified,  $V_{in}=33V$ ,  $I_{out}=40mA$ ,  $C_{in}=0.33\mu F$ ,  $C_{out}=0.1\mu F$ ,  $T_j=0^{\circ}C$  to  $125^{\circ}C$

CHARACTERISTIC	SYMBOL	TEST CONDITION		MIN.	TYP.	MAX.	UNIT
Output Voltage	$V_{out}$	$T_j=25^{\circ}C$		22.8	24	25.2	V
Input Regulation	Reg line	$T_j=25^{\circ}C$	$27.5V \leq V_{in} \leq 38V$ ,	-	35	350	mV
			$28V \leq V_{in} \leq 38V$ ,	-	30	300	
Load Regulation	Reg load	$T_j=25^{\circ}C$	$1.0mA \leq I_{out} \leq 100mA$	-	40	200	mV
			$1.0mA \leq I_{out} \leq 40mA$	-	20	100	
Output Voltage	$V_{out}$	$27.5V \leq V_{in} \leq 38V$ , $1.0mA \leq I_{out} \leq 40mA$		22.32	-	25.68	V
		$V_{in}=33V$ , $1.0mA \leq I_{out} \leq 70mA$		22.32	-	25.68	
Quiescent Current	$I_Q$	$T_j=25^{\circ}C$		-	3.5	6.5	mA
		$T_j=125^{\circ}C$		-	-	6.0	
Quiescent Current Change	$\Delta I_Q$	$28V \leq V_{in} \leq 38V$ ,		-	-	1.5	mA
		$1.0mA \leq I_{out} \leq 40mA$		-	-	0.1	
Output Noise Voltage	$V_{NO}$	$T_a=25^{\circ}C$ , $10Hz \leq f \leq 100kHz$		-	200	-	$\mu V_{rms}$
Long Term Stability	$\Delta V_{out}/\Delta t$			-	56	-	mV/1.0kHrs
Ripple Rejection Ratio	RR	$F=120Hz$ , $29V \leq V_{in} \leq 39V$ , $T_j=25^{\circ}C$		31	35	-	dB
Dropout Voltage	$ V_{in}-V_{out} $	$T_j=25^{\circ}C$			1.7		V
Average Temperature Coefficient of Output Voltage	$TC_{vo}$	$I_{out}=5mA$		-	-2.0	-	$mV/^{\circ}C$