

1 Watt Zener Diode • 5% Tolerance • Case B*

TYPE NO.	CENTRAL TYPE NO.	Zener Voltage Vz @ Iz	Test Current Iz	Zener Impedance Zz	TYPE NO.	CENTRAL TYPE NO.	Zener Voltage Vz @ Iz	Test Current Iz	Zener Impedance Zz
		Volts	mA	Ohms			Volts	mA	Ohms
1N4728A	C1Z3.3B	3.3	76	10	1N4750A	C1Z27B	27	9.5	35
1N4729A	C1Z3.6B	3.6	69	10	1N4751A	C1Z30B	30	8.5	40
1N4730A	C1Z3.9B	3.9	64	9.0	1N4752A	C1Z33B	33	7.5	45
1N4731A	C1Z4.3B	4.3	58	9.0	1N4753A	C1Z36B	36	7.0	50
1N5732A	C1Z4.7B	4.7	53	8.0	1N4754A	C1Z39B	39	6.5	60
1N4733A	C1Z5.1B	5.1	49	7.0	1N4755A	C1Z43B	43	6.0	70
1N4734A	C1Z5.6B	5.6	45	5.0	1N4756A	C1Z47B	47	5.5	80
1N4735A	C1Z6.2B	6.2	41	2.0	1N4757A	C1Z51B	51	5.0	95
1N4736A	C1Z6.8B	6.8	37	3.5	1N4758A	C1Z56B	56	4.5	110
1N4737A	C1Z7.5B	7.5	34	4.0	1N4759A	C1Z62B	62	4.0	125
1N4738A	C1Z8.2B	8.2	31	4.5	1N4760A	C1Z68B	68	3.7	150
1N4739A	C1Z9.1B	9.1	28	5.0	1N4761A	C1Z75B	75	3.3	175
1N4740A	C1Z10B	10	25	7.0	1N4762A	C1Z82B	82	3.0	200
1N4741A	C1Z11B	11	23	8.0	1N4763A	C1Z91B	91	2.8	250
1N4742A	C1Z12B	12	21	9.0	1N4764A	C1Z100B	100	2.5	350
1N4743A	C1Z13B	13	19	10		C1Z110B	110	2.3	450
1N4744A	C1Z15B	15	17	14		C1Z120B	120	2.0	550
1N4745A	C1Z16B	16	15.5	16		C1Z130B	130	1.9	700
1N4746A	C1Z18B	18	14	20		C1Z150B	150	1.7	1000
1N4747A	C1Z20B	20	12.5	22		C1Z160B	160	1.6	1100
1N4748A	C1Z22B	22	11.5	23		C1Z180B	180	1.4	1200
1N4749A	C1Z24B	24	10.5	25		C1Z200B	200	1.2	1500

2 Watt Zener Diode • 5% Tolerance • Case B

CENTRAL TYPE NO.	Zener Voltage Vz @ Iz	Test Current Iz	Zener Impedance Zz	Maximum Zener Current IzM	CENTRAL TYPE NO.	Zener Voltage Vz @ Iz	Test Current Iz	Zener Impedance Zz	Maximum Zener Current IzM
	Volts	mA	Ohms	mA		Volts	mA	Ohms	mA
C2Z6.2B	6.2	60	2.0	215	C2Z45B	45	8.5	76	27
C2Z6.8B	6.8	55	3.5	195	C2Z47B	47	8.0	80	26
C2Z7.5B	7.5	50	4.0	175	C2Z50B	50	7.6	93	25
C2Z8.2B	8.2	46	4.5	155	C2Z51B	51	7.4	95	24
C2Z9.1B	9.1	41	5.0	140	C2Z52B	52	7.3	97	23
C2Z10B	10	37	7.0	125	C2Z56B	56	6.7	110	22
C2Z11B	11	34	8.0	115	C2Z62B	62	6.0	125	20
C2Z12B	12	31	9.0	105	C2Z68B	68	5.5	150	18
C2Z13B	13	30	10	98	C2Z75B	75	5.0	175	16
C2Z14B	14	29	12	92	C2Z82B	82	4.5	200	14
C2Z15B	15	25	14	85	C2Z91B	91	4.2	250	13
C2Z16B	16	23	16	80	C2Z100B	100	3.7	350	12
C2Z17B	17	22	18	75	C2Z105B	105	3.6	400	11
C2Z18B	18	21	20	70	C2Z110B	110	3.4	450	10
C2Z19B	19	20	21	66	C2Z120B	120	3.0	550	9
C2Z20B	20	19	22	62	C2Z130B	130	2.8	700	8
C2Z22B	22	17	23	56	C2Z140B	140	2.7	850	7.5
C2Z24B	24	16	25	51	C2Z150B	150	2.5	1000	7
C2Z25B	25	15.3	28	49	C2Z160B	160	2.4	1110	6.5
C2Z27B	27	14	35	46	C2Z180B	180	2.1	1200	6
C2Z30B	30	12	40	41	C2Z200B	200	1.8	1500	5.5
C2Z33B	33	11	45	38					
C2Z36B	36	10	50	35					
C2Z39B	39	10	60	31					
C2Z43B	43	9	70	28					

*1 Watt Zener Diode Available in Either Glass or Epoxy Case.

CASE OUTLINE DRAWINGS

D

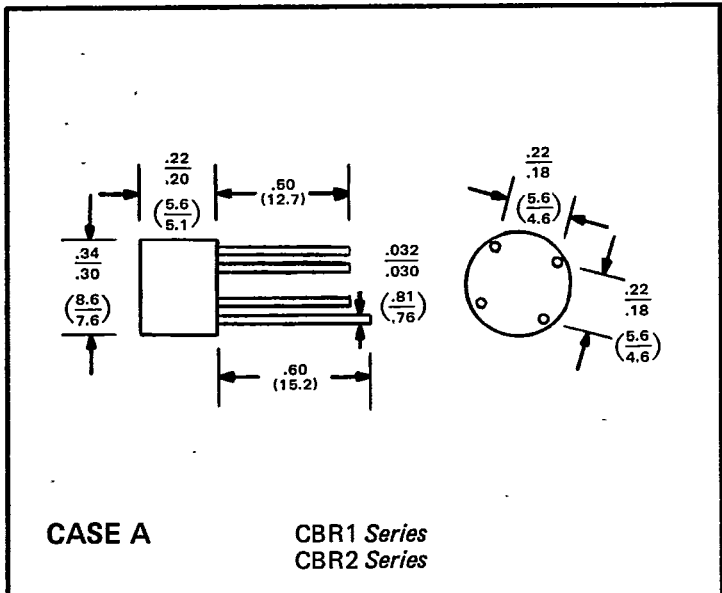

CASE A

CBR1 Series
CBR2 Series

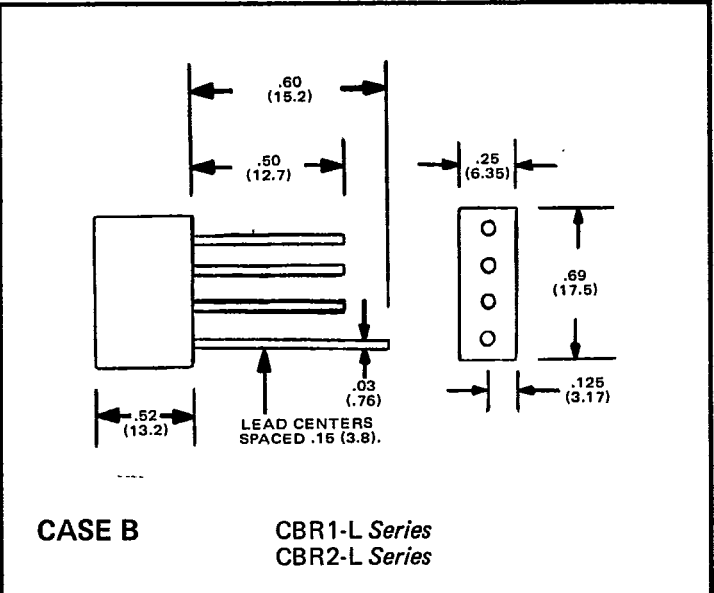

CASE B

CBR1-L Series
CBR2-L Series

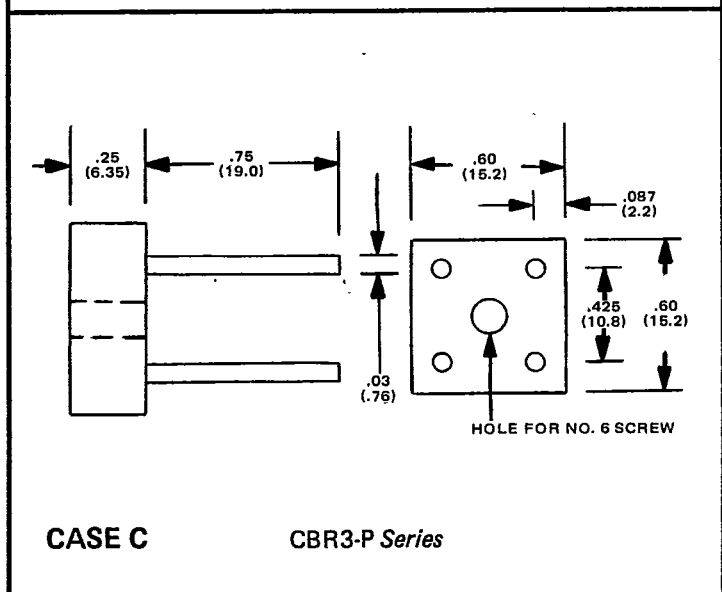

CASE C

CBR3-P Series

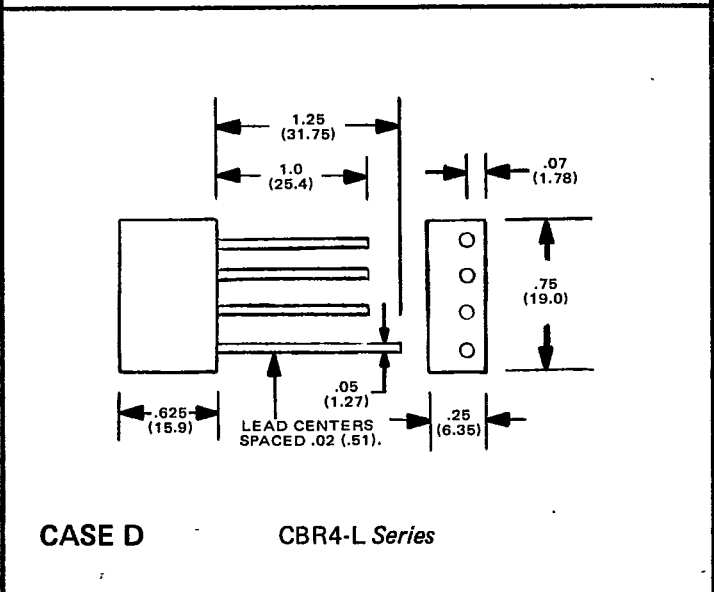

CASE D

CBR4-L Series

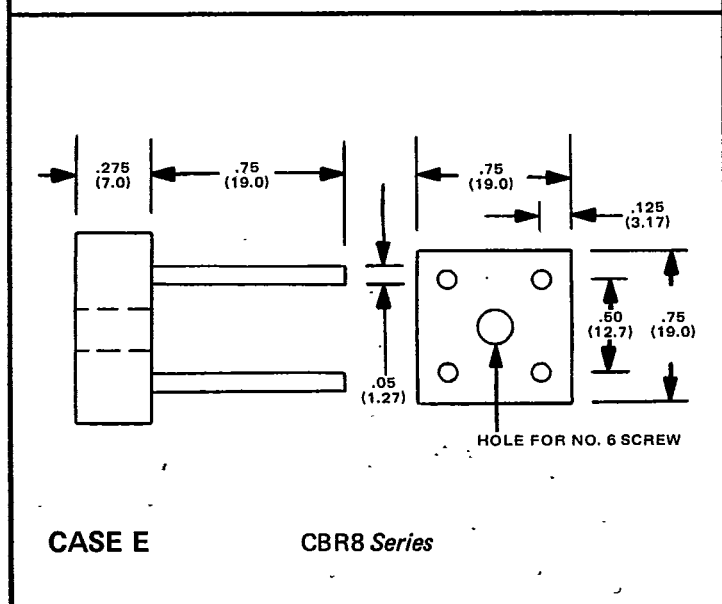

CASE E

CBR8 Series

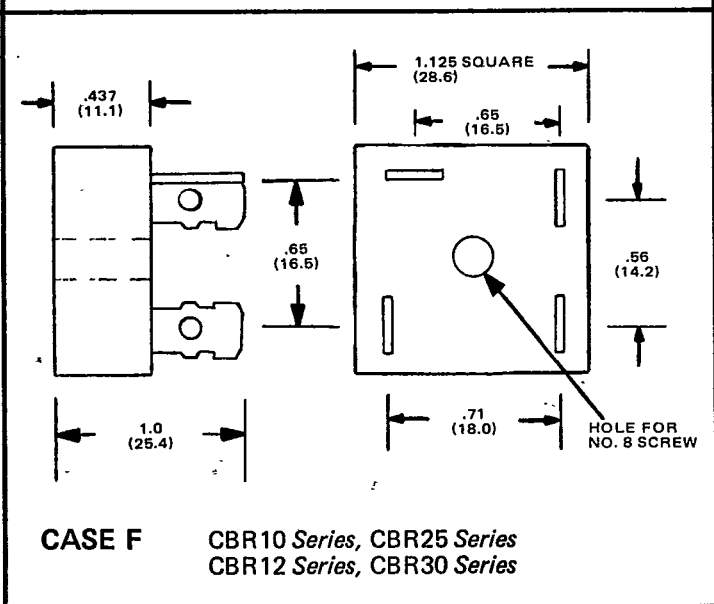

CASE F

CBR10 Series, CBR25 Series
CBR12 Series, CBR30 Series

All Dimensions in Inches (Millimeters)

Drawings Not To Scale

f

MECHANICAL OUTLINE DRAWINGS

D

TO-5

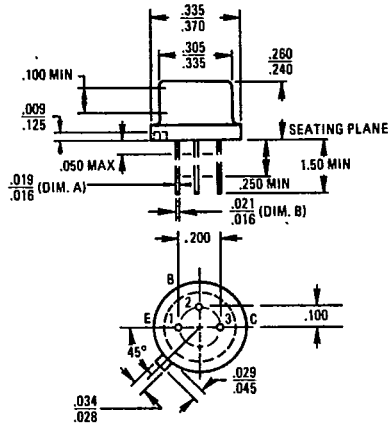

TO-18

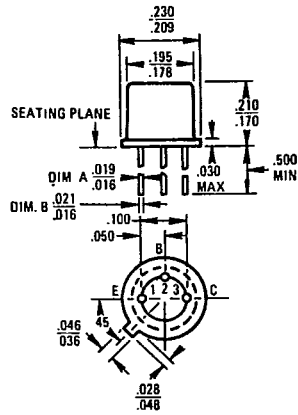

TO-39

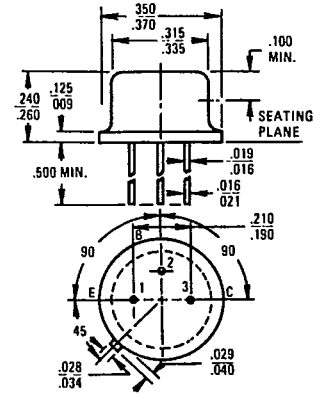

TO-46

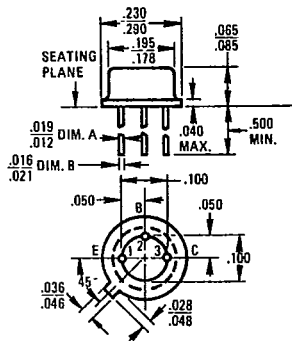

TO-72

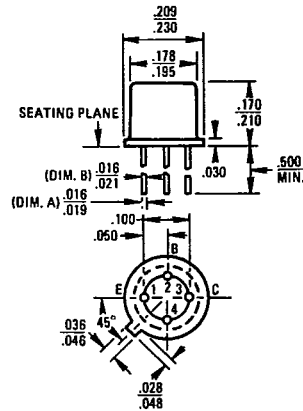

TO-92

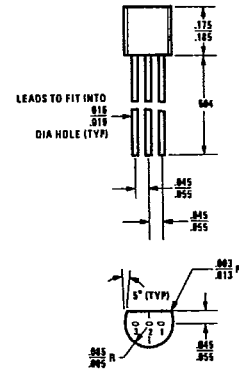

TO-98

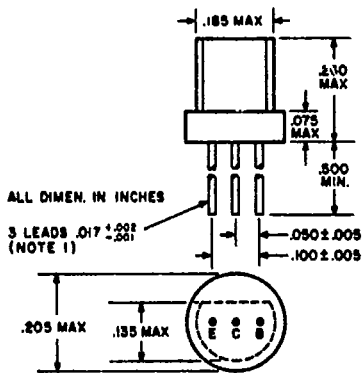

TO-105

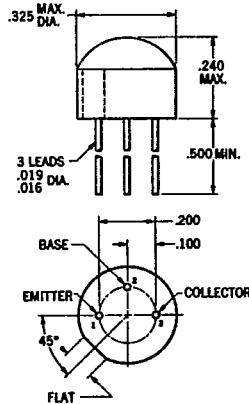

TO-106

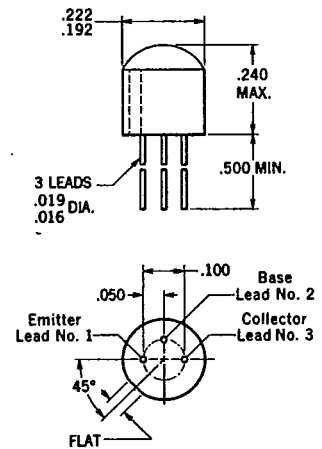

74

OUTLINE DRAWINGS FOR CENTRAL SEMICONDUCTOR ZENER DIODES

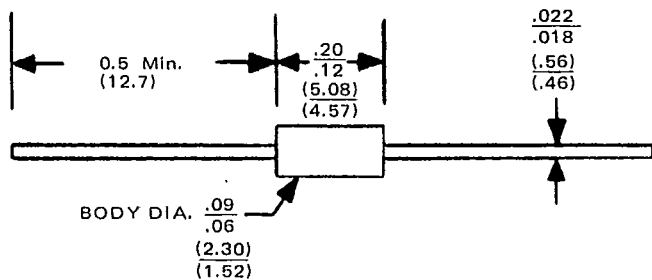

CASE A (Do-35)

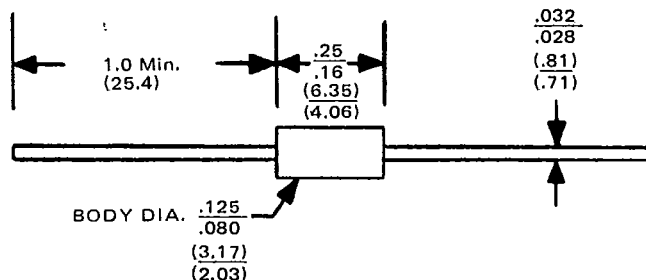

CASE B

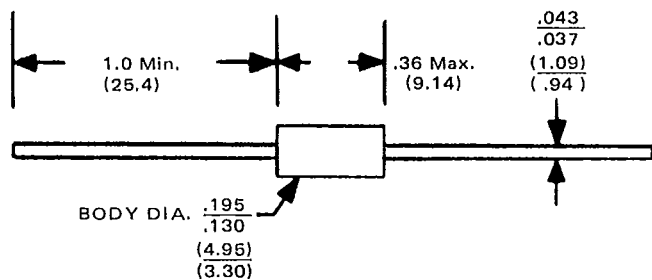

CASE C

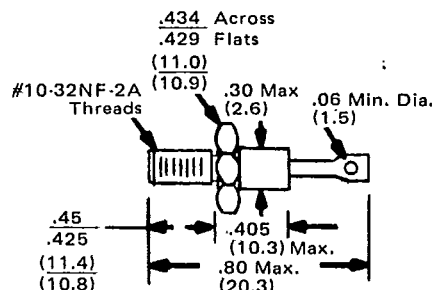

CASE D (Do-4)

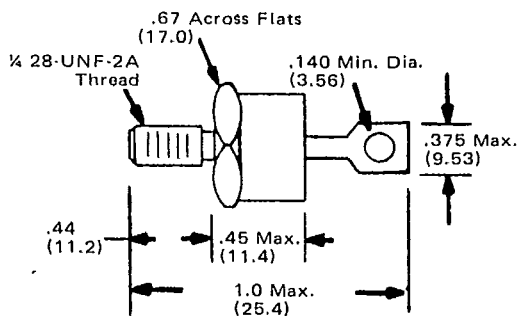

CASE E (Do-5)

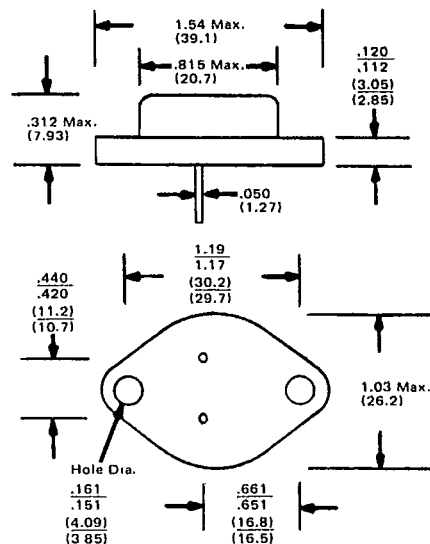

CASE F (To-3)

ALL DIMENSIONS IN INCHES (MILLIMETERS)

DRAWINGS NOT TO SCALE