

# SN75LBC187 MULTICHANNEL EIA-232 DRIVER/RECEIVER WITH CHARGE PUMP

SLLS130C – SEPTEMBER 1991 – REVISED MAY 1995

- **Single IC and Single 5-V Supply Interface for Serial Communication Ports**
- **Meets or Exceeds the Requirements of ANSI Standards EIA/TIA-232-E-1991, EIA/TIA-562, and ITU Recommendation V.28**
- **Switched-Capacitor Voltage Converter Eliminates Need for  $\pm 12$ -V Supplies**
- **Voltage Converter Operates With Low Capacitance . . . 0.1  $\mu$ F Min**
- **Designed for Data Rates up to 120 kb/s Over 3-m Cable**
- **Available in Shrink Small-Outline 25-mil-Pitch Package**
- **Shutdown Mode to Save Power When Not in Use**
- **$\pm 30$ -V Receiver Input Voltage Range**
- **LinBiCMOS™ Process Technology**
- **Applications**
  - Laptop or Notebook Computers
  - Portable Terminals
  - Single-Board Computers
  - Portable Test Equipment

**DB PACKAGE  
(TOP VIEW)**

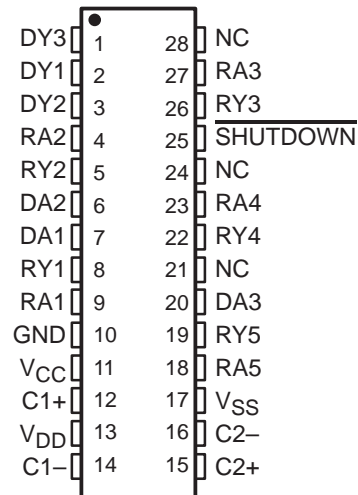

NC—No internal connection

## description

The SN75LBC187 is a low-power LinBiCMOS™ device containing three drivers, five receivers, and a switched-capacitor voltage converter. The SN75LBC187 provides a single chip and single 5-V supply interface between the asynchronous communications element and the serial port connector of the data terminal equipment (DTE). This device has been designed to conform to ANSI Standards EIA/TIA-232-E, EIA/TIA-562, and ITU recommendation V.28.

The switched-capacitor voltage converter of the SN75LBC187 uses four small external capacitors to generate the positive and negative voltages required by EIA/TIA-232-E (and V.28) line drivers from a single 5-V input. The drivers feature output slew-rate limiting to eliminate the need for external filter capacitors. The receivers can accept  $\pm 30$  V without damage. The device also features a reduced power or shutdown mode that cuts the quiescent power to the IC when not transmitting data between the CPU and peripheral.

The SN75LBC187 has been designed using LinBiCMOS™ technology and cells contained in the Texas Instruments LinASIC™ library. The SN75LBC187 is characterized for operation from 0°C to 70°C.

### NOTE:

This device includes circuit designs and process technologies that have patents pending.



Please be aware that an important notice concerning availability, standard warranty, and use in critical applications of Texas Instruments semiconductor products and disclaimers thereto appears at the end of this data sheet.

LinBiCMOS and LinASIC are a trademarks of Texas Instruments Incorporated.

PRODUCTION DATA information is current as of publication date. Products conform to specifications per the terms of Texas Instruments standard warranty. Production processing does not necessarily include testing of all parameters.



POST OFFICE BOX 655303 • DALLAS, TEXAS 75265

Copyright © 1995, Texas Instruments Incorporated

# SN75LBC187 MULTICHANNEL EIA-232 DRIVER/RECEIVER WITH CHARGE PUMP

SLLS130C – SEPTEMBER 1991 – REVISED MAY 1995

## logic symbol†

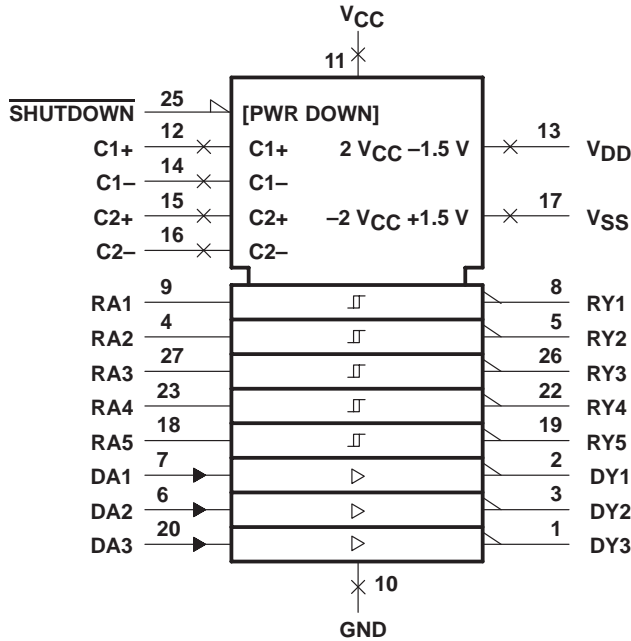

## logic diagram (positive logic)

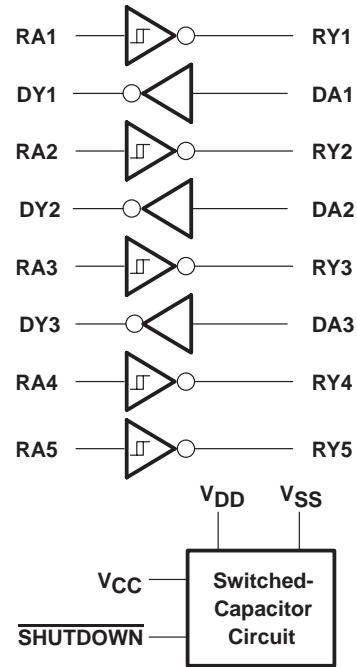

† This symbol is in accordance with ANSI/IEEE Std. 91-1984 and IEC Publication 617-12.

## absolute maximum ratings over operating free-air temperature range (unless otherwise noted)‡

Supply voltage range, V <sub>CC</sub> (see Note 1)	0.3 V to 6 V
Positive output supply voltage range, V <sub>DD</sub>	V <sub>CC</sub> - 0.3 V to 15 V
Negative output supply voltage range, V <sub>SS</sub>	0.3 V to -15 V
Input voltage range, V <sub>I</sub> : RA	±30 V
All other inputs	-0.3 V to V <sub>CC</sub> + 3 V
Output voltage range, V <sub>O</sub> : DY	-2 V <sub>CC</sub> + 1.2 V to 2 V <sub>CC</sub> - 1.2 V
All other outputs	-0.3 V to V <sub>CC</sub> + 3 V
Continuous total power dissipation	See Dissipation Rating Table
Operating free-air temperature range, T <sub>A</sub>	0°C to 70°C
Storage temperature range, T <sub>stg</sub>	-65°C to 150°C
Lead temperature 1,6 mm (1/16 inch) from case for 10 seconds	260°C

‡ Stresses beyond those listed under "absolute maximum ratings" may cause permanent damage to the device. These are stress ratings only, and functional operation of the device at these or any other conditions beyond those indicated under "recommended operating conditions" is not implied. Exposure to absolute-maximum-rated conditions for extended periods may affect device reliability.

NOTE 1: All voltages are with respect to the network ground terminal.

DISSIPATION RATING TABLE

PACKAGE	T <sub>A</sub> ≤ 25°C POWER RATING	DERATING FACTOR ABOVE T <sub>A</sub> = 25°C	T <sub>A</sub> = 70°C POWER RATING
DB	1025 mW	8.2 mW/°C	656 mW



POST OFFICE BOX 655303 • DALLAS, TEXAS 75265

**SN75LBC187**  
**MULTICHANNEL EIA-232 DRIVER/RECEIVER**  
**WITH CHARGE PUMP**

SLLS130C – SEPTEMBER 1991 – REVISED MAY 1995

**recommended operating conditions**

		MIN	NOM	MAX	UNIT	
Supply voltage, $V_{CC}$		4.5	5	5.5	V	
High-level input voltage, $V_{IH}$	DA	2			V	
	RA, <u>SHUTDOWN</u>	2.4				
Low-level input voltage, $V_{IL}$	RA, DA, <u>SHUTDOWN</u>	0.8			V	
Receiver input voltage, $V_I$		-25			25	V
High-level output current, $I_{OH}$	RY				-1	mA
Low-level output current, $I_{OL}$	RY				3.2	mA
Output current, $I_O$	$V_{DD}$				$\pm 10$	$\mu A$
	$V_{SS}$				$\pm 10$	$\mu A$
C1, C2, C3, C4 charge pump capacitors		0.1	0.47		$\mu F$	
Operating free-air temperature, $T_A$		0			70	$^{\circ}C$

**electrical characteristics over recommended operating conditions (unless otherwise noted)**

PARAMETER		TEST CONDITIONS		MIN	TYP†	MAX	UNIT	
$V_{OH}$	High-level output voltage	Receiver	$I_O = -1$ mA	3.5			V	
		Driver	$R_L = 3$ k $\Omega$ to GND	5	7			
$V_{OL}$	Low-level output voltage	Receiver	$I_O = 3.2$ mA	0.4			V	
		Driver	$R_L = 3$ k $\Omega$ to GND		-7	-5		
$V_{IT+}$	Receiver positive-going input voltage threshold				1.7	2.4	V	
$V_{IT-}$	Receiver negative-going input voltage threshold			0.8	1.2		V	
$V_{hys}$	Receiver input hysteresis voltage ( $V_{IT+} - V_{IT-}$ )				0.5	1	V	
$r_i$	Receiver input resistance	$V_{CC} = 5$ V, $T_A = 25^{\circ}C$		3	5	7	k $\Omega$	
$r_o$	Driver output resistance	$V_{CC} = 0$ , $V_O = \pm 2$ V		300			$\Omega$	
$I_I$	Input current (DA, <u>SHUTDOWN</u> )	$V_I = 0$ to $V_{CC}$					$\pm 50$	$\mu A$
$I_{OS}$	Driver output short-circuit current	$V_O = 0$		$\pm 10$			mA	
$I_{CC}$	Supply current	Normal operation	All outputs open, <u>SHUTDOWN</u> at 2.4 V	15			30	mA
		Shutdown mode	All outputs open, <u>SHUTDOWN</u> at 0.1 V				10	$\mu A$

† All typical values are at  $V_{CC} = 5$  V and  $T_A = 25^{\circ}C$ .

**SN75LBC187**  
**MULTICHANNEL EIA-232 DRIVER/RECEIVER**  
**WITH CHARGE PUMP**

SLLS130C – SEPTEMBER 1991 – REVISED MAY 1995

**switching characteristics over recommended operating conditions,  $T_A = 25^\circ\text{C}$  (unless otherwise noted)**

PARAMETER		TEST CONDITIONS		MIN	MAX	UNIT
t <sub>PLH</sub>	Propagation delay time, low- to high-level output	Receiver	R <sub>L</sub> = 5 kΩ, See Figure 1	C <sub>L</sub> = 50 pF,	1.25	μs
		Driver	R <sub>L</sub> = 3 kΩ, See Figure 2	C <sub>L</sub> = 1200 pF,	1.25	μs
t <sub>PHL</sub>	Propagation delay time, high- to low-level output	Receiver	R <sub>L</sub> = 5 kΩ, See Figure 1	C <sub>L</sub> = 50 pF,	1.25	μs
		Driver	R <sub>L</sub> = 3 kΩ, See Figure 2	C <sub>L</sub> = 1200 pF,	1.25	μs
t <sub>r</sub>	Rise time, driver output		R <sub>L</sub> = 3 kΩ, V <sub>O</sub> = -3 V to 3 V,	C <sub>L</sub> = 50 pF, See Note 2	200	ns
			R <sub>L</sub> = 3 kΩ, V <sub>O</sub> = -3.3 V to 3.3 V,	C <sub>L</sub> = 2500 pF, See Note 3	1.5	μs
t <sub>f</sub>	Fall time, driver output		R <sub>L</sub> = 3 kΩ, V <sub>O</sub> = 3 V to -3 V	C <sub>L</sub> = 50 pF,	200	ns
			R <sub>L</sub> = 3 kΩ, V <sub>O</sub> = 3.3 V to -3.3 V	C <sub>L</sub> = 2500 pF,	1.5	μs

- NOTES: 2. The 200 ns for the output to change from -3 V to 3 V (or vice versa) corresponds to the 30 V/μs maximum slew rate of EIA/TIA-232-E, EIA/TIA-562, and ITU Recommendation V.28.
3. The more stringent requirement for transition times comes from the EIA/TIA-562, which requires the rise and fall times to be measured from 3.3 V.



PARAMETER MEASUREMENT INFORMATION

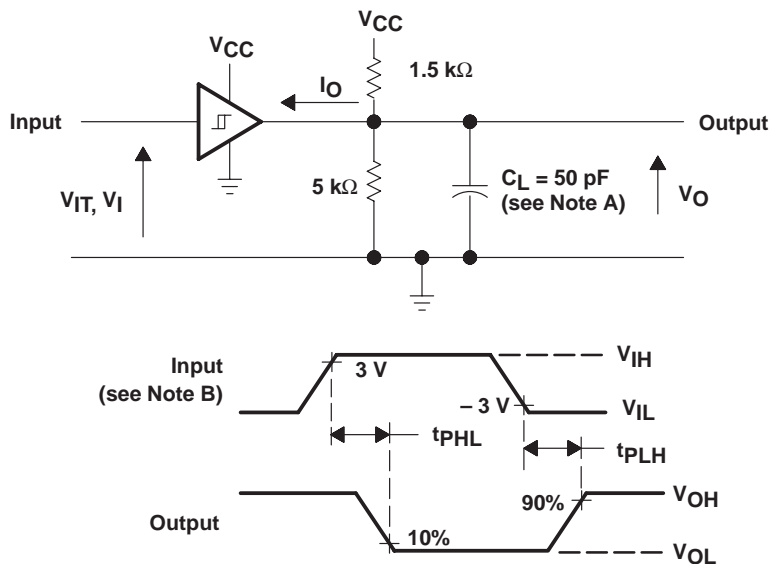
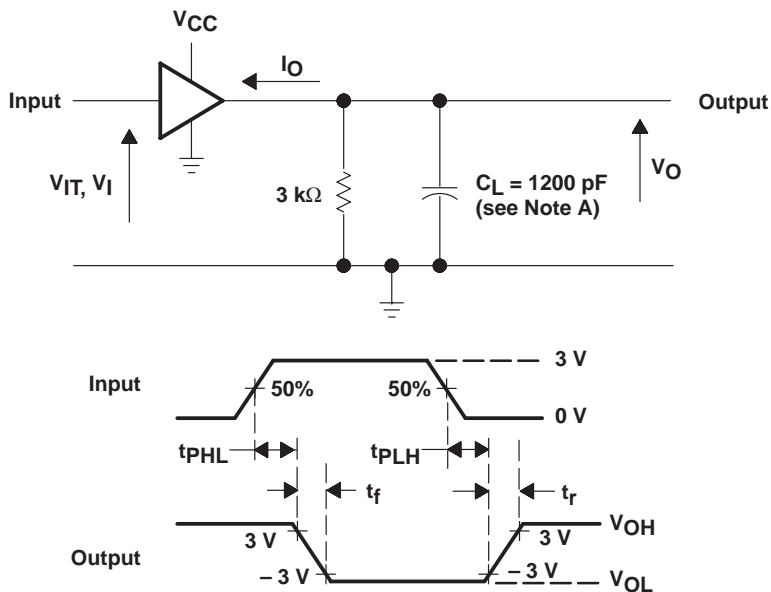

Figure 1. Receiver Test Circuit and Waveforms



- NOTES: A.  $C_L$  includes probe and jig capacitance.  
 B. The pulse generator has the following characteristics:  $t_w = 8.33 \mu s$ ,  $PRR = 60 \text{ kHz}$ ,  $t_r = t_f \leq 50 \text{ ns}$ .

Figure 2. Driver Test Circuit and Waveforms

# SN75LBC187 MULTICHANNEL EIA-232 DRIVER/RECEIVER WITH CHARGE PUMP

SLLS130C – SEPTEMBER 1991 – REVISED MAY 1995

## APPLICATION INFORMATION

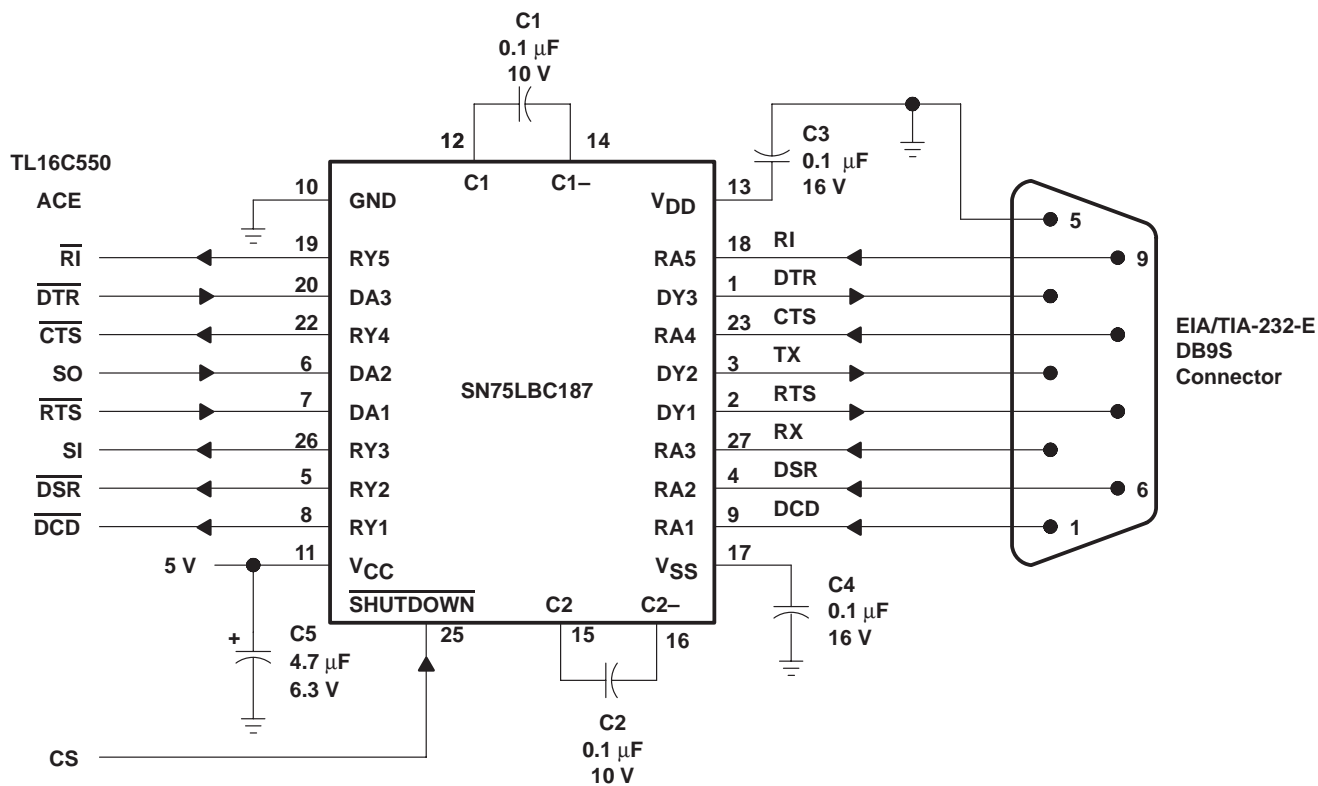

NOTE: C1, C2, C3, and C4 are Z5U-type ceramic-chip capacitors.

Figure 3. Typical SN75LBC187 Connection

**SN75LBC187**  
**MULTICHANNEL EIA-232 DRIVER/RECEIVER**  
**WITH CHARGE PUMP**

SLLS130C – SEPTEMBER 1991 – REVISED MAY 1995

**MECHANICAL DATA**

**DB (R-PDSO-G\*\*)**

**PLASTIC SMALL-OUTLINE PACKAGE**

28 PIN SHOWN

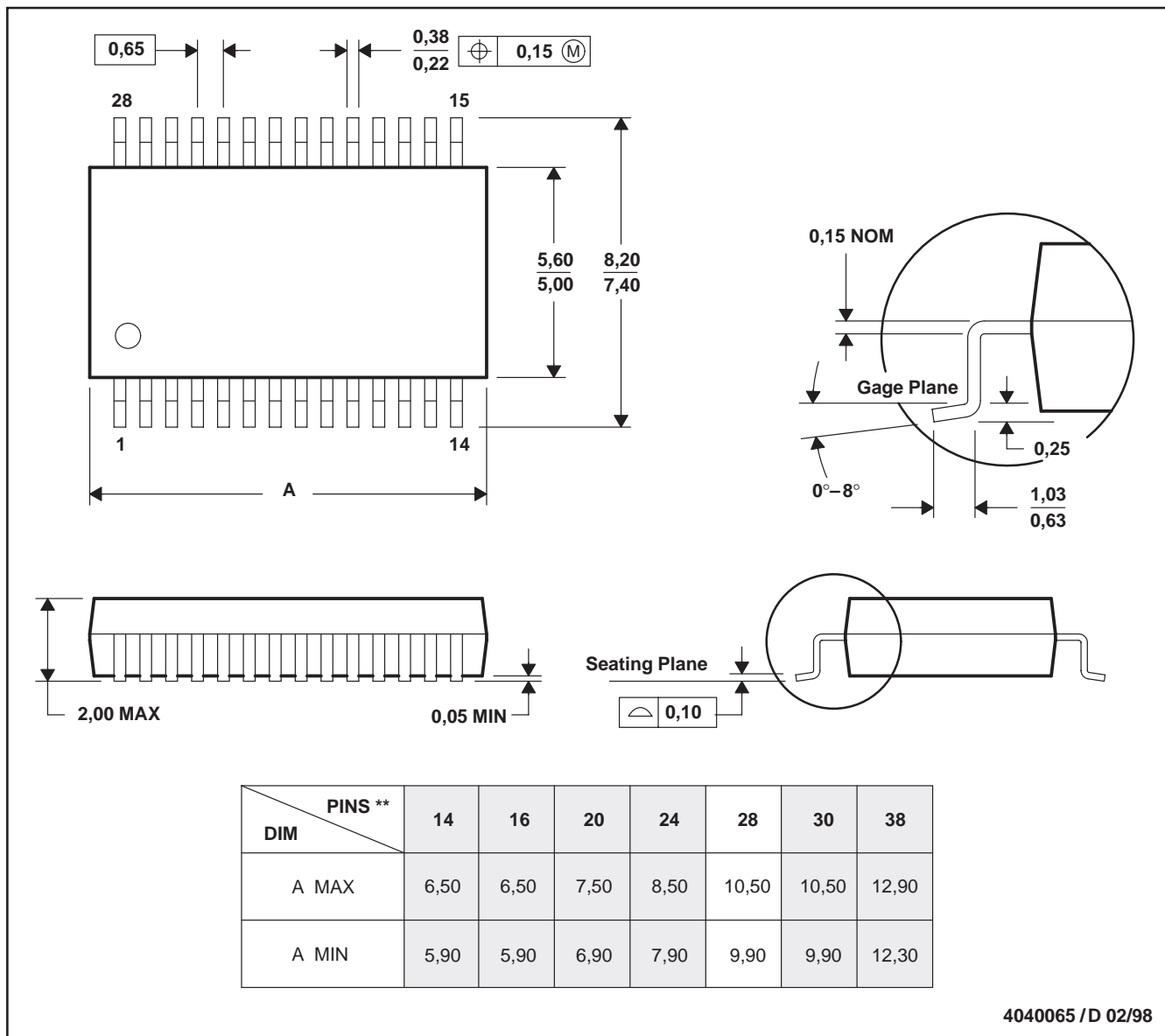

- NOTES: A. All linear dimensions are in millimeters.  
 B. This drawing is subject to change without notice.  
 C. Body dimensions do not include mold flash or protrusion not to exceed 0,15.  
 D. Falls within JEDEC MO-150

**PACKAGING INFORMATION**

Orderable Device	Status <sup>(1)</sup>	Package Type	Package Drawing	Pins	Package Qty	Eco Plan <sup>(2)</sup>	Lead/Ball Finish	MSL Peak Temp <sup>(3)</sup>
SN75LBC187DBLE	OBSOLETE	SSOP	DB	28		TBD	Call TI	Call TI
SN75LBC187DBR	ACTIVE	SSOP	DB	28	2000	Green (RoHS & no Sb/Br)	CU NIPDAU	Level-1-260C-UNLIM
SN75LBC187DBRE4	ACTIVE	SSOP	DB	28	2000	Green (RoHS & no Sb/Br)	CU NIPDAU	Level-1-260C-UNLIM
SN75LBC187DBRG4	ACTIVE	SSOP	DB	28	2000	Green (RoHS & no Sb/Br)	CU NIPDAU	Level-1-260C-UNLIM

<sup>(1)</sup> The marketing status values are defined as follows:

**ACTIVE:** Product device recommended for new designs.

**LIFEBUY:** TI has announced that the device will be discontinued, and a lifetime-buy period is in effect.

**NRND:** Not recommended for new designs. Device is in production to support existing customers, but TI does not recommend using this part in a new design.

**PREVIEW:** Device has been announced but is not in production. Samples may or may not be available.

**OBSOLETE:** TI has discontinued the production of the device.

<sup>(2)</sup> Eco Plan - The planned eco-friendly classification: Pb-Free (RoHS), Pb-Free (RoHS Exempt), or Green (RoHS & no Sb/Br) - please check <http://www.ti.com/productcontent> for the latest availability information and additional product content details.

**TBD:** The Pb-Free/Green conversion plan has not been defined.

**Pb-Free (RoHS):** TI's terms "Lead-Free" or "Pb-Free" mean semiconductor products that are compatible with the current RoHS requirements for all 6 substances, including the requirement that lead not exceed 0.1% by weight in homogeneous materials. Where designed to be soldered at high temperatures, TI Pb-Free products are suitable for use in specified lead-free processes.

**Pb-Free (RoHS Exempt):** This component has a RoHS exemption for either 1) lead-based flip-chip solder bumps used between the die and package, or 2) lead-based die adhesive used between the die and leadframe. The component is otherwise considered Pb-Free (RoHS compatible) as defined above.

**Green (RoHS & no Sb/Br):** TI defines "Green" to mean Pb-Free (RoHS compatible), and free of Bromine (Br) and Antimony (Sb) based flame retardants (Br or Sb do not exceed 0.1% by weight in homogeneous material)

<sup>(3)</sup> MSL, Peak Temp. -- The Moisture Sensitivity Level rating according to the JEDEC industry standard classifications, and peak solder temperature.

**Important Information and Disclaimer:**The information provided on this page represents TI's knowledge and belief as of the date that it is provided. TI bases its knowledge and belief on information provided by third parties, and makes no representation or warranty as to the accuracy of such information. Efforts are underway to better integrate information from third parties. TI has taken and continues to take reasonable steps to provide representative and accurate information but may not have conducted destructive testing or chemical analysis on incoming materials and chemicals. TI and TI suppliers consider certain information to be proprietary, and thus CAS numbers and other limited information may not be available for release.

In no event shall TI's liability arising out of such information exceed the total purchase price of the TI part(s) at issue in this document sold by TI to Customer on an annual basis.



**TAPE AND REEL BOX INFORMATION**



A0	Dimension designed to accommodate the component width
B0	Dimension designed to accommodate the component length
K0	Dimension designed to accommodate the component thickness
W	Overall width of the carrier tape
P1	Pitch between successive cavity centers

**QUADRANT ASSIGNMENTS FOR PIN 1 ORIENTATION IN TAPE**



Device	Package	Pins	Site	Reel Diameter (mm)	Reel Width (mm)	A0 (mm)	B0 (mm)	K0 (mm)	P1 (mm)	W (mm)	Pin1 Quadrant
SN75LBC187DBR	DB	28	SITE 41	330	16	8.2	10.5	2.5	12	16	Q1

**TAPE AND REEL BOX DIMENSIONS**



Device	Package	Pins	Site	Length (mm)	Width (mm)	Height (mm)
SN75LBC187DBR	DB	28	SITE 41	346.0	346.0	33.0

DB (R-PDSO-G\*\*)

PLASTIC SMALL-OUTLINE

28 PINS SHOWN



- NOTES: A. All linear dimensions are in millimeters.  
 B. This drawing is subject to change without notice.  
 C. Body dimensions do not include mold flash or protrusion not to exceed 0,15.  
 D. Falls within JEDEC MO-150

4040065 /E 12/01

## IMPORTANT NOTICE

Texas Instruments Incorporated and its subsidiaries (TI) reserve the right to make corrections, modifications, enhancements, improvements, and other changes to its products and services at any time and to discontinue any product or service without notice. Customers should obtain the latest relevant information before placing orders and should verify that such information is current and complete. All products are sold subject to TI's terms and conditions of sale supplied at the time of order acknowledgment.

TI warrants performance of its hardware products to the specifications applicable at the time of sale in accordance with TI's standard warranty. Testing and other quality control techniques are used to the extent TI deems necessary to support this warranty. Except where mandated by government requirements, testing of all parameters of each product is not necessarily performed.

TI assumes no liability for applications assistance or customer product design. Customers are responsible for their products and applications using TI components. To minimize the risks associated with customer products and applications, customers should provide adequate design and operating safeguards.

TI does not warrant or represent that any license, either express or implied, is granted under any TI patent right, copyright, mask work right, or other TI intellectual property right relating to any combination, machine, or process in which TI products or services are used. Information published by TI regarding third-party products or services does not constitute a license from TI to use such products or services or a warranty or endorsement thereof. Use of such information may require a license from a third party under the patents or other intellectual property of the third party, or a license from TI under the patents or other intellectual property of TI.

Reproduction of TI information in TI data books or data sheets is permissible only if reproduction is without alteration and is accompanied by all associated warranties, conditions, limitations, and notices. Reproduction of this information with alteration is an unfair and deceptive business practice. TI is not responsible or liable for such altered documentation. Information of third parties may be subject to additional restrictions.

Resale of TI products or services with statements different from or beyond the parameters stated by TI for that product or service voids all express and any implied warranties for the associated TI product or service and is an unfair and deceptive business practice. TI is not responsible or liable for any such statements.

TI products are not authorized for use in safety-critical applications (such as life support) where a failure of the TI product would reasonably be expected to cause severe personal injury or death, unless officers of the parties have executed an agreement specifically governing such use. Buyers represent that they have all necessary expertise in the safety and regulatory ramifications of their applications, and acknowledge and agree that they are solely responsible for all legal, regulatory and safety-related requirements concerning their products and any use of TI products in such safety-critical applications, notwithstanding any applications-related information or support that may be provided by TI. Further, Buyers must fully indemnify TI and its representatives against any damages arising out of the use of TI products in such safety-critical applications.

TI products are neither designed nor intended for use in military/aerospace applications or environments unless the TI products are specifically designated by TI as military-grade or "enhanced plastic." Only products designated by TI as military-grade meet military specifications. Buyers acknowledge and agree that any such use of TI products which TI has not designated as military-grade is solely at the Buyer's risk, and that they are solely responsible for compliance with all legal and regulatory requirements in connection with such use.

TI products are neither designed nor intended for use in automotive applications or environments unless the specific TI products are designated by TI as compliant with ISO/TS 16949 requirements. Buyers acknowledge and agree that, if they use any non-designated products in automotive applications, TI will not be responsible for any failure to meet such requirements.

Following are URLs where you can obtain information on other Texas Instruments products and application solutions:

<b>Products</b>		<b>Applications</b>	
Amplifiers	<a href="http://amplifier.ti.com">amplifier.ti.com</a>	Audio	<a href="http://www.ti.com/audio">www.ti.com/audio</a>
Data Converters	<a href="http://dataconverter.ti.com">dataconverter.ti.com</a>	Automotive	<a href="http://www.ti.com/automotive">www.ti.com/automotive</a>
DSP	<a href="http://dsp.ti.com">dsp.ti.com</a>	Broadband	<a href="http://www.ti.com/broadband">www.ti.com/broadband</a>
Interface	<a href="http://interface.ti.com">interface.ti.com</a>	Digital Control	<a href="http://www.ti.com/digitalcontrol">www.ti.com/digitalcontrol</a>
Logic	<a href="http://logic.ti.com">logic.ti.com</a>	Military	<a href="http://www.ti.com/military">www.ti.com/military</a>
Power Mgmt	<a href="http://power.ti.com">power.ti.com</a>	Optical Networking	<a href="http://www.ti.com/opticalnetwork">www.ti.com/opticalnetwork</a>
Microcontrollers	<a href="http://microcontroller.ti.com">microcontroller.ti.com</a>	Security	<a href="http://www.ti.com/security">www.ti.com/security</a>
RFID	<a href="http://www.ti-rfid.com">www.ti-rfid.com</a>	Telephony	<a href="http://www.ti.com/telephony">www.ti.com/telephony</a>
Low Power Wireless	<a href="http://www.ti.com/lpw">www.ti.com/lpw</a>	Video & Imaging	<a href="http://www.ti.com/video">www.ti.com/video</a>
		Wireless	<a href="http://www.ti.com/wireless">www.ti.com/wireless</a>

Mailing Address: Texas Instruments, Post Office Box 655303, Dallas, Texas 75265  
Copyright © 2007, Texas Instruments Incorporated