

# SN54AS1000A, SN74AS1000A QUADRUPLE 2-INPUT POSITIVE-NAND BUFFERS/DRIVERS

SDAS056B - APRIL 1984 - REVISED JANUARY 1995

- Driver Version of 'AS00
- High Capacitive-Drive Capability
- Package Options Include Plastic Small-Outline (D) Packages, Ceramic Chip Carriers (FK), and Standard Plastic (N) and Ceramic (J) 300-mil DIPs

## description

These devices contain four independent 2-input positive-NAND buffers/drivers. They perform the Boolean functions  $Y = \overline{A \cdot B}$  or  $Y = \overline{A} + \overline{B}$  in positive logic.

The SN54AS1000A is characterized for operation over the full military temperature range of  $-55^{\circ}\text{C}$  to  $125^{\circ}\text{C}$ . The SN74AS1000A is characterized for operation from  $0^{\circ}\text{C}$  to  $70^{\circ}\text{C}$ .

FUNCTION TABLE  
(each gate)

INPUTS		OUTPUT
A	B	Y
H	H	L
L	X	H
X	L	H

SN54AS1000A . . . J PACKAGE  
SN74AS1000A . . . D OR N PACKAGE  
(TOP VIEW)

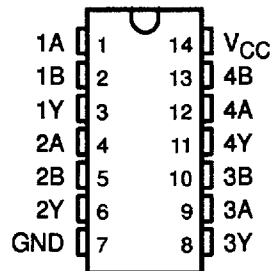

SN54AS1000A . . . FK PACKAGE  
(TOP VIEW)

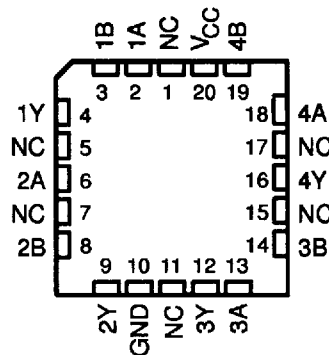

NC - No internal connection

## logic symbol†

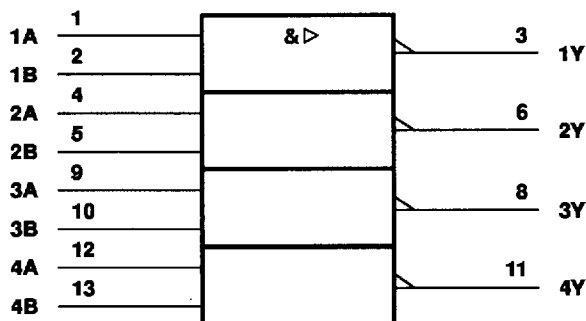

## logic diagram (positive logic)

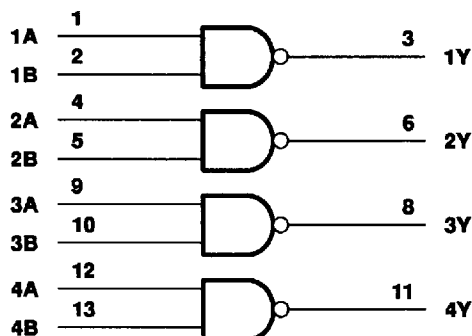

† This symbol is in accordance with ANSI/IEEE Std 91-1984 and IEC Publication 617-12.

Pin numbers shown are for the D, J, and N packages.

# SN54AS1000A, SN74AS1000A QUADRUPLE 2-INPUT POSITIVE-NAND BUFFERS/DRIVERS

SDAS056B - APRIL 1984 - REVISED JANUARY 1995

## absolute maximum ratings over operating free-air temperature range (unless otherwise noted)†

Supply voltage, $V_{CC}$ .....	7 V
Input voltage, $V_I$ .....	7 V
Operating free-air temperature range, $T_A$ : SN54AS1000A .....	-55°C to 125°C
SN74AS1000A .....	0°C to 70°C
Storage temperature range .....	-65°C to 150°C

† Stresses beyond those listed under "absolute maximum ratings" may cause permanent damage to the device. These are stress ratings only, and functional operation of the device at these or any other conditions beyond those indicated under "recommended operating conditions" is not implied. Exposure to absolute-maximum-rated conditions for extended periods may affect device reliability.

## recommended operating conditions‡

	SN54AS1000A			SN74AS1000A			UNIT
	MIN	NOM	MAX	MIN	NOM	MAX	
$V_{CC}$ Supply voltage	4.5	5	5.5	4.5	5	5.5	V
$V_{IH}$ High-level input voltage	2			2			V
$V_{IL}$ Low-level input voltage			0.8			0.8	V
$I_{OH}$ High-level output current			-40			-48	mA
$I_{OL}$ Low-level output current			40			48	mA
$T_A$ Operating free-air temperature	-55		125	0		70	°C

‡ These high sink- or source-current devices are not recommended for use above 40 MHz.

## electrical characteristics over recommended operating free-air temperature range (unless otherwise noted)

PARAMETER	TEST CONDITIONS	SN54AS1000A			SN74AS1000A			UNIT	
		MIN	TYP§	MAX	MIN	TYP§	MAX		
$V_{IK}$	$V_{CC} = 4.5 V$ , $I_I = -18 mA$			-1.2			-1.2	V	
$V_{OH}$	$V_{CC} = 4.5 V$ to $5.5 V$ , $I_{OH} = -2 mA$	$V_{CC} - 2$			$V_{CC} - 2$			V	
	$V_{CC} = 4.5 V$	$I_{OH} = -3 mA$		2.4	3.2		2.4		3.2
		$I_{OH} = -40 mA$		2					
		$I_{OH} = -48 mA$					2		
$V_{OL}$	$V_{CC} = 4.5 V$	$I_{OL} = 40 mA$		0.25	0.5		V		
		$I_{OL} = 48 mA$						0.35	0.5
$I_I$	$V_{CC} = 5.5 V$ , $V_I = 7 V$			0.1			0.1	mA	
$I_{IH}$	$V_{CC} = 5.5 V$ , $V_I = 2.7 V$			20			20	µA	
$I_{IL}$	$V_{CC} = 5.5 V$ , $V_I = 0.4 V$			-0.5			-0.5	mA	
$I_{O\ddagger}$	$V_{CC} = 5.5 V$ , $V_O = 2.25 V$	-30		-200	-50		-200	mA	
$I_{CCH}$	$V_{CC} = 5.5 V$ , $V_I = 0$		2.2	3.5		2.2	3.5	mA	
$I_{CCL}$	$V_{CC} = 5.5 V$ , $V_I = 4.5 V$		12	19		12	19	mA	

§ All typical values are at  $V_{CC} = 5 V$ ,  $T_A = 25^\circ C$ .

‡ The output conditions have been chosen to produce a current that closely approximates one half of the true short-circuit output current,  $I_{OS}$ .



POST OFFICE BOX 655303 • DALLAS, TEXAS 75265

# SN54AS1000A, SN74AS1000A QUADRUPLE 2-INPUT POSITIVE-NAND BUFFERS/DRIVERS

SDAS056B - APRIL 1984 - REVISED JANUARY 1995

## switching characteristics (see Figure 1)

PARAMETER	FROM (INPUT)	TO (OUTPUT)	$V_{CC} = 4.5 \text{ V to } 5.5 \text{ V},$ $C_L = 50 \text{ pF},$ $R_L = 500 \Omega,$ $T_A = \text{MIN to MAX}^\dagger$				UNIT
			SN54AS1000A		SN74AS1000A		
			MIN	MAX	MIN	MAX	
$t_{PLH}$	A or B	Y	1	5	1	4	ns
$t_{PHL}$			1	5	1	4	

† For conditions shown as MIN or MAX, use the appropriate value specified under recommended operating conditions.



POST OFFICE BOX 655303 • DALLAS, TEXAS 75265

# SN54AS1000A, SN74AS1000A QUADRUPLE 2-INPUT POSITIVE-NAND BUFFERS/DRIVERS

SDAS056B - APRIL 1984 - REVISED JANUARY 1995

## PARAMETER MEASUREMENT INFORMATION SERIES 54ALS/74ALS AND 54AS/74AS DEVICES

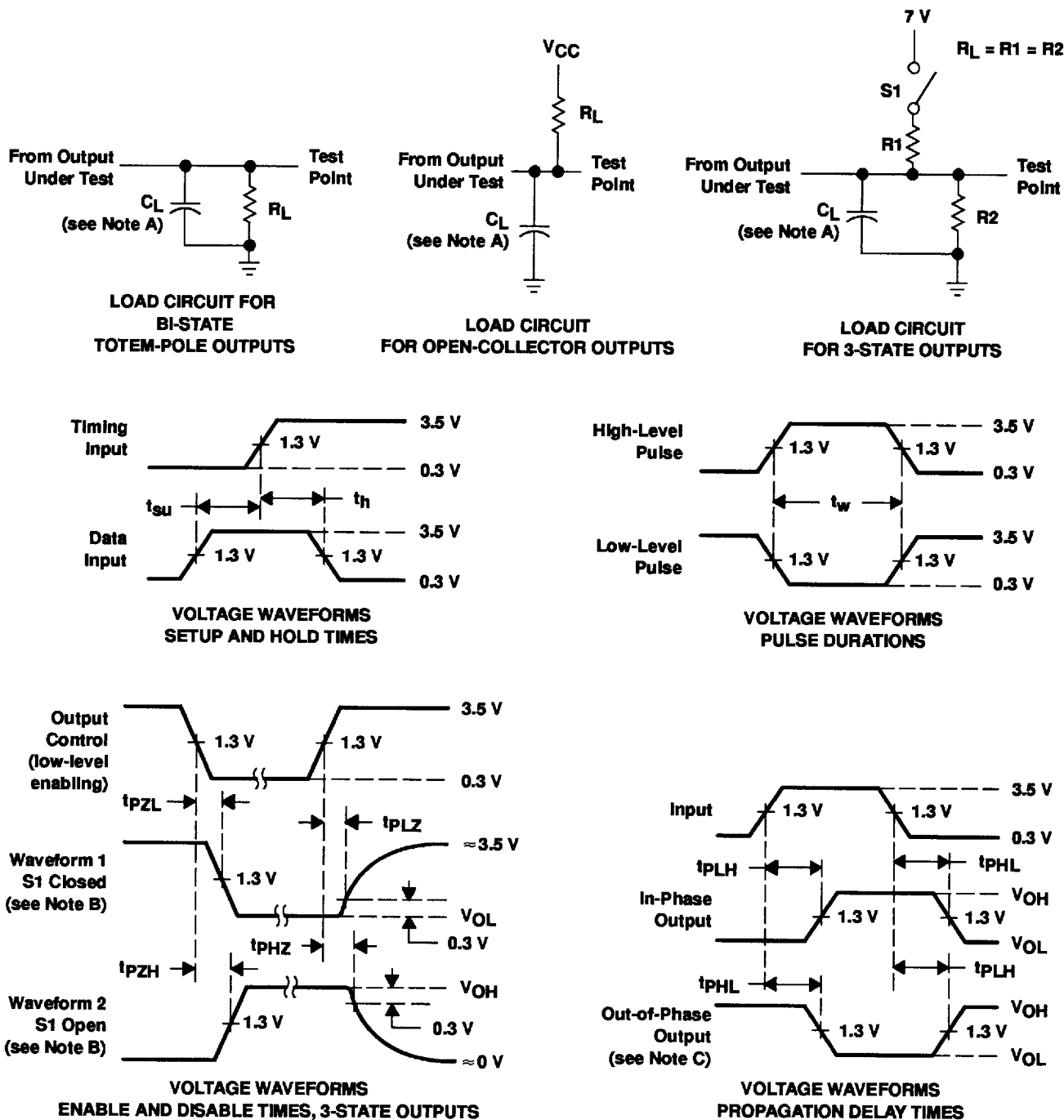

- NOTES: A.  $C_L$  includes probe and jig capacitance.  
 B. Waveform 1 is for an output with internal conditions such that the output is low except when disabled by the output control. Waveform 2 is for an output with internal conditions such that the output is high except when disabled by the output control.  
 C. When measuring propagation delay items of 3-state outputs, switch S1 is open.  
 D. All input pulses have the following characteristics:  $PRR \leq 1$  MHz,  $t_r = t_f = 2$  ns, duty cycle = 50%.  
 E. The outputs are measured one at a time with one transition per measurement.

Figure 1. Load Circuits and Voltage Waveforms

**TEXAS  
INSTRUMENTS**

POST OFFICE BOX 655303 • DALLAS, TEXAS 75265

8961723 0104419 097