

Silicon Bipolar MMIC-Amplifier

Preliminary data

- Cascadable 50 Ω -gain block
- 9 dB typical gain at 1.0 GHz
- 9 dBm typical P_{-1dB} at 1.0 GHz
- 3 dB-bandwidth: DC to 2.4 GHz

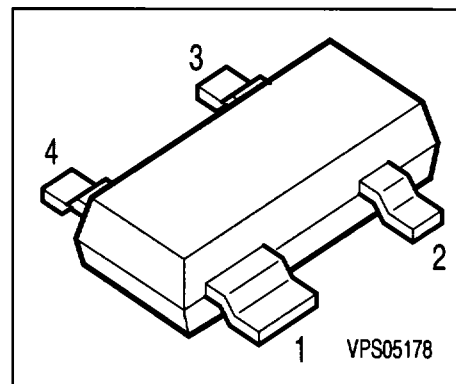

Circuit Diagram

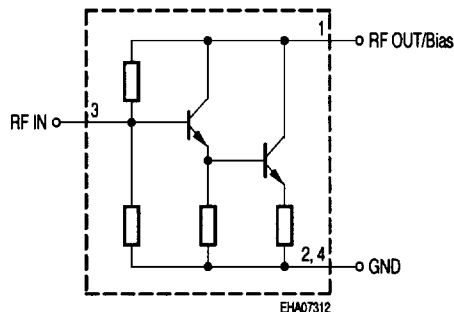

Type	Marking	Ordering Code	Pin Configuration				Package
BGA 310	BLs	Q62702-G0041	1 RFout/bias	2 GND	3 RF input	4 GND	SOT-143

Maximum Ratings

Parameter	Symbol	Value	Unit
Device current	I_D	60	mA
Total power dissipation, $T_S \leq 99^\circ\text{C}$	P_{tot}	250	mW
R_F input power	P_{RFIn}	10	dBm
Junction temperature	T_j	150	°C
Ambient temperature	T_A	-65 ...+150	
Storage temperature	T_{stg}	-65 ...+150	

Thermal Resistance

Junction - soldering point ¹⁾	R_{thJS}	≤ 205	K/W
--	------------	------------	-----

1) T_S is measured on the collector lead at the soldering point to the pcb

Electrical Characteristics at $T_A = 25\text{ }^\circ\text{C}$, unless otherwise specified.

Parameter	Symbol	Values			Unit
		min.	typ.	max.	
AC characteristics ($V_D = 4.7\text{ V}$, $Z_0 = 50\text{ }\Omega$)					
Insertion power gain $f = 0.1\text{ GHz}$ $f = 1\text{ GHz}$ $f = 1.8\text{ GHz}$	$ S_{21} ^2$	-	10 9 8	-	dB
Insertion point gain flatness $f = 0.1\text{ GHz to } 0.6\text{ GHz}$	$\Delta S_{21} ^2$	-	+0.5	-	
Noise figure $f = 0.1\text{ GHz}$ $f = 1\text{ GHz}$ $f = 2\text{ GHz}$	NF	-	6 6.5 7	-	
1dB compression point $f = 1\text{ GHz}$	P_{-1dB}	-	9	-	dBm
Return loss input $f = 0.1\text{ GHz to } 2\text{ GHz}$	RL_{in}	-	20	-	dB
Return loss output $f = 0.1\text{ GHz to } 3\text{ GHz}$	RL_{out}	-	15	-	

Typical biasing configuration

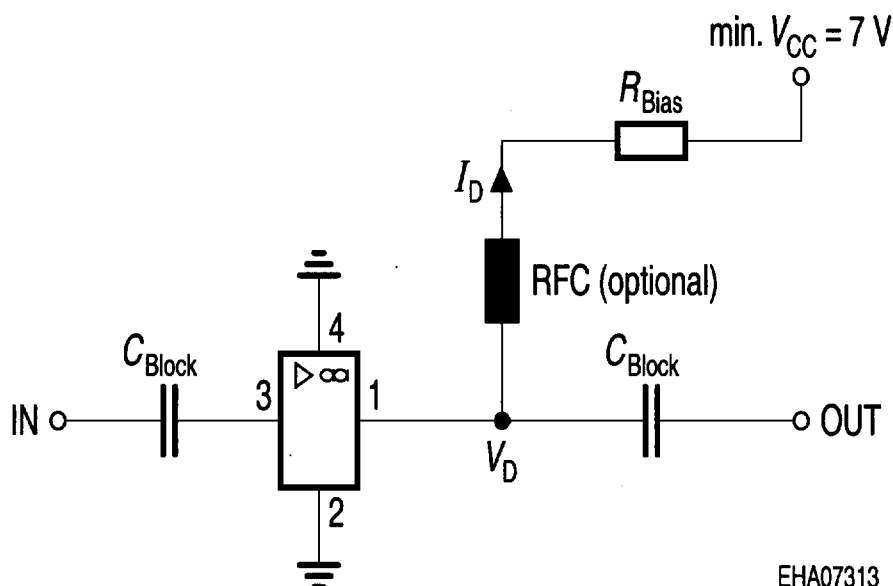

S-Parameters at $T_A = 25\text{ °C}$

f	S_{11}		S_{21}		S_{12}		S_{22}	
	MAG	ANG	MAG	ANG	MAG	ANG	MAG	ANG
GHz								
$V_D = 4.7\text{ V}, Z_0 = 50\Omega$								
0.01	0.051	176.4	3.22	179.3	0.149	0.2	0.159	-0.5
0.1	0.053	168.1	3.23	174.9	0.149	1.2	0.158	-6.1
0.3	0.053	141.9	3.22	164.6	0.15	3.4	0.157	-19
0.5	0.058	123.9	3.2	154.2	0.152	5.4	0.155	-31.7
0.8	0.054	98.2	3.17	138.7	0.157	8.1	0.153	-51.3
1	0.049	86.1	3.12	128.4	0.162	9.7	0.153	-64.3
1.8	0.053	-164.9	2.79	88	0.188	12	0.16	-106.6
2.4	0.161	-177.7	2.41	60.8	0.208	10.6	0.168	-123.7
3	0.257	153.9	2.03	38.2	0.225	8.2	0.178	-133.1

Insertion power gain $|S_{21}|^2 = f(f)$

$V_D = 4.7\text{ V}, I_D = 42\text{ mA}$

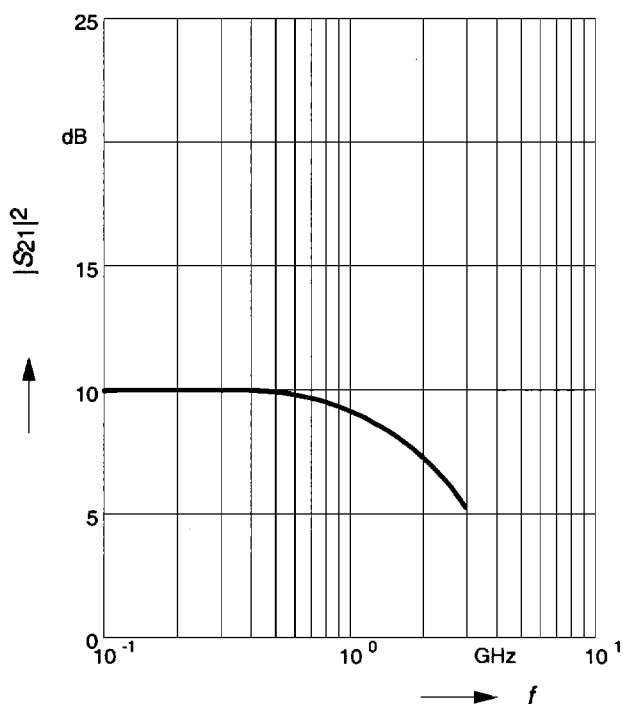

Noise figure $NF = f(f)$

$V_D = 4.7\text{ V}, I_D = 42\text{ mA}$

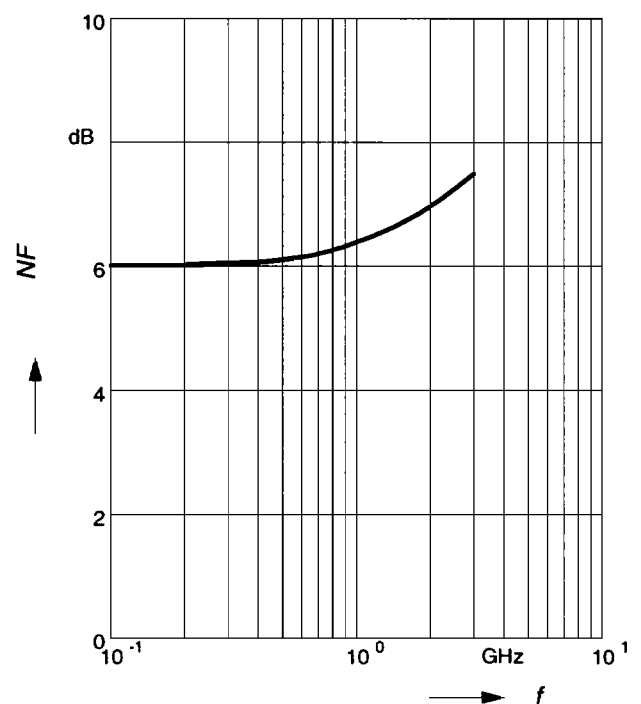

Output power 1-dB-gain compression

$$P_{-1dB} = f(f)$$

$$V_D = 4.7 \text{ V}, I_D = 42 \text{ mA}$$

