

54174/DM54174/DM74174, 54175/DM54175/DM74175 Hex/Quad D Flip-Flops with Clear

General Description

These positive-edge triggered flip-flops utilize TTL circuitry to implement D-type flip-flop logic. All have a direct clear input, and the quad (175) version features complementary outputs from each flip-flop.

Information at the D inputs meeting the setup and hold time requirements is transferred to the Q outputs on the positive-going edge of the clock pulse. Clock triggering occurs at a particular voltage level and is not directly related to the transition time of the positive-going pulse. When the clock input is at either the high or low level, the D input signal has no effect at the output.

Features

- 174 contains six flip-flops with single-rail outputs
- 175 contains four flip-flops with double-rail outputs
- Buffered clock and direct clear inputs
- Individual data input to each flip-flop
- Applications include:
 - Buffer/storage registers
 - Shift registers
 - Pattern generators
- Typical clock frequency 40 MHz
- Typical power dissipation per flip-flop 38 mW
- Alternate Military/Aerospace device (54174, 54175) is available. Contact a National Semiconductor Sales Office/Distributor for specifications.

Connection Diagrams

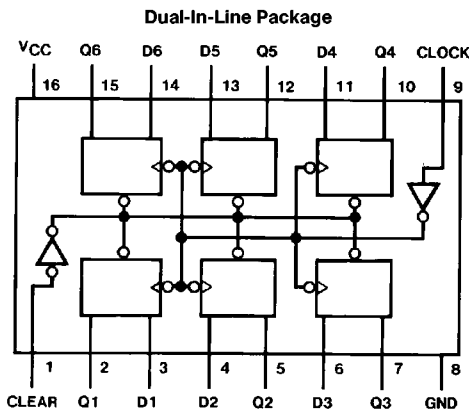

Order Number 54174DMQB, 54174FMQB, DM54174J,
DM54174W or DM74174N
See NS Package Number J16A, N16E or W16A

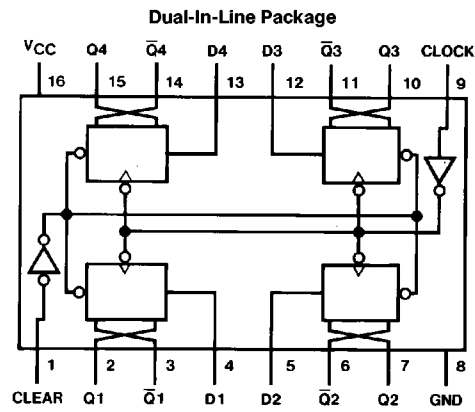

Order Number 54175DMQB, 54175FMQB, DM54175J,
DM54175W or DM74175N
See NS Package Number J16A, N16E or W16A

Function Table (Each Flip-Flop)

Inputs			Outputs	
Clear	Clock	D	Q	Q̄†
L	X	X	L	H
H	↑	H	H	L
H	↑	L	L	H
H	L	X	Q ₀	Q̄ ₀

H = High Level (steady state)

L = Low Level (steady state)

X = Don't Care

↑ = Transition from low to high level

Q₀ = The level of Q before the indicated steady-state input conditions were established.

† = 175 only

Absolute Maximum Ratings (Note)

If Military/Aerospace specified devices are required, please contact the National Semiconductor Sales Office/Distributors for availability and specifications.

Supply Voltage	7V
Input Voltage	5.5V
Operating Free Air Temperature Range	
DM54 and 54	-55°C to +125°C
DM74	0°C to +70°C
Storage Temperature Range	-65°C to +150°C

Note: The "Absolute Maximum Ratings" are those values beyond which the safety of the device cannot be guaranteed. The device should not be operated at these limits. The parametric values defined in the "Electrical Characteristics" table are not guaranteed at the absolute maximum ratings. The "Recommended Operating Conditions" table will define the conditions for actual device operation.

Recommended Operating Conditions

Symbol	Parameter	DM54174			DM74174			Units
		Min	Nom	Max	Min	Nom	Max	
V _{CC}	Supply Voltage	4.5	5	5.5	4.75	5	5.25	V
V _{IH}	High Level Input Voltage	2			2			V
V _{IL}	Low Level Input Voltage			0.8			0.8	V
I _{OH}	High Level Output Current			-0.8			-0.8	mA
I _{OL}	Low Level Output Current			16			16	mA
f _{CLK}	Clock Frequency (Note 4)	0		30	0		30	MHz
t _w	Pulse Width (Note 4)	Clock Low	25		25			ns
		Clock High	10		10			
		Clear	20		20			
t _{SU}	Data Setup Time (Note 4)	20			20			ns
t _H	Data Hold Time (Note 4)	0			0			ns
t _{REL}	Clear Release Time (Note 4)	30			30			ns
T _A	Free Air Operating Temperature	-55		125	0		70	°C

174 Electrical Characteristics

over recommended operating free air temperature range (unless otherwise noted)

Symbol	Parameter	Conditions	Min	Typ (Note 1)	Max	Units
V _I	Input Clamp Voltage	V _{CC} = Min, I _I = -12 mA			-1.5	V
V _{OH}	High Level Output Voltage	V _{CC} = Min, I _{OH} = Max V _{IL} = Max, V _{IH} = Min	2.4			V
V _{OL}	Low Level Output Voltage	V _{CC} = Min, I _{OL} = Max V _{IH} = Min, V _{IL} = Max			0.4	V
I _I	Input Current @ Max Input Voltage	V _{CC} = Max, V _I = 5.5V			1	mA
I _{IH}	High Level Input Current	V _{CC} = Max, V _I = 2.4V			40	μA
I _{IL}	Low Level Input Current	V _{CC} = Max, V _I = 0.4V			-1.6	mA
I _{OS}	Short Circuit Output Current	V _{CC} = Max (Note 2)	DM54	-20	-57	mA
			DM74	-18	-57	
I _{CC}	Supply Current	V _{CC} = Max (Note 3)		45	65	mA

Note 1: All typicals are at V_{CC} = 5V, T_A = 25°C.

Note 2: Not more than one output should be shorted at a time.

Note 3: With all outputs open and all DATA and CLEAR inputs at 4.5V, I_{CC} is measured after a momentary ground, then 4.5V applied to the CLOCK input.

Note 4: T_A = 25°C and V_{CC} = 5V.

'174 Switching Characteristics

at $V_{CC} = 5V$ and $T_A = 25^\circ C$ (See Section 1 for Test Waveforms and Output Load)

Symbol	Parameter	From (Input) To (Output)	$R_L = 400\Omega, C_L = 15\text{ pF}$		Units
			Min	Max	
f_{MAX}	Maximum Clock Frequency		30		MHz
t_{PLH}	Propagation Delay Time Low to High Level Output	Clock to Any Q		25	ns
t_{PHL}	Propagation Delay Time High to Low Level Output	Clock to Any Q		25	ns
t_{PHL}	Propagation Delay Time High to Low Level Output	Clear to Any Q		40	ns

Recommended Operating Conditions

Symbol	Parameter	DM54175			DM74175			Units
		Min	Nom	Max	Min	Nom	Max	
V_{CC}	Supply Voltage	4.5	5	5.5	4.75	5	5.25	V
V_{IH}	High Level Input Voltage	2			2			V
V_{IL}	Low Level Input Voltage			0.8			0.8	V
I_{OH}	High Level Output Current			-0.8			-0.8	mA
I_{OL}	Low Level Output Current			16			16	mA
f_{CLK}	Clock Frequency (Note 1)	0		30	0		30	MHz
t_W	Pulse Width (Note 1)	Clock Low	25		25			ns
		Clock High	10		10			
		Clear	20		20			
t_{SU}	Data Setup Time (Note 1)	20			20			ns
t_H	Data Hold Time (Note 1)	0			0			ns
t_{REL}	Clear Release Time (Note 1)	30			30			ns
T_A	Free Air Operating Temperature	-55		125	0		70	$^\circ C$

Note 1: $T_A = 25^\circ C$ and $V_{CC} = 5V$.

'175 Electrical Characteristics

over recommended operating free air temperature range (unless otherwise noted)

Symbol	Parameter	Conditions	Min	Typ (Note 1)	Max	Units
V_I	Input Clamp Voltage	$V_{CC} = \text{Min}, I_I = -12 \text{ mA}$			-1.5	V
V_{OH}	High Level Output Voltage	$V_{CC} = \text{Min}, I_{OH} = \text{Max}$ $V_{IL} = \text{Max}, V_{IH} = \text{Min}$	2.4			V
V_{OL}	Low Level Output Voltage	$V_{CC} = \text{Min}, I_{OL} = \text{Max}$ $V_{IH} = \text{Min}, V_{IL} = \text{Max}$			0.4	V
I_I	Input Current @ Max Input Voltage	$V_{CC} = \text{Max}, V_I = 5.5\text{V}$			1	mA
I_{IH}	High Level Input Current	$V_{CC} = \text{Max}, V_I = 2.4\text{V}$			40	μA
I_{IL}	Low Level Input Current	$V_{CC} = \text{Max}, V_I = 0.4\text{V}$			-1.6	mA
I_{OS}	Short Circuit Output Current	$V_{CC} = \text{Max}$ (Note 2)	DM54	-20	-57	mA
			DM74	-18	-57	
I_{CC}	Supply Current	$V_{CC} = \text{Max}$ (Note 3)		30	45	mA

'175 Switching Characteristics

at $V_{CC} = 5\text{V}$ and $T_A = 25^\circ\text{C}$ (See Section 1 for Test Waveforms and Output Load)

Symbol	Parameter	From (Input) To (Output)	$R_L = 400\Omega, C_L = 15 \text{ pF}$		Units
			Min	Max	
f_{MAX}	Maximum Clock Frequency		30		MHz
t_{PLH}	Propagation Delay Time Low to High Level Output	Clock to Any Q or \bar{Q}		25	ns
t_{PHL}	Propagation Delay Time High to Low Level Output	Clock to Any Q or \bar{Q}		25	ns
t_{PLH}	Propagation Delay Time Low to High Level Output	Clear to Any \bar{Q}		25	ns
t_{PHL}	Propagation Delay Time High to Low Level Output	Clear to Any Q		40	ns

Note 1: All typicals are at $V_{CC} = 5\text{V}$, $T_A = 25^\circ\text{C}$.

Note 2: Not more than one output should be shorted at a time.

Note 3: With all outputs open and 4.5V applied to all DATA and CLEAR inputs, I_{CC} is measured after a momentary ground then 4.5V applied to the CLOCK.

Logic Diagrams

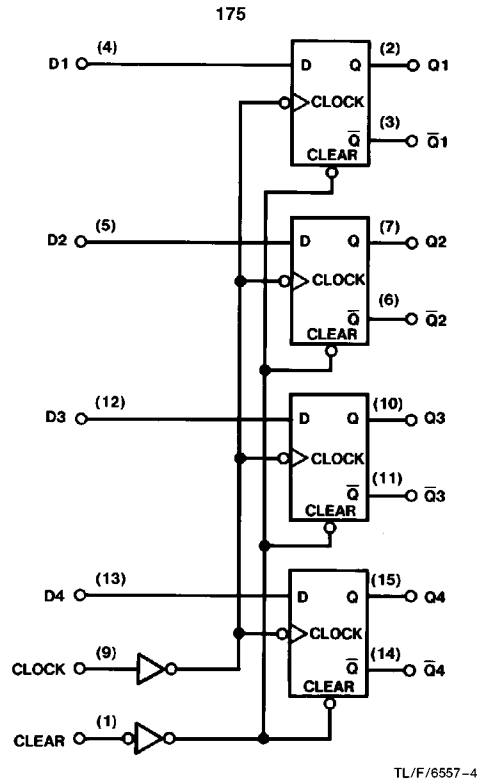
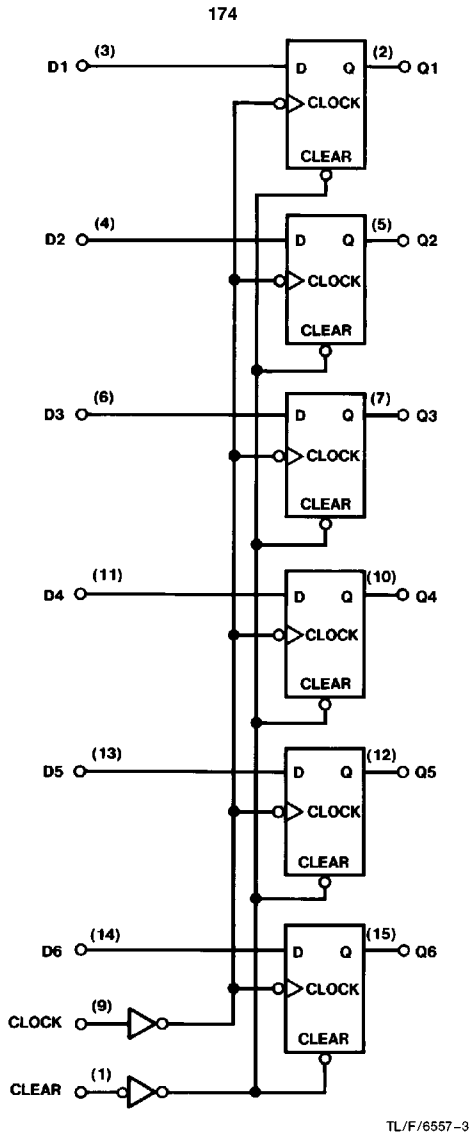

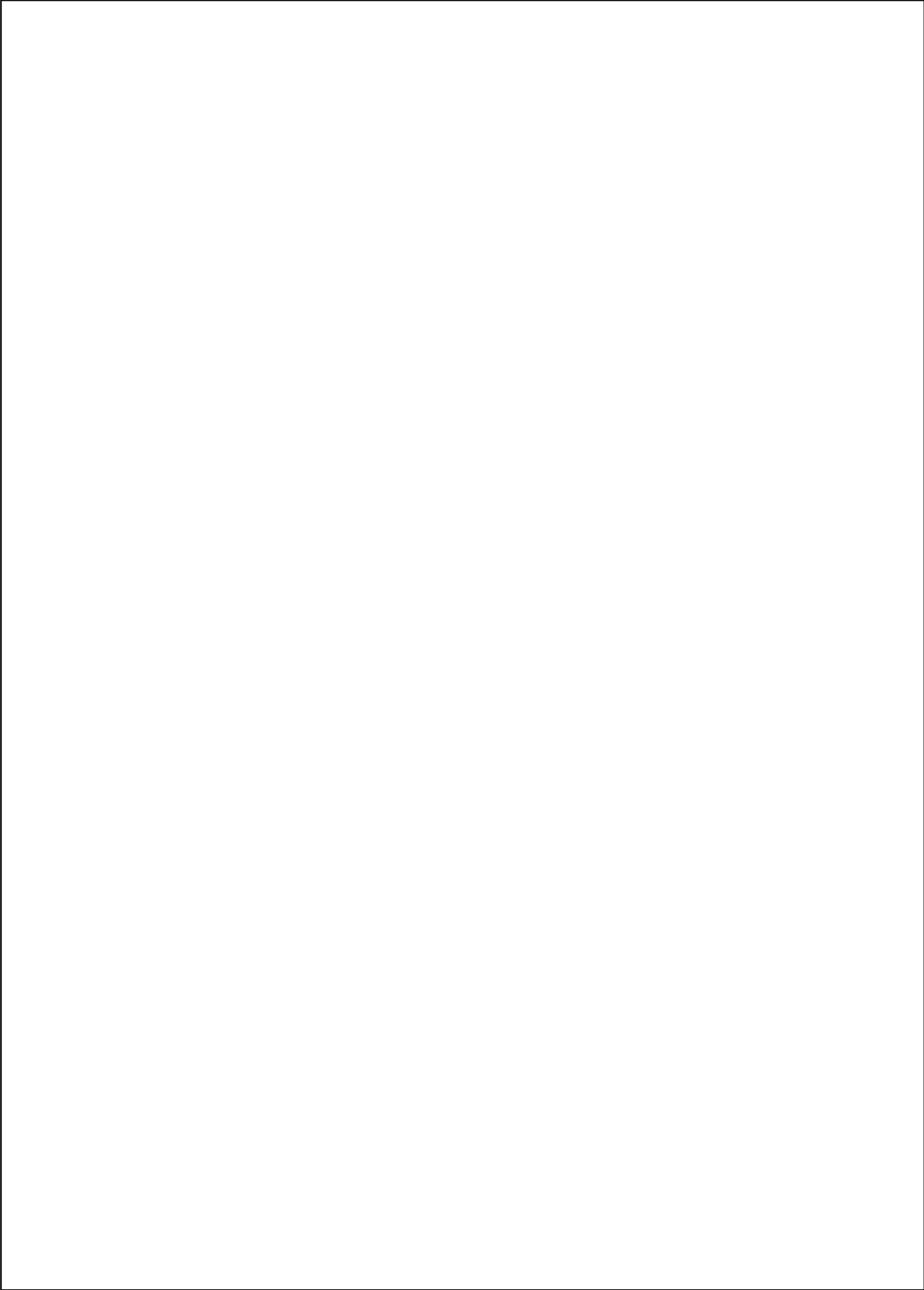

Physical Dimensions inches (millimeters)

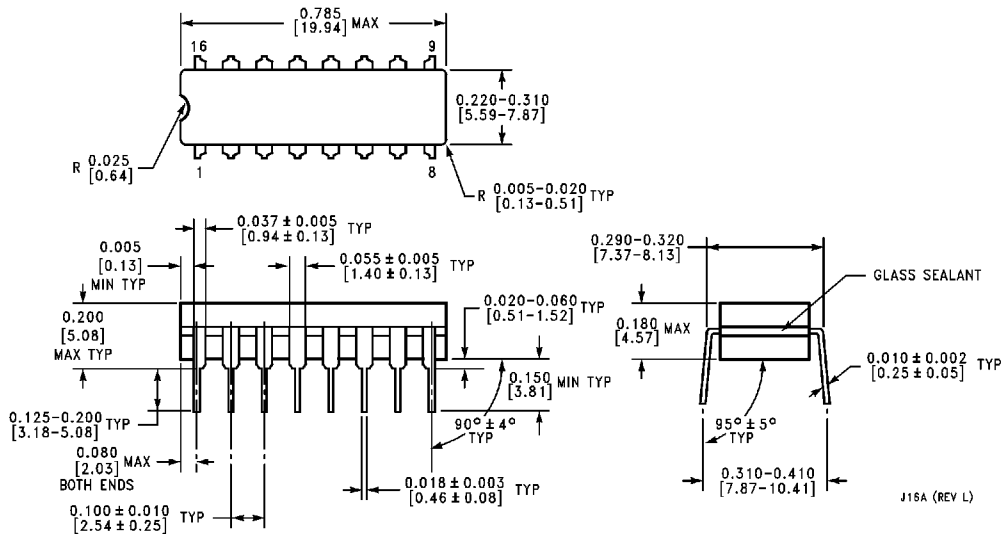

16-Lead Ceramic Dual-In-Line Package (J)
Order Number 54174DMQB, 54175DMQB, DM54174J or DM54175J
NS Package Number J16A

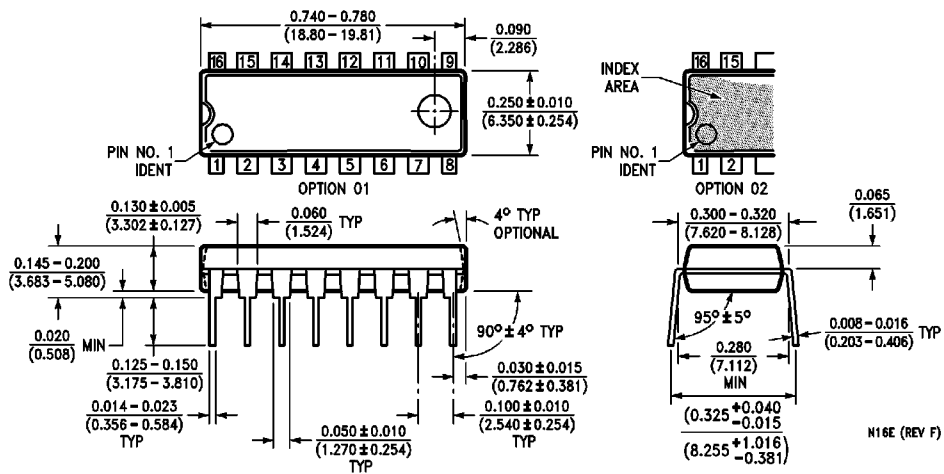

16-Lead Molded Dual-In-Line Package (N)
Order Number DM74174N or DM74175N
NS Package Number N16E

Physical Dimensions inches (millimeters) (Continued)

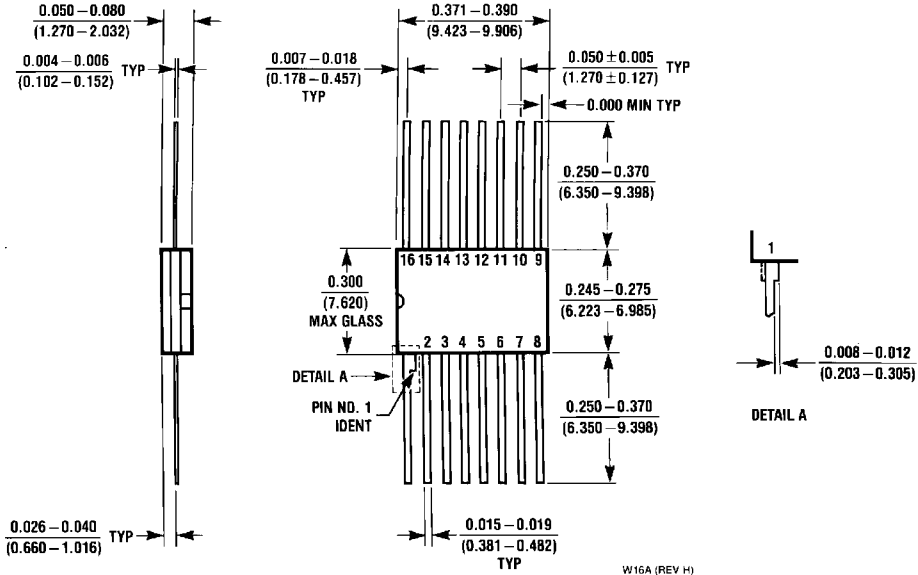

16-Lead Ceramic Flat Package (W)
Order Number 54174FMQB, 54175FMQB, DM54174W or DM54175W
NS Package Number W16A

LIFE SUPPORT POLICY

NATIONAL'S PRODUCTS ARE NOT AUTHORIZED FOR USE AS CRITICAL COMPONENTS IN LIFE SUPPORT DEVICES OR SYSTEMS WITHOUT THE EXPRESS WRITTEN APPROVAL OF THE PRESIDENT OF NATIONAL SEMICONDUCTOR CORPORATION. As used herein:

1. Life support devices or systems are devices or systems which, (a) are intended for surgical implant into the body, or (b) support or sustain life, and whose failure to perform, when properly used in accordance with instructions for use provided in the labeling, can be reasonably expected to result in a significant injury to the user.
2. A critical component is any component of a life support device or system whose failure to perform can be reasonably expected to cause the failure of the life support device or system, or to affect its safety or effectiveness.



National Semiconductor Corporation
 1111 West Bardin Road
 Arlington, TX 76017
 Tel: 1(800) 272-9959
 Fax: 1(800) 737-7018

National Semiconductor Europe
 Fax: (+49) 0-180-530 85 86
 Email: cnijee@tevm2.nsc.com
 Deutsch Tel: (+49) 0-180-530 85 85
 English Tel: (+49) 0-180-532 78 32
 Français Tel: (+49) 0-180-532 93 58
 Italiano Tel: (+49) 0-180-534 16 80

National Semiconductor Hong Kong Ltd.
 13th Floor, Straight Block,
 Ocean Centre, 5 Canton Rd.
 Tsimshatsui, Kowloon
 Hong Kong
 Tel: (852) 2737-1600
 Fax: (852) 2736-9960

National Semiconductor Japan Ltd.
 Tel: 81-043-299-2309
 Fax: 81-043-299-2408

National does not assume any responsibility for use of any circuitry described, no circuit patent licenses are implied and National reserves the right at any time without notice to change said circuitry and specifications.