

NCS2300 Series

Advance Information Low Power Comparators

The NCS2300 Series is an ultra-low power comparator family. These devices consume only 11 μA of supply current. They operate at a wide voltage range of 1.7 V to 12 V. Additional features include no output phase inversion with overdriven inputs, internal hysteresis, which allows for clean output switching, and rail-to-rail input and output performance. The NCS2300 Series is available in the tiny SOT23-5 and SOT23-6 package. There are eight options featuring two industry standard pinouts. (Table 1)

The NCS2301/3 Series in the SOT23-6 package features an enable function, which can be externally controlled. When the enable pin is pulled low (output tri-state mode), current consumption is typically 0.3 μA . This allows the user to implement these devices in power sensitive applications such as portable electronics.

Features

- Rail-to-Rail Input/Output Performance
- Low Supply Current of 11 μA
- No Phase Inversion with Overdriven Input Signals
- Glitchless Transitioning in or out of Tri-state Mode
- Complementary or Open Drain Output Configuration
- Available with the Enable Function
- Internal Hysteresis
- Propagation of Delay of 1.8 μs

Typical Applications

- Cellular Telephones
- Alarm and Security Systems
- Battery Powered Instruments
- Personal Digital Assistants

Table 1. Comparator Selector Guide

Output Type	Device	Package	Pinout Style
Complementary	NCS2300SN1T1	SOT23-5	1
Complementary	NCS2300SN2T1	SOT23-5	2
Complementary, Enable	NCS2301SN1T1	SOT23-6	1
Complementary, Enable	NCS2301SN2T1	SOT23-6	2
Open Drain	NCS2302SN1T1	SOT23-5	1
Open Drain	NCS2302SN2T1	SOT23-5	2
Open Drain, Enable	NCS2303SN1T1	SOT23-6	1
Open Drain, Enable	NCS2303SN2T1	SOT23-6	2

This document contains information on a new product. Specifications and information herein are subject to change without notice.



ON Semiconductor®

<http://onsemi.com>



SOT23-5
(TSOP-5, SC59-5)
SN SUFFIX
CASE 483



SOT23-6
(TSOP-6, SC59-6)
SN SUFFIX
CASE 318G

PIN CONNECTIONS

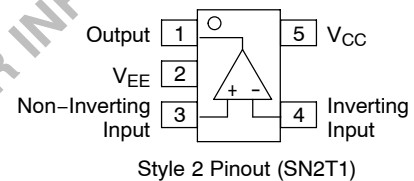
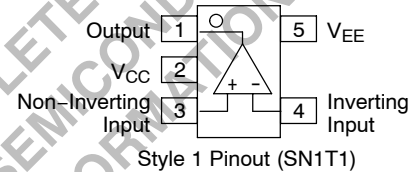

SOT23-5

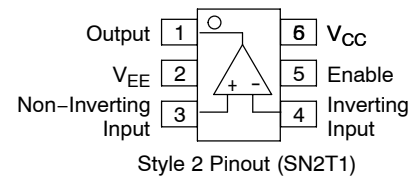
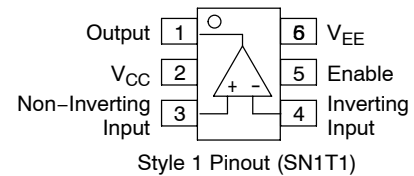

SOT23-6

ORDERING INFORMATION

See detailed ordering and shipping information in the package dimensions section on page 12 of this data sheet.

DEVICE MARKING INFORMATION

See general marking information in the device marking section on page 12 of this data sheet.

NCS2300 Series

MAXIMUM RATINGS

Rating	Symbol	Value	Unit
Supply Voltage Range (V_{CC} to V_{EE})	V_S	12	V
Non-inverting/Inverting Input to V_{EE}	–	–0.1 to ($V_{CC} + 0.1$)	V
Thermal Resistance, Junction to Air	$R_{\theta JA}$	248	°C/W
Operating Junction Temperature	T_J	150	°C
Operating Ambient Temperature	T_A	–40 to +105	°C
Storage Temperature Range	T_{stg}	–65 to +150	°C
Output Short Circuit Duration Time (Note 1)	t_S	Indefinite	s
ESD Tolerance (Note 2) Human Body Model Machine Model	–	1000 120	V

1. The maximum package power dissipation limit must not be exceeded.

$$P_D = \frac{T_{J(max)} - T_A}{R_{\theta JA}}$$

2. ESD data available upon request.

ELECTRICAL CHARACTERISTICS (For all values $V_{CC} = 1.7$ V to 12 V, $V_{EE} = 0$ V, $T_A = 25^\circ\text{C}$, unless otherwise noted.) (Note 3)

Characteristics	Symbol	Min	Typ	Max	Unit
Input Hysteresis $T_A = 25^\circ\text{C}$	V_{HYS}	2.0	7.5	12	mV
Input Offset Voltage $V_{CC} = 1.7$ V $T_A = 25^\circ\text{C}$ $T_A = -40^\circ\text{C}$ to 105°C $V_{CC} = 6.0$ V $T_A = 25^\circ\text{C}$ $T_A = -40^\circ\text{C}$ to 105°C $V_{CC} = 12$ V $T_A = 25^\circ\text{C}$ $T_A = -40^\circ\text{C}$ to 105°C	V_{IO}	–7.0 –9.0 –5.0 –7.0 –5.0 –7.0	0.4 – 0.2 – 0.1 –	+7.0 +9.0 +5.0 +7.0 +5.0 +7.0	mV
Common Mode Voltage Range	V_{CM}	–	V_{EE} to V_{CC}	–	V
Output Leakage Current (NCS2302/2303) $V_{CC} = 12$ V	I_{LEAK}	–	0.2	–	nA
Output Short-Circuit Sourcing or Sinking	I_{SC}	–	170	–	mA
Common Mode Rejection Ratio $V_{CM} = V_{CC}$	CMRR	60	80	–	dB
Input Bias Current	I_{IB}	–	1.0	–	pA
Power Supply Rejection Ratio $\Delta V_S = 5.15$ V	PSRR	60	75	–	dB
Supply Current $V_{CC} = 1.7$ V $T_A = 25^\circ\text{C}$ $T_A = -40^\circ\text{C}$ to 105°C $V_{CC} = 6.0$ V $T_A = 25^\circ\text{C}$ $T_A = -40^\circ\text{C}$ to 105°C $V_{CC} = 12$ V $T_A = 25^\circ\text{C}$ $T_A = -40^\circ\text{C}$ to 105°C	I_{CC}	–	8.0 – 8.0 – 8.0 –	15 15 15 15 15 15	μA

3. The limits over the extended temperature range are guaranteed by design only.

NCS2300 Series

ELECTRICAL CHARACTERISTICS (continued) (For all values $V_{CC} = 1.7\text{ V}$ to 12 V , $V_{EE} = 0\text{ V}$, $T_A = 25^\circ\text{C}$, unless otherwise noted.) (Note 4)

Characteristics	Symbol	Min	Typ	Max	Unit
Output Voltage High (NCS2300/NCS2301) $V_{CC} = 1.7\text{ V}$, $I_{\text{source}} = 0.5\text{ mA}$ $T_A = 25^\circ\text{C}$ $T_A = -40^\circ\text{C}$ to 105°C $V_{CC} = 6.0\text{ V}$, $I_{\text{source}} = 3.0\text{ mA}$ $T_A = 25^\circ\text{C}$ $T_A = -40^\circ\text{C}$ to 105°C $V_{CC} = 12\text{ V}$, $I_{\text{source}} = 5.0\text{ mA}$ $T_A = 25^\circ\text{C}$ $T_A = -40^\circ\text{C}$ to 105°C	V_{OH}	$V_{CC} - 0.075$ $V_{CC} - 0.075$	$V_{CC} - 0.050$ -	-	V
Output Voltage Low $V_{CC} = 1.7\text{ V}$, $I_{\text{sink}} = 0.5\text{ mA}$ $T_A = 25^\circ\text{C}$ $T_A = -40^\circ\text{C}$ to 105°C $V_{CC} = 6.0\text{ V}$, $I_{\text{sink}} = 3.0\text{ mA}$ $T_A = 25^\circ\text{C}$ $T_A = -40^\circ\text{C}$ to 105°C $V_{CC} = 12\text{ V}$, $I_{\text{sink}} = 5.0\text{ mA}$ $T_A = 25^\circ\text{C}$ $T_A = -40^\circ\text{C}$ to 105°C	V_{OL}	-	$V_{EE} + 0.050$ -	$V_{EE} + 0.075$ $V_{EE} + 0.075$	V
Propagation Delay 20 mV Overdrive, $C_L = 15\text{ pF}$	t_{PHL} t_{PLH}	-	1.45 1.75	-	μs
Output Fall Time $V_{CC} = 12\text{ V}$, $C_L = 50\text{ pF}$	t_{FALL}	-	28	-	ns
Output Rise Time $V_{CC} = 12\text{ V}$, $C_L = 50\text{ pF}$	t_{RISE}	-	26	-	ns
Power-up Time	t_{PU}	-	35	-	μs

ENABLE FUNCTION ELECTRICAL CHARACTERISTICS (NCS2301/3 only)

(For all values $V_{CC} = 12\text{ V}$, $V_{EE} = 0\text{ V}$, $T_A = 25^\circ\text{C}$, unless otherwise noted.) (Note 4)

Enable Voltage Threshold Input Voltage Increasing, Device Enabled Input Voltage Decreasing, Device Disabled	$V_{EN(HIGH)}$ $V_{EN(LOW)}$	- 1.2	1.6 1.4	1.7 -	V
Enable Hysteresis	V_{ENHYS}	-	200	-	mV
Enable Pull-up Current	I_{EN}	-	212	300	nA
Disable State Supply Current	I_{CCD}	-	1.5	2.0	μA
Enable Input to Output Propagation Delay Input Voltage Increasing, Device Enabled Input Voltage Decreasing, Device Disabled	$t_{EN(ON)}$ $t_{EN(OFF)}$	- -	106 4.4	- -	μs

4. The limits over the extended temperature range are guaranteed by design only.

NCS2300 Series

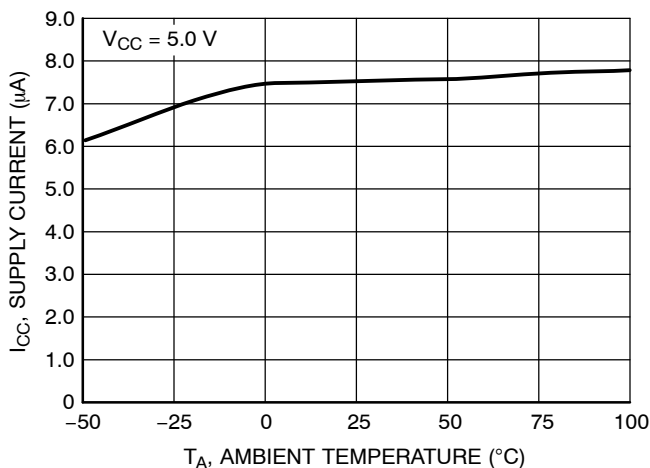

Figure 1. NCS2300 Series Supply Current vs. Temperature

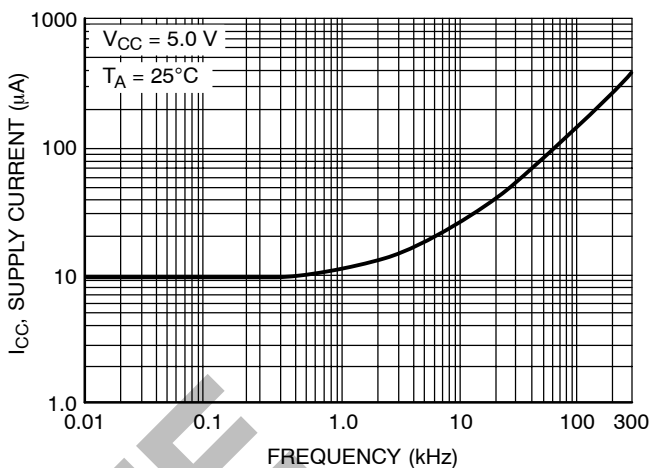

Figure 2. NCS2300 Series Supply Current vs. Output Transition Frequency

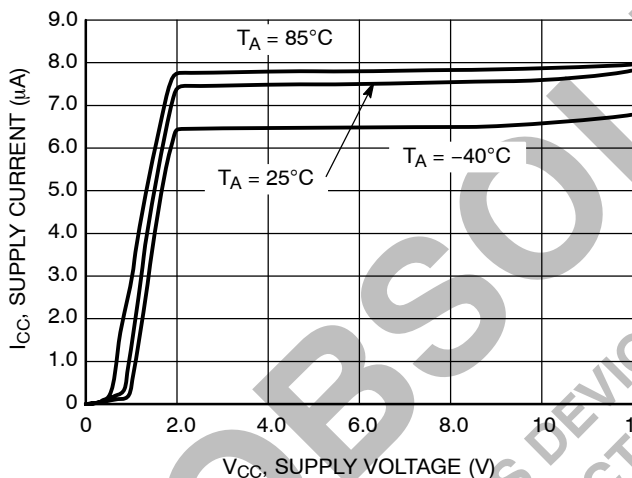

Figure 3. NCS2300 Series Supply Current vs. Supply Voltage

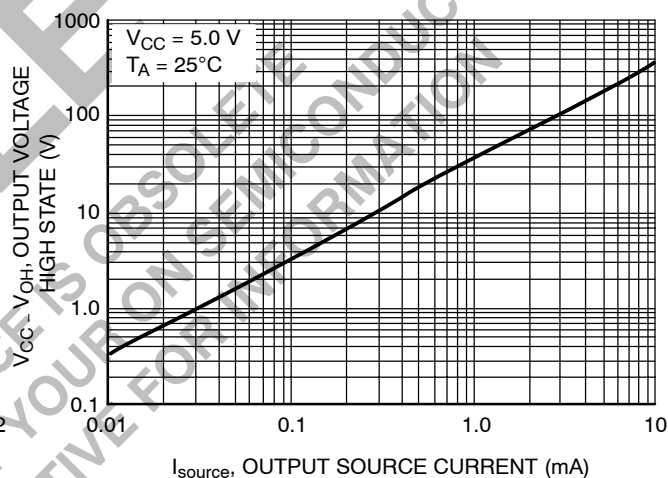

Figure 4. NCS2300/1 Output Voltage High State vs. Output Source Current

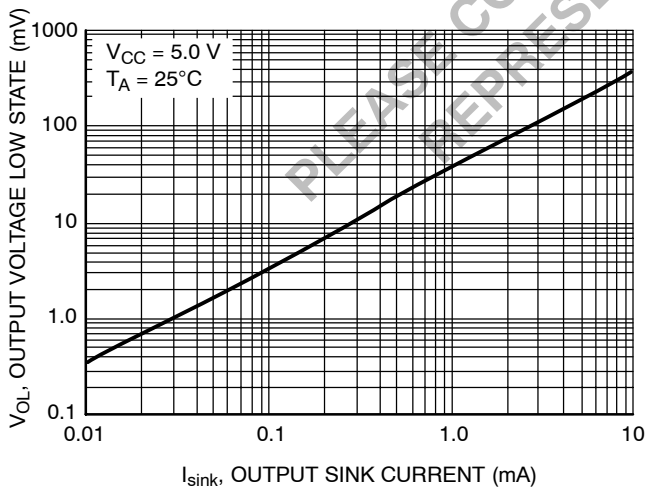

Figure 5. NCS2300 Series Output Voltage Low State vs. Output Sink Current

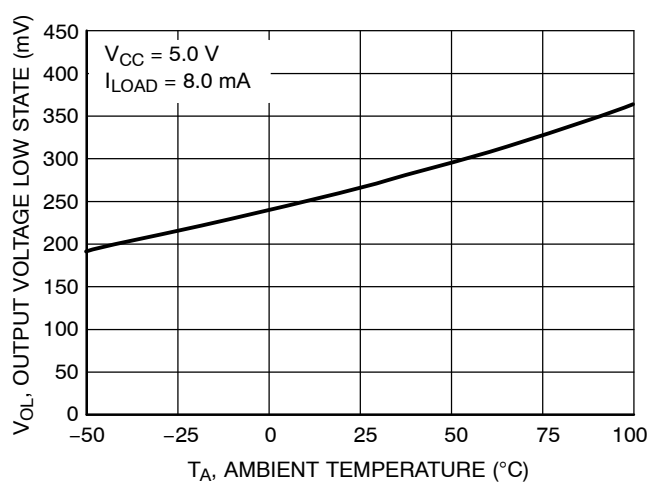

Figure 6. NCS2300 Series Output Voltage Low State vs. Temperature

NCS2300 Series

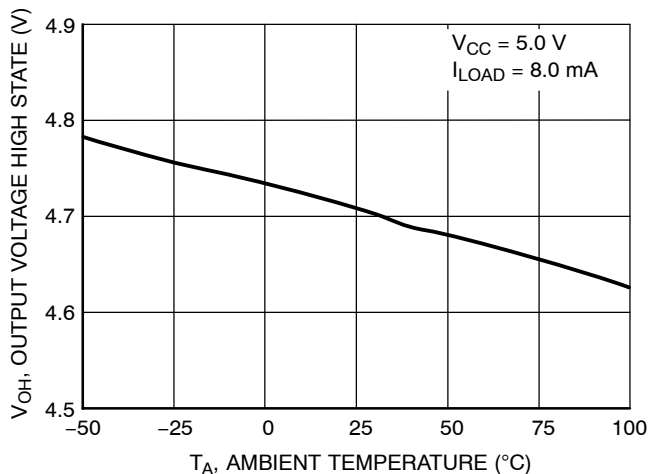

Figure 7. NCS2300/1 Series Output Voltage High State vs. Temperature

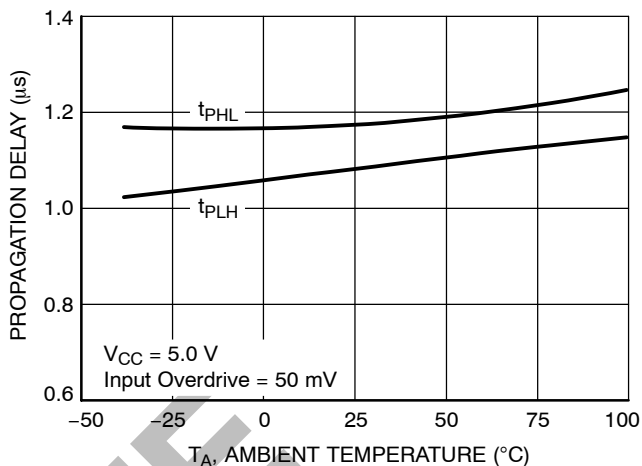

Figure 8. NCS2300 Series Propagation Delay vs. Temperature

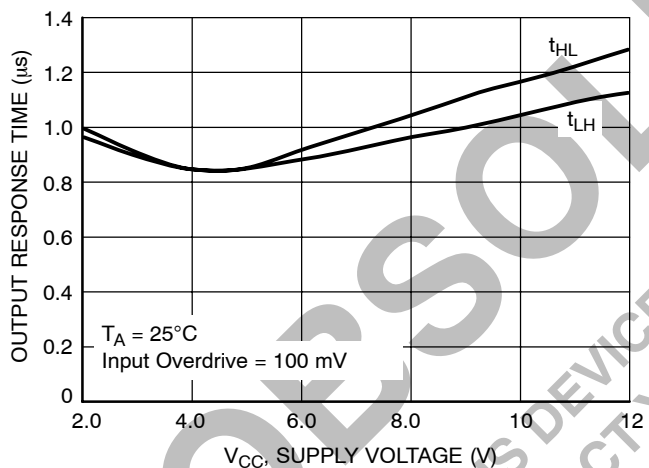

Figure 9. NCS2300 Series Output Response Time vs. Supply Voltage

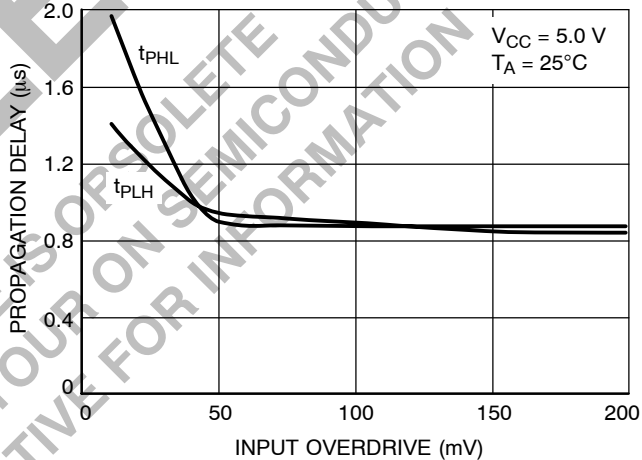

Figure 10. NCS2300 Series Propagation Delay vs. Input Overdrive

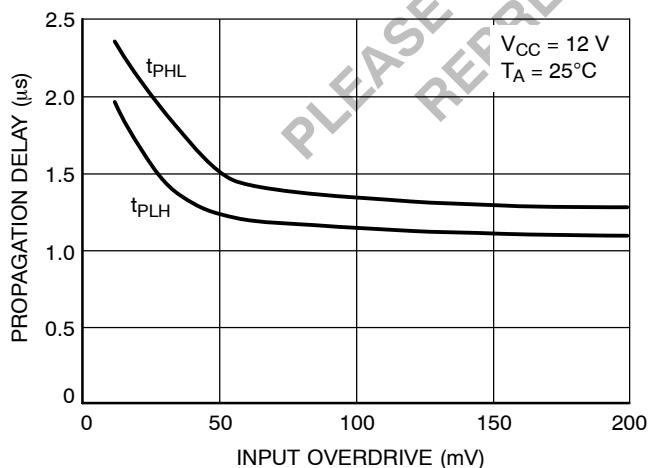

Figure 11. NCS2300 Series Propagation Delay vs. Input Overdrive

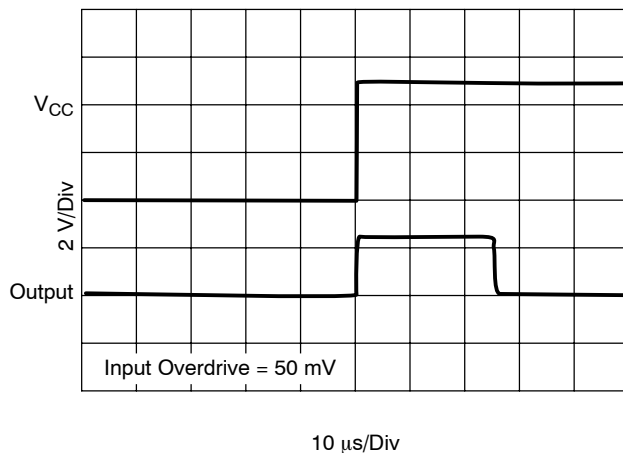

Figure 12. NCS2300 Series Power-Up Delay

NCS2300 Series

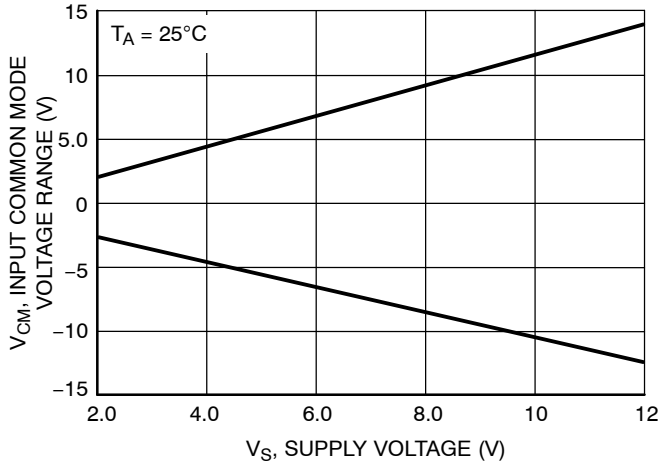

Figure 13. NCS2300 Series Input Common Mode Voltage vs. Supply Voltage

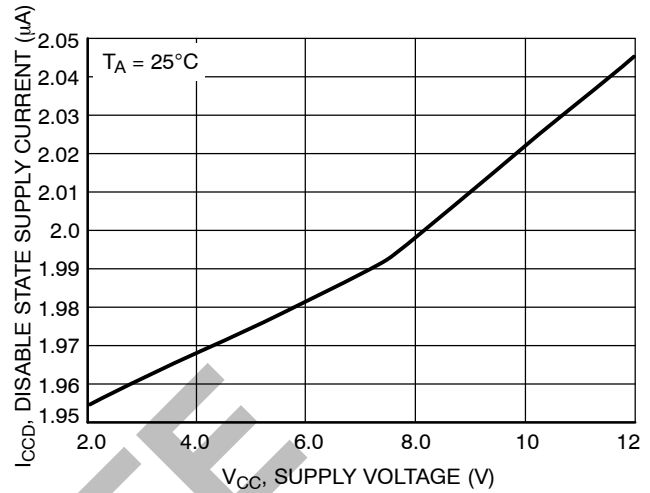

Figure 14. NCS2301/3 Series Disable State Supply Current versus Supply Voltage

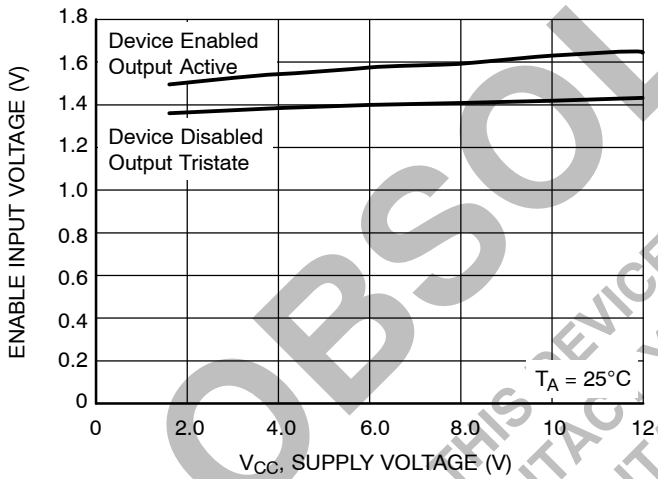

Figure 15. NCS2301/3 Enable Input Voltage versus Supply Voltage

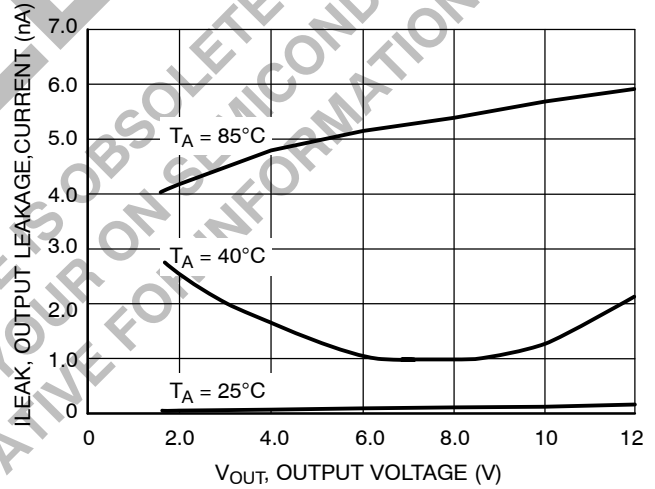

Figure 16. NCS2302/3 Output Leakage Current versus Output Voltage

NCS2300 Series

OPERATING DESCRIPTION

The NCS2300 Series is an ultra-low power comparator family. These devices consume only 11 μA of supply current while achieving a typical propagation delay of 1.8 μs at a 20 mV overdrive. They operate at a wide voltage range of 1.7 V to 12 V. The common-mode input voltage range extends 0.1 V beyond the upper and lower rail without phase inversion or other adverse effects. This series is available in the SOT23-5 and SOT23-6 package.

The SOT23-6 features the enable function, which can be externally controlled. This feature allows significantly lower current consumption of 1.8 μA . This makes the devices suitable for implementation in power sensitive applications such as portable electronics. The enable function is active high when connected to the V_{CC} pin. When the enable pin is driven low (device disabled), output tri-state mode is activated. The device will remain in this mode and will not respond to any changes at the inputs of the

comparator. In order to pull the device out of tri-state mode, the enable upper voltage threshold must be met. Figure 15 shows the enable input voltage required to either enable or disable the device, with a variance in supply voltage. In addition, these devices have a typical internal hysteresis of ± 7.5 mV. This allows for greater noise immunity and clean output switching.

Output Stage

The NCS2300/1 has a complementary P and N channel output stage that has capability of driving a rail-to-rail output swing with a load ranging up to 5.0 mA. It is designed such that shoot-through current is minimized while switching. This feature eliminates the need for bypass capacitors under most circumstances.

The NCS2302/3 has an open drain n-channel output stage that can be pulled up to 12 V (max) with an external resistor. This facilitates mixed voltage system applications.

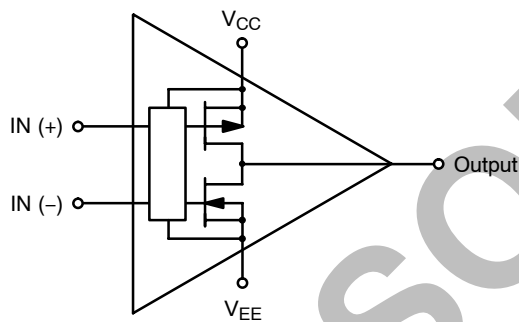

Figure 17. NCS2300/1SNxT1 Complementary Output Configuration

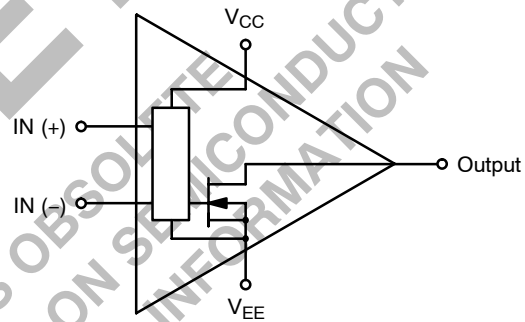
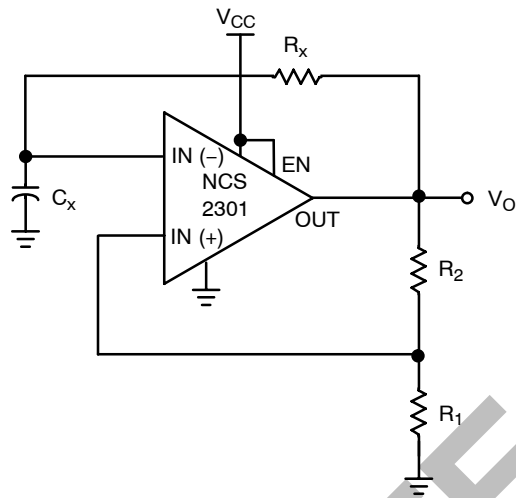

Figure 18. NCS2302/3SNxT1 Open Drain Output Configuration

NCS2300 Series



The oscillation frequency can be programmed as follows:

$$f = \frac{1}{T} = \frac{1}{2.2 R_x C_x}$$

Figure 19. Schmitt Trigger Oscillator

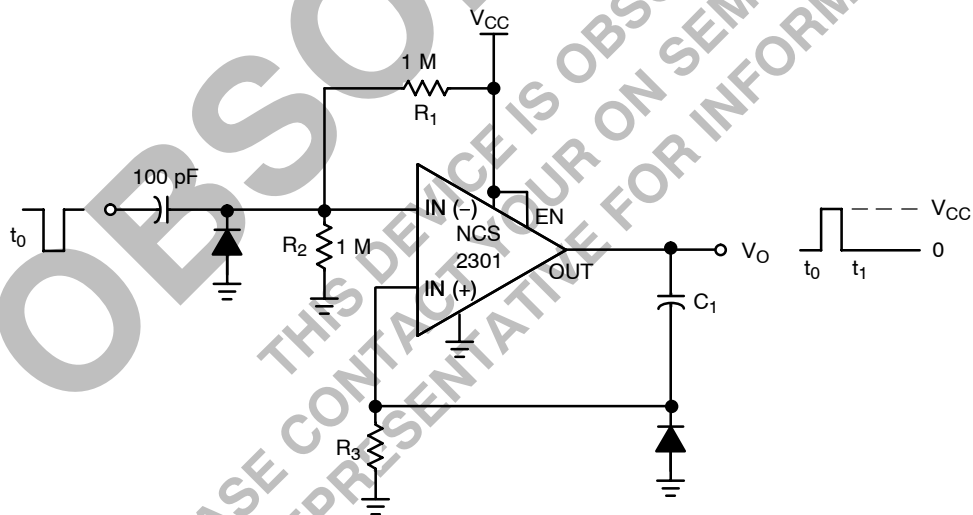

The resistor divider R_1 and R_2 can be used to set the magnitude of the input pulse. The pulse width is set by adjusting C_1 and R_3 .

Figure 20. One-Shot Multivibrator

NCS2300 Series

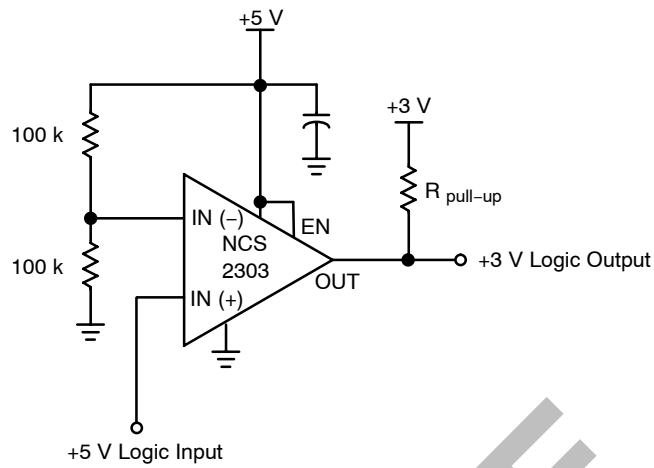

This circuit converts 5 V logic to 3 V logic. Using the NCS2302/3 allows for full 5 V logic swing without creating overvoltage on the 3 V logic input.

Figure 21. Logic Level Translator

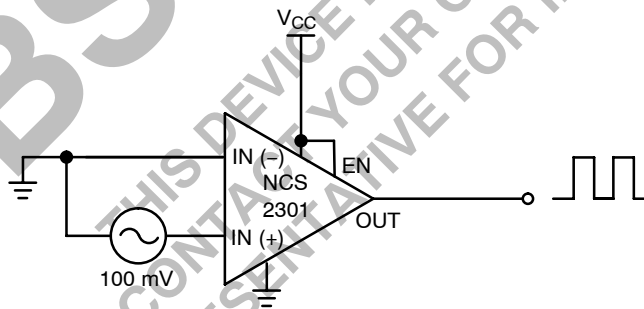

Figure 22. Zero-Crossing Detector

NCS2300 Series

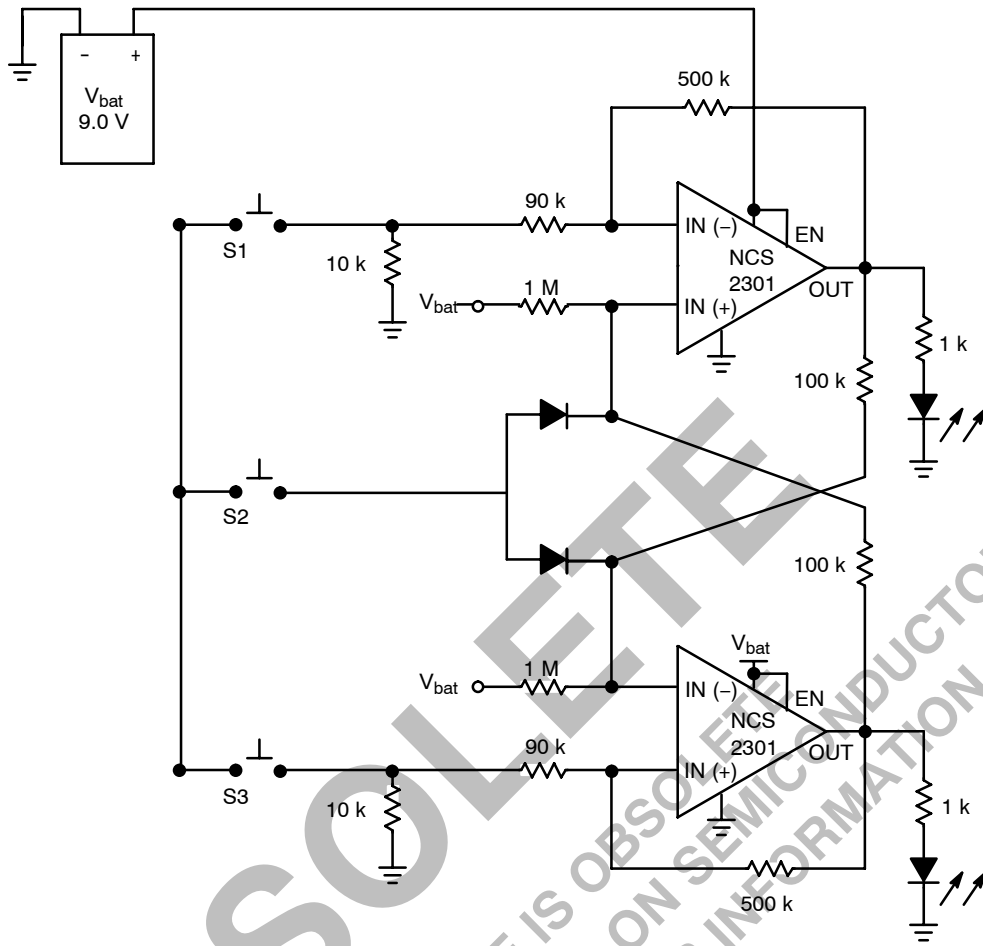

Figure 23. First-Event Detector

NCS2300 Series

MINIMUM RECOMMENDED FOOTPRINT FOR SURFACE MOUNTED APPLICATIONS

Surface mount board layout is a critical portion of the total design. The footprint for the semiconductor packages must be the correct size to insure proper solder connection

interface between the board and the package. With the correct pad geometry, the packages will self align when subjected to a solder reflow process.

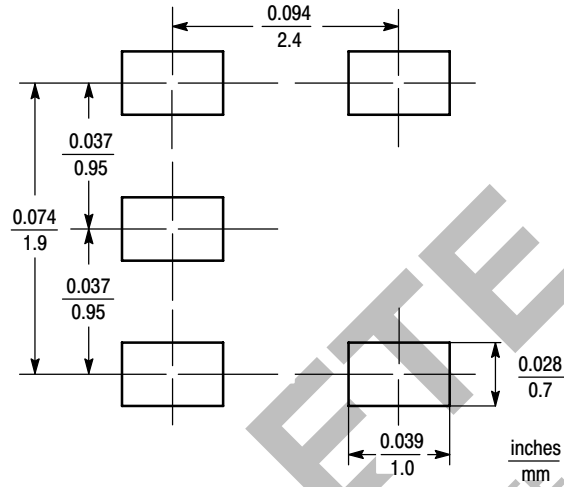

SOT23-5

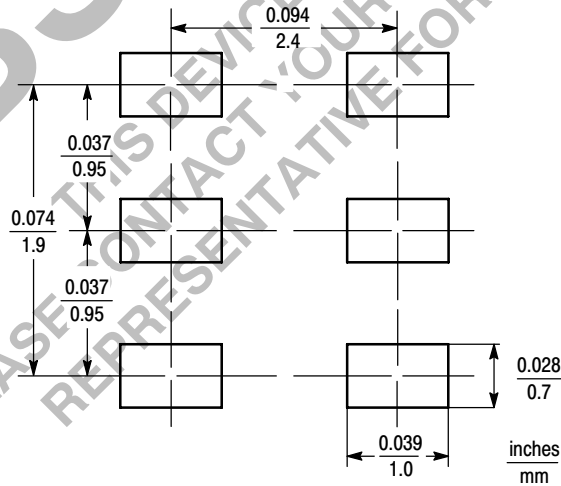

SOT23-6

NCS2300 Series

ORDERING INFORMATION

Device	Pinout Style	Output Type	Package	Shipping
NCS2300SN1T1	1	Complementary	SOT23-5	3000 Tape & Reel
NCS2300SN2T1	2	Complementary	SOT23-5	
NCS2301SN1T1	1	Complementary, Enable	SOT23-6	
NCS2301SN2T1	2	Complementary, Enable	SOT23-6	
NCS2302SN1T1	1	Open Drain	SOT23-5	
NCS2302SN2T1	2	Open Drain	SOT23-5	
NCS2303SN1T1	1	Open Drain, Enable	SOT23-6	
NCS2303SN2T1	2	Open Drain, Enable	SOT23-6	

This device contains 121 active transistors.

PIN CONNECTIONS

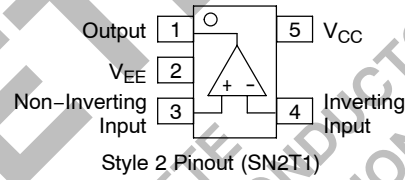
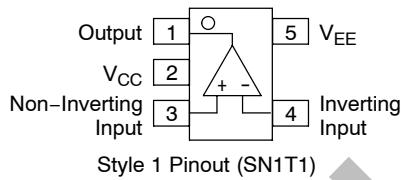

SOT23-5 (NCS2300, NCS2302)

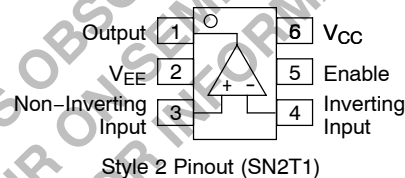
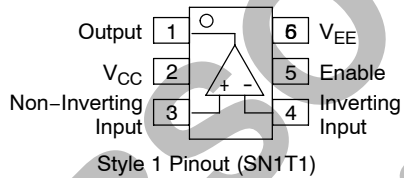

SOT23-6 (NCS2301, NCS2303)

MARKING DIAGRAMS

**SOT23-5
SN SUFFIX
CASE 483**

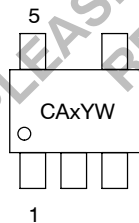

x = A for NCS2300SN1T1
 B for NCS2300SN2T1
 E for NCS2302SN1T1
 F for NCS2302SN2T1
 Y = Year
 W = Work Week

**SOT23-6
SN SUFFIX
CASE 318G**

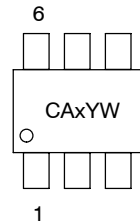

x = C for NCS2301SN1T1
 D for NCS2301SN2T1
 G for NCS2303SN1T1
 H for NCS2303SN2T1
 Y = Year
 W = Work Week

NCS2300 Series

PACKAGE DIMENSIONS

SOT23-5
(TSOP-5, SC59-5)
SN SUFFIX
 PLASTIC PACKAGE
 CASE 483-01
 ISSUE B

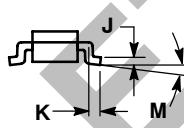
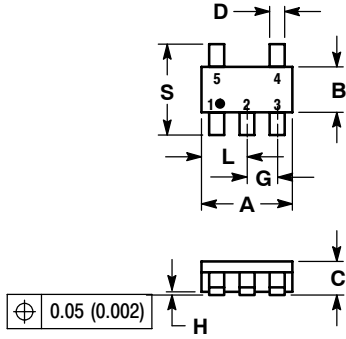

NOTES:

1. DIMENSIONING AND TOLERANCING PER ANSI Y14.5M, 1982.
2. CONTROLLING DIMENSION: MILLIMETER.
3. MAXIMUM LEAD THICKNESS INCLUDES LEAD FINISH THICKNESS. MINIMUM LEAD THICKNESS IS THE MINIMUM THICKNESS OF BASE MATERIAL.

DIM	MILLIMETERS		INCHES	
	MIN	MAX	MIN	MAX
A	2.90	3.10	0.1142	0.1220
B	1.30	1.70	0.0512	0.0669
C	0.90	1.10	0.0354	0.0433
D	0.25	0.50	0.0098	0.0197
G	0.85	1.05	0.0335	0.0413
H	0.013	0.100	0.0005	0.0040
J	0.10	0.26	0.0040	0.0102
K	0.20	0.60	0.0079	0.0236
L	1.25	1.55	0.0493	0.0610
M	0°	10°	0°	10°
S	2.50	3.00	0.0985	0.1181

OBSOLETE

THIS DEVICE IS OBSOLETE
 PLEASE CONTACT YOUR ON SEMICONDUCTOR
 REPRESENTATIVE FOR INFORMATION

NCS2300 Series

PACKAGE DIMENSIONS

SOT23-6
(TSOP-6, SC59-6)
SN SUFFIX
PLASTIC PACKAGE
CASE 318G-02
ISSUE H

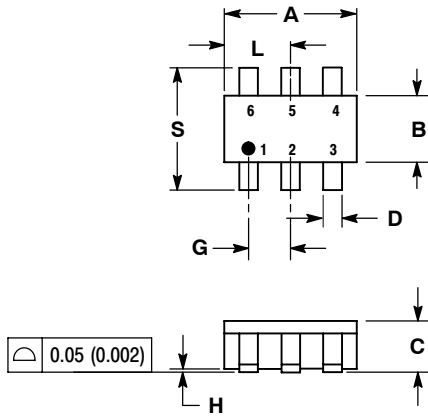

NOTES:

1. DIMENSIONING AND TOLERANCING PER ANSI Y14.5M, 1982.
2. CONTROLLING DIMENSION: MILLIMETER.
3. MAXIMUM LEAD THICKNESS INCLUDES LEAD FINISH THICKNESS. MINIMUM LEAD THICKNESS IS THE MINIMUM THICKNESS OF BASE MATERIAL.

DIM	MILLIMETERS		INCHES	
	MIN	MAX	MIN	MAX
A	2.90	3.10	0.1142	0.1220
B	1.30	1.70	0.0512	0.0669
C	0.90	1.10	0.0354	0.0433
D	0.25	0.50	0.0098	0.0197
G	0.85	1.05	0.0335	0.0413
H	0.013	0.100	0.0005	0.0040
J	0.10	0.26	0.0040	0.0102
K	0.20	0.60	0.0079	0.0236
L	1.25	1.55	0.0493	0.0610
M	0°	10°	0°	10°
S	2.50	3.00	0.0985	0.1181

OBSOLETE

THIS DEVICE IS OBSOLETE
PLEASE CONTACT YOUR ON SEMICONDUCTOR
REPRESENTATIVE FOR INFORMATION

OBSOLETE
THIS DEVICE IS OBSOLETE
PLEASE CONTACT YOUR ON SEMICONDUCTOR
REPRESENTATIVE FOR INFORMATION

ON Semiconductor and **ON** are registered trademarks of Semiconductor Components Industries, LLC (SCILLC). SCILLC reserves the right to make changes without further notice to any products herein. SCILLC makes no warranty, representation or guarantee regarding the suitability of its products for any particular purpose, nor does SCILLC assume any liability arising out of the application or use of any product or circuit, and specifically disclaims any and all liability, including without limitation special, consequential or incidental damages. "Typical" parameters which may be provided in SCILLC data sheets and/or specifications can and do vary in different applications and actual performance may vary over time. All operating parameters, including "Typicals" must be validated for each customer application by customer's technical experts. SCILLC does not convey any license under its patent rights nor the rights of others. SCILLC products are not designed, intended, or authorized for use as components in systems intended for surgical implant into the body, or other applications intended to support or sustain life, or for any other application in which the failure of the SCILLC product could create a situation where personal injury or death may occur. Should Buyer purchase or use SCILLC products for any such unintended or unauthorized application, Buyer shall indemnify and hold SCILLC and its officers, employees, subsidiaries, affiliates, and distributors harmless against all claims, costs, damages, and expenses, and reasonable attorney fees arising out of, directly or indirectly, any claim of personal injury or death associated with such unintended or unauthorized use, even if such claim alleges that SCILLC was negligent regarding the design or manufacture of the part. SCILLC is an Equal Opportunity/Affirmative Action Employer. This literature is subject to all applicable copyright laws and is not for resale in any manner.

PUBLICATION ORDERING INFORMATION

LITERATURE FULFILLMENT:

Literature Distribution Center for ON Semiconductor
P.O. Box 5163, Denver, Colorado 80217 USA
Phone: 303-675-2175 or 800-344-3860 Toll Free USA/Canada
Fax: 303-675-2176 or 800-344-3867 Toll Free USA/Canada
Email: orderlit@onsemi.com

N. American Technical Support: 800-282-9855 Toll Free
USA/Canada
Europe, Middle East and Africa Technical Support:
Phone: 421 33 790 2910
Japan Customer Focus Center
Phone: 81-3-5773-3850

ON Semiconductor Website: www.onsemi.com
Order Literature: <http://www.onsemi.com/orderlit>
For additional information, please contact your local
Sales Representative