

DM74AS04 Hex Inverter

General Description

This device contains six independent gates, each of which performs the logic INVERT function.

- Advanced oxide-isolated, ion-implanted Schottky TTL process
- Functionally and pin for pin compatible with Schottky and low power Schottky TTL counterpart
- Improved AC performance over Schottky and low power Schottky counterparts

Features

- Switching specifications at 50 pF
- Switching specifications guaranteed over full temperature and V_{CC} range

Connection Diagram

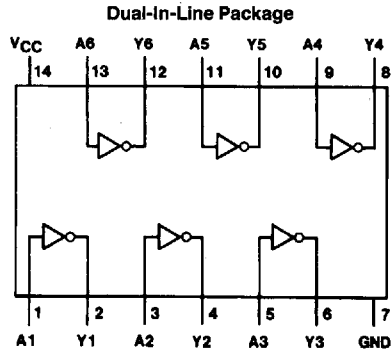

TL/F/6273-1

Order Number DM74AS04M, N, SJ
See NS Package Number M14A, M14D or N14A

Function Table

$$Y = \bar{A}$$

Input A	Output Y
L	H
H	L

H = High Logic Level
L = Low Logic Level

Absolute Maximum Ratings

Supply Voltage	7V
Input Voltage	7V
Operating Free Air Temperature Range	0°C to +70°C
Storage Temperature Range	-65°C to +150°C
Typical θ_{JA}	
N Package	84.5°C/W
M Package	115.0°C/W

Note: The "Absolute Maximum Ratings" are those values beyond which the safety of the device cannot be guaranteed. The device should not be operated at these limits. The parametric values defined in the "Electrical Characteristics" table are not guaranteed at the absolute maximum ratings. The "Recommended Operating Conditions" table will define the conditions for actual device operation.

Recommended Operating Conditions

Symbol	Parameter	Min	Nom	Max	Units
V_{CC}	Supply Voltage	4.5	5	5.5	V
V_{IH}	High Level Input Voltage	2			V
V_{IL}	Low Level Input Voltage			0.8	V
I_{OH}	High Level Output Current			-2	mA
I_{OL}	Low Level Output Current			20	mA
T_A	Free Air Operating Temperature	0		70	°C

Electrical Characteristics

over recommended operating free air temperature range. All typical values are measured at $V_{CC} = 5V$, $T_A = 25^\circ C$.

Symbol	Parameter	Conditions	Min	Typ	Max	Units
V_{IK}	Input Clamp Voltage	$V_{CC} = 4.5V$, $I_I = -18 mA$			-1.2	V
V_{OH}	High Level Output Voltage	$I_{OH} = -2 mA$ $V_{CC} = 4.5V$ to $5.5V$	$V_{CC} - 2$			V
V_{OL}	Low Level Output Voltage	$V_{CC} = 4.5V$ $I_{OL} = 20 mA$		0.35	0.5	V
I_I	Input Current @ Max Input Voltage	$V_{CC} = 5.5V$, $V_{IH} = 7V$			0.1	mA
I_{IH}	High Level Input Current	$V_{CC} = 5.5V$, $V_{IH} = 2.7V$			20	μA
I_{IL}	Low Level Input Current	$V_{CC} = 5.5V$, $V_{IL} = 0.4V$			-0.5	mA
I_O	Output Drive Current	$V_{CC} = 5.5V$, $V_O = 2.25V$	-30		-112	mA
I_{CC}	Supply Current	$V_{CC} = 5.5V$	Outputs High	3	4.8	mA
			Outputs Low	14	26.3	mA

Switching Characteristics

over recommended operating free air temperature range (Note 1)

Symbol	Parameter	Conditions	Min	Max	Units
t_{PLH}	Propagation Delay Time Low to High Level Output	$V_{CC} = 4.5V$ to $5.5V$ $R_L = 500\Omega$ $C_L = 50 pF$	1	5	ns
t_{PHL}	Propagation Delay Time High to Low Level Output		1	4	ns

Note 1: See Section 5 for test waveforms and output load.