

SN54ALS652, SN54ALS653, SN54AS651, SN54AS652 SN74ALS651A, SN74ALS652A, SN74ALS653, SN74ALS654, SN74AS651, SN74AS652 OCTAL BUS TRANSCEIVERS AND REGISTERS WITH 3-STATE OUTPUTS

SDAS068E - DECEMBER 1983 - REVISED JANUARY 1995

- Bus Transceivers/Registers
- Independent Registers and Enables for A and B Buses
- Multiplexed Real-Time and Stored Data
- Choice of True or Inverting Data Paths
- Choice of 3-State or Open-Collector Outputs to A Bus
- Package Options Include Plastic Small-Outline (DW) Packages, Ceramic Chip Carriers (FK), and Standard Plastic (NT) and Ceramic (JT) 300-mil DIPs

DEVICE	A OUTPUT	B OUTPUT	LOGIC
SN74ALS651A, 'AS651	3 State	3 State	Inverting
SN54ALS652, SN74ALS652A, 'AS652	3 State	3 State	True
'ALS653	Open Collector	3 State	Inverting
SN74ALS654	Open Collector	3 State	True

description

These devices consist of bus-transceiver circuits, D-type flip-flops, and control circuitry arranged for multiplexed transmission of data directly from the data bus or from the internal storage registers. Output-enable (OEAB and OEBA) inputs are provided to control the transceiver functions. Select-control (SAB and SBA) inputs are provided to select real-time or stored data transfer. The circuitry used for select control eliminates the typical decoding glitch that occurs in a multiplexer during the transition between stored and real-time data. A low input level selects real-time data, and a high input level selects stored data. Figure 1 illustrates the four fundamental bus-management functions that can be performed with the octal bus transceivers and registers.

Data on the A or B data bus, or both, can be stored in the internal D-type flip-flops by low-to-high transitions at the appropriate clock (CLKAB or CLKBA) terminals regardless of the select- or output-control terminals. When SAB and SBA are in the real-time transfer mode, it is possible to store data without using the internal D-type flip-flops by simultaneously enabling OEAB and OEBA. In this configuration, each output reinforces its input. When all other data sources to the two sets of bus lines are at high impedance, each set of bus lines remains at its last state.

The -1 versions of the SN74ALS651A and SN74ALS652A are identical to the standard versions except that the recommended maximum I_{OL} for the -1 versions is increased to 48 mA. There are no -1 versions of the SN54ALS652, SN54ALS653, SN74ALS653, and SN74ALS654.

The SN54' family is characterized for operation over the full military temperature range of -55°C to 125°C. The SN74' family is characterized for operation from 0°C to 70°C.

SN54ALS', SN54AS' ... JT PACKAGE
SN74ALS', SN74AS' ... DW OR NT PACKAGE
(TOP VIEW)

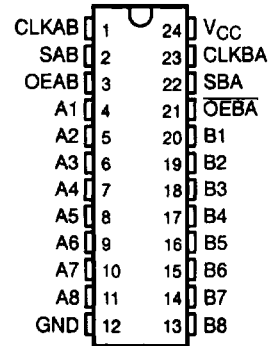

SN54ALS', SN54AS' ... FK PACKAGE
(TOP VIEW)

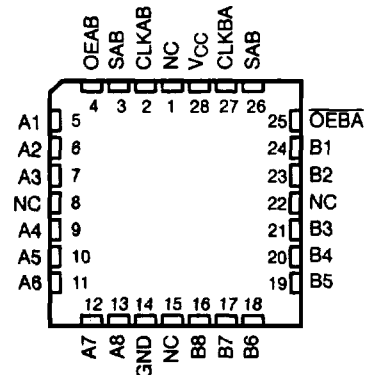

NC - No internal connection

PRODUCTION DATA Information is current as of publication date. Products conform to specifications per the terms of Texas Instruments standard warranty. Production processing does not necessarily include testing of all parameters.

**TEXAS
INSTRUMENTS**

POST OFFICE BOX 655303 • DALLAS, TEXAS 75265

Copyright © 1995, Texas Instruments Incorporated

2-525

**SN54ALS652, SN54ALS653, SN54AS651, SN54AS652
 SN74ALS651A, SN74ALS652A, SN74ALS653, SN74ALS654, SN74AS651, SN74AS652
 OCTAL BUS TRANSCEIVERS AND REGISTERS WITH 3-STATE OUTPUTS**
 SDAS068E - DECEMBER 1983 - REVISED JANUARY 1985

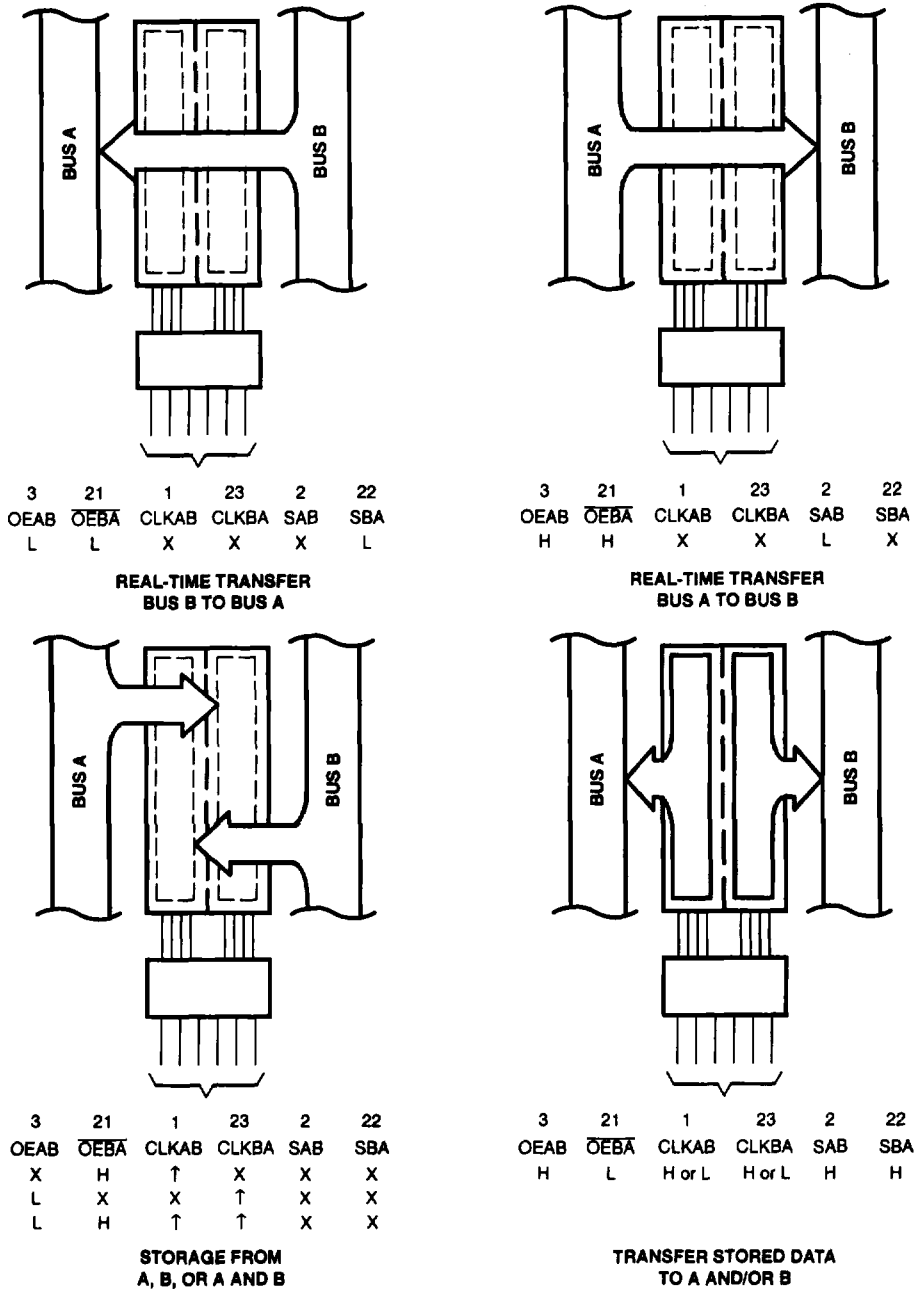

Figure 1. Bus-Management Functions

Pin numbers are for the DW, JT, and NT packages.



POST OFFICE BOX 865303 • DALLAS, TEXAS 75266

SN54ALS652, SN54ALS653, SN54AS651, SN54AS652
SN74ALS651A, SN74ALS652A, SN74ALS653, SN74ALS654, SN74AS651, SN74AS652
OCTAL BUS TRANSCEIVERS AND REGISTERS WITH 3-STATE OUTPUTS

SDAS088E - DECEMBER 1983 - REVISED JANUARY 1995

Function Tables

**SN54ALS653, SN54AS651,
SN74ALS651A, SN74ALS653, SN74AS651**

INPUTS						DATA I/O†		OPERATION OR FUNCTION
OEAB	OEBA	CLKAB	CLKBA	SAB	SBA	A1-A8	B1-B8	
L	H	H or L	H or L	X	X	Input	Input	Isolation
L	H	↑	↑	X	X	Input	Input	Store A and B data
X	H	↑	H or L	X	X	Input	Unspecified‡	Store A, hold B
H	H	↑	↑	X‡	X	Input	Output	Store A in both registers
L	X	H or L	↑	X	X	Unspecified‡	Input	Hold A, store B
L	L	↑	↑	X	X‡	Output	Input	Store B in both registers
L	L	X	X	X	L	Output	Input	Real-time \bar{B} data to A bus
L	L	X	H or L	X	H	Output	Input	Stored \bar{B} data to A bus
H	H	X	X	L	X	Input	Output	Real-time \bar{A} data to B bus
H	H	H or L	X	H	X	Input	Output	Stored \bar{A} data to B bus
H	L	H or L	H or L	H	H	Output	Output	Stored \bar{A} data to B bus and stored \bar{B} data to A bus

† The data output functions may be enabled or disabled by a variety of level combinations at OEAB or OEBA. Data input functions are always enabled; i.e., data at the bus terminals is stored on every low-to-high transition on the clock inputs.

‡ Select control = L; clocks can occur simultaneously.

Select control = H; clocks must be staggered in order to load both registers.

**SN54ALS652, SN54AS652,
SN74ALS652A, SN74ALS654, SN74AS652**

INPUTS						DATA I/O†		OPERATION OR FUNCTION
OEAB	OEBA	CLKAB	CLKBA	SAB	SBA	A1-A8	B1-B8	
L	H	H or L	H or L	X	X	Input	Input	Isolation
L	H	↑	↑	X	X	Input	Input	Store A and B data
X	H	↑	H or L	X	X	Input	Unspecified‡	Store A, hold B
H	H	↑	↑	X‡	X	Input	Output	Store A in both registers
L	X	H or L	↑	X	X	Unspecified‡	Input	Hold A, store B
L	L	↑	↑	X	X‡	Output	Input	Store B in both registers
L	L	X	X	X	L	Output	Input	Real-time B data to A bus
L	L	X	H or L	X	H	Output	Input	Stored B data to A bus
H	H	X	X	L	X	Input	Output	Real-time A data to B bus
H	H	H or L	X	H	X	Input	Output	Stored A data to B bus
H	L	H or L	H or L	H	H	Output	Output	Stored A data to B bus and stored B data to A bus

† The data output functions may be enabled or disabled by a variety of level combinations at OEAB or OEBA. Data input functions are always enabled; i.e., data at the bus terminals is stored on every low-to-high transition on the clock inputs.

‡ Select control = L; clocks can occur simultaneously.

Select control = H; clocks must be staggered in order to load both registers.



SN54ALS652, SN54ALS653, SN54AS651, SN54AS652
SN74ALS651A, SN74ALS652A, SN74ALS653, SN74ALS654, SN74AS651, SN74AS652
OCTAL BUS TRANSCEIVERS AND REGISTERS WITH 3-STATE OUTPUTS

SDAS068E - DECEMBER 1983 - REVISED JANUARY 1985

logic symbols†

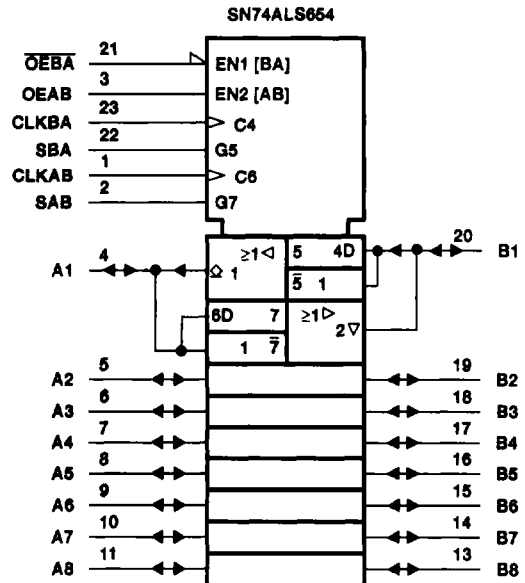
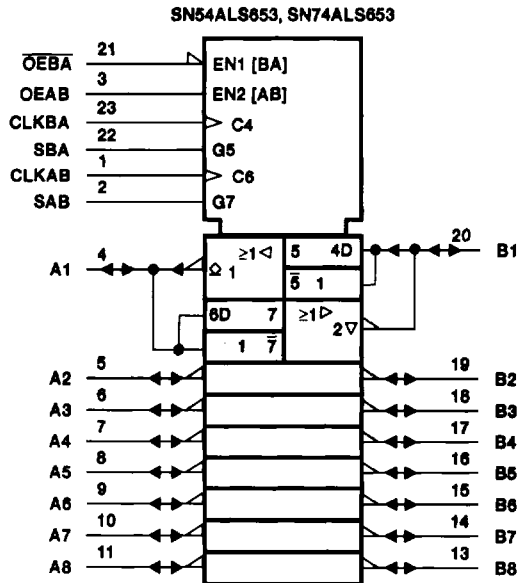
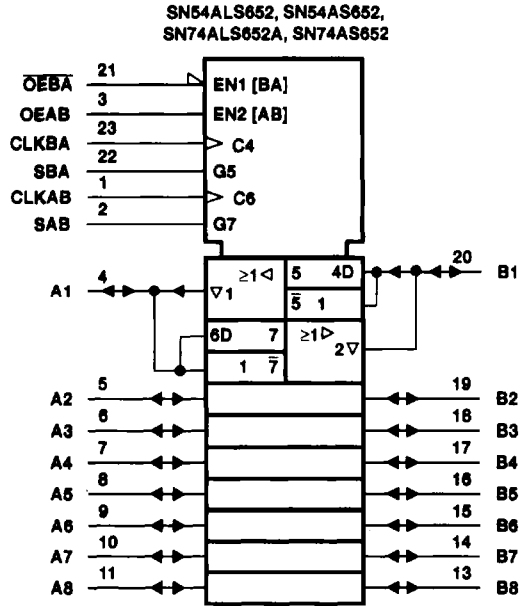
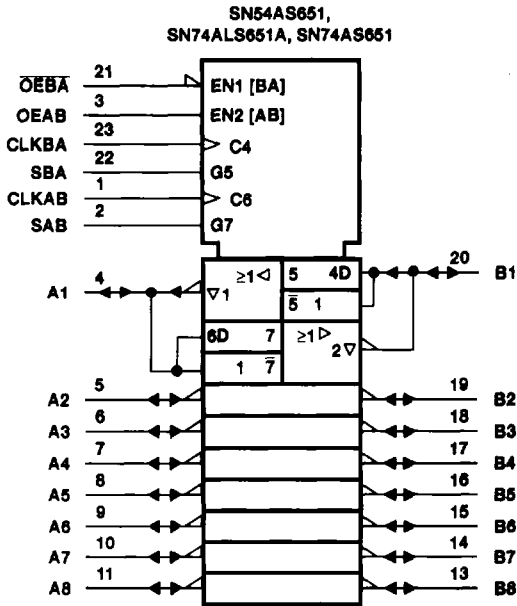

† These symbols are in accordance with ANSI/IEEE Std 91-1984 and IEC Publication 617-12. Pin numbers shown are for the DW, JT, and NT packages.



POST OFFICE BOX 655303 • DALLAS, TEXAS 75265

**SN54ALS652, SN54ALS653, SN54AS651, SN54AS652
SN74ALS651A, SN74ALS652A, SN74ALS653, SN74ALS654, SN74AS651, SN74AS652**
OCTAL BUS TRANSCEIVERS AND REGISTERS WITH 3-STATE OUTPUTS

SDAS068E - DECEMBER 1983 - REVISED JANUARY 1995

logic diagrams (positive logic)

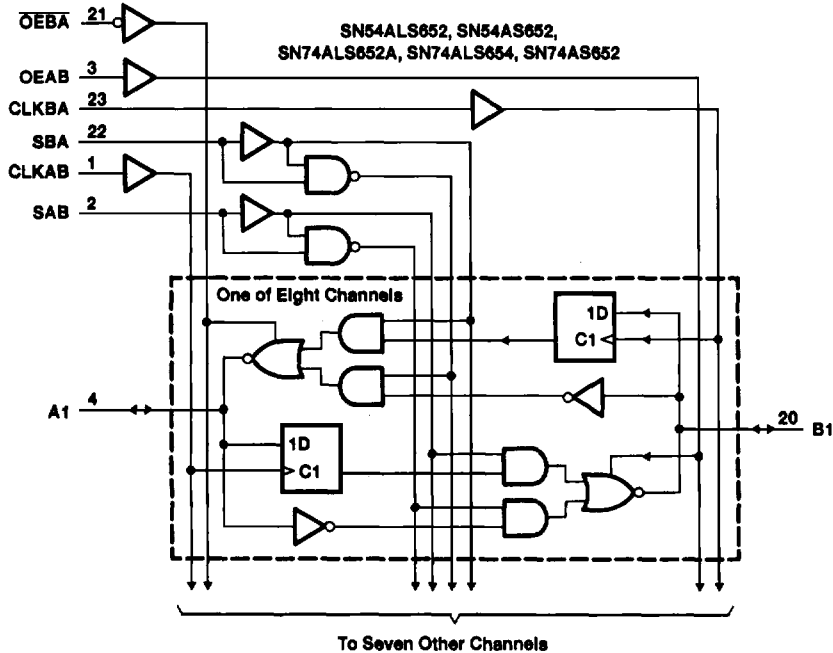
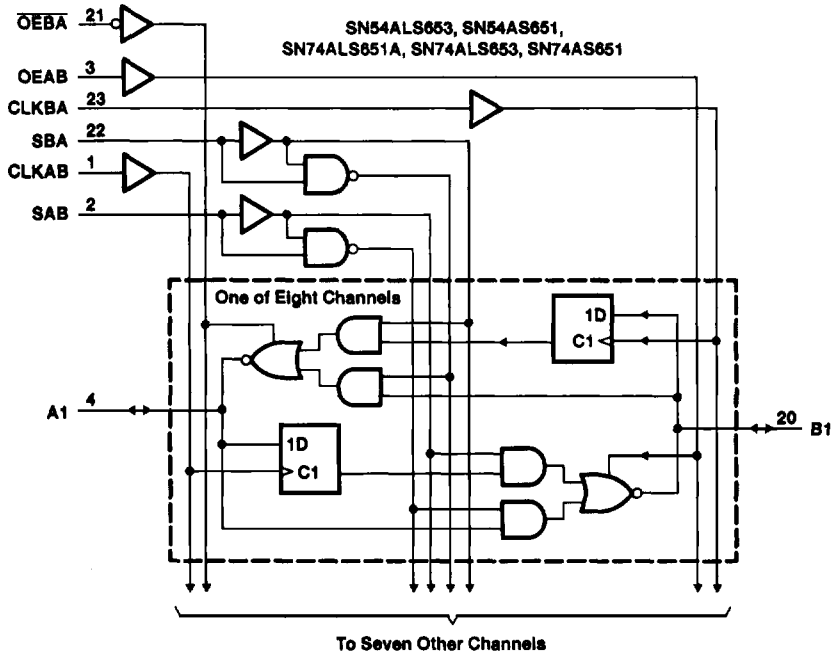

Pin numbers shown are for the DW, JT, and NT packages.



POST OFFICE BOX 655303 • DALLAS, TEXAS 75285

SN54ALS652, SN54ALS653, SN54AS651, SN54AS652
SN74ALS651A, SN74ALS652A, SN74ALS653, SN74ALS654, SN74AS651, SN74AS652
OCTAL BUS TRANSCEIVERS AND REGISTERS WITH 3-STATE OUTPUTS

SDAS068E - DECEMBER 1983 - REVISED JANUARY 1995

absolute maximum ratings over operating free-air temperature range (unless otherwise noted)†

Supply voltage, V_{CC}	7 V
Input voltage, V_I : Control inputs	7 V
I/O ports	5.5 V
Operating free-air temperature range, T_A : SN54ALS652	-55°C to 125°C
SN74ALS651A, SN74ALS652A	0°C to 70°C
Storage temperature range	-65°C to 150°C

† Stresses beyond those listed under "absolute maximum ratings" may cause permanent damage to the device. These are stress ratings only, and functional operation of the device at these or any other conditions beyond those indicated under "recommended operating conditions" is not implied. Exposure to absolute-maximum-rated conditions for extended periods may affect device reliability.

recommended operating conditions

		SN74ALS651A			UNIT	
		MIN	NOM	MAX		
V_{CC}	Supply voltage	4.5	5	5.5	V	
V_{IH}	High-level input voltage	2			V	
V_{IL}	Low-level input voltage			0.8	V	
I_{OH}	High-level output current			-15	mA	
I_{OL}	Low-level output current			24	mA	
				48‡		
f_{clock}	Clock frequency	0		40	MHz	
t_w	Pulse duration	CLKBA or CLKAB high		12.5	ns	
		CLKBA or CLKAB low		12.5		
t_{su}	Setup time before CLKAB↑ or CLKBA↑	A or B		10	ns	
t_h	Hold time after CLKAB↑ or CLKBA↑	A or B		0	ns	
T_A	Operating free-air temperature			0	70	°C

‡ Applies only for the SN74ALS651A-1 and only if V_{CC} is maintained between 4.75 V and 5.25 V

recommended operating conditions

		SN54ALS652			SN74ALS652A			UNIT	
		MIN	NOM	MAX	MIN	NOM	MAX		
V_{CC}	Supply voltage	4.5	5	5.5	4.5	5	5.5	V	
V_{IH}	High-level input voltage	2			2			V	
V_{IL}	Low-level input voltage			0.7			0.8	V	
I_{OH}	High-level output current			-12			-15	mA	
I_{OL}	Low-level output current			12			24	mA	
							48‡		
f_{clock}	Clock frequency	0		36	0		40	MHz	
t_w	Pulse duration	CLKBA or CLKAB high		14.5			12.5	ns	
		CLKBA or CLKAB low		14.5			12.5		
t_{su}	Setup time before CLKAB↑ or CLKBA↑	A or B		15			10	ns	
t_h	Hold time after CLKAB↑ or CLKBA↑	A or B		5			0	ns	
T_A	Operating free-air temperature			-55	125		0	70	°C

‡ Applies only for the SN74ALS652A-1 and only if V_{CC} is maintained between 4.75 V and 5.25 V



SN54ALS652, SN54ALS653, SN54AS651, SN54AS652
SN74ALS651A, SN74ALS652A, SN74ALS653, SN74ALS654, SN74AS651, SN74AS652
OCTAL BUS TRANSCEIVERS AND REGISTERS WITH 3-STATE OUTPUTS

SDAS068E - DECEMBER 1983 - REVISED JANUARY 1995

electrical characteristics over recommended operating free-air temperature range (unless otherwise noted)

PARAMETER	TEST CONDITIONS	SN74ALS651A		UNIT	
		MIN	TYP†		MAX
V_{IK}	$V_{CC} = 4.5 \text{ V}$, $I_I = -18 \text{ mA}$			-1.2	V
V_{OH}	$V_{CC} = 4.5 \text{ V to } 5.5 \text{ V}$, $I_{OH} = -0.4 \text{ mA}$	$V_{CC}-2$			V
	$V_{CC} = 4.5 \text{ V}$	$I_{OH} = -3 \text{ mA}$	2.4	3.2	
V_{OL}	$V_{CC} = 4.5 \text{ V}$	$I_{OH} = -15 \text{ mA}$	2		V
		$I_{OL} = 12 \text{ mA}$	0.25	0.4	
	$I_{OL} = 24 \text{ mA}$	0.35	0.5		
I_I	Control inputs	$V_{CC} = 5.5 \text{ V}$, $V_I = 7 \text{ V}$			mA
	A or B ports	$V_{CC} = 5.5 \text{ V}$, $V_I = 5.5 \text{ V}$			
I_{IH}	Control inputs	$V_{CC} = 5.5 \text{ V}$, $V_I = 2.7 \text{ V}$			μA
	A or B ports‡				
I_{IL}	Control inputs	$V_{CC} = 5.5 \text{ V}$, $V_I = 0.4 \text{ V}$			mA
	A or B ports‡				
$I_{O\S}$	$V_{CC} = 5.5 \text{ V}$, $V_O = 2.25 \text{ V}$	-30		-112	mA
I_{CC}	$V_{CC} = 5.5 \text{ V}$	Outputs high	42	68	mA
		Outputs low	52	82	
		Outputs disabled	52	82	

† All typical values are at $V_{CC} = 5 \text{ V}$, $T_A = 25^\circ\text{C}$.

‡ For I/O ports, the parameters I_{IH} and I_{IL} include the off-state output current.

§ The output conditions have been chosen to produce a current that closely approximates one half of the true short-circuit output current, I_{OS} .



**SN54ALS652, SN54ALS653, SN54AS651, SN54AS652
 SN74ALS651A, SN74ALS652A, SN74ALS653, SN74ALS654, SN74AS651, SN74AS652
 OCTAL BUS TRANSCEIVERS AND REGISTERS WITH 3-STATE OUTPUTS**
 SDAS066E - DECEMBER 1983 - REVISED JANUARY 1985

electrical characteristics over recommended operating free-air temperature range (unless otherwise noted)

PARAMETER	TEST CONDITIONS	SN54ALS652		SN74ALS652A		UNIT		
		MIN	TYP†	MAX	MIN		TYP†	MAX
V_{IK}	$V_{CC} = 4.5 \text{ V}$, $I_I = -18 \text{ mA}$			-1.2		-1.2	V	
V_{OH}	$V_{CC} = 4.5 \text{ V to } 5.5 \text{ V}$, $I_{OH} = -0.4 \text{ mA}$	$V_{CC}-2$		$V_{CC}-2$		V		
	$V_{CC} = 4.5 \text{ V}$	$I_{OH} = -3 \text{ mA}$	2.4	3.2	2.4		3.2	
		$I_{OH} = -12 \text{ mA}$	2					
					2			
V_{OL}	$V_{CC} = 4.5 \text{ V}$	$I_{OL} = 12 \text{ mA}$	0.25	0.4	0.25	0.4	V	
		$I_{OL} = 24 \text{ mA}$			0.35	0.5		
	$V_{CC} = 4.75 \text{ V}$, $I_{OL} = 48 \text{ mA}$ (-1 versions)			0.35	0.5			
I_I	Control inputs	$V_{CC} = 5.5 \text{ V}$, $V_I = 7 \text{ V}$		0.1		0.1	mA	
	A or B ports	$V_{CC} = 5.5 \text{ V}$, $V_I = 5.5 \text{ V}$		0.1		0.1		
I_{IH}	Control inputs	$V_{CC} = 5.5 \text{ V}$, $V_I = 2.7 \text{ V}$		20		20	μA	
	A or B ports‡			20		20		
I_{IL}	Control inputs	$V_{CC} = 5.5 \text{ V}$, $V_I = 0.4 \text{ V}$		-0.2		-0.2	mA	
	A or B ports‡			-0.2		-0.2		
$I_{O§}$	$V_{CC} = 5.5 \text{ V}$, $V_O = 2.25 \text{ V}$	-20		-112	-30		-112	mA
I_{CC}	$V_{CC} = 5.5 \text{ V}$	Outputs high	47	76	47	76	mA	
		Outputs low	55	88	55	88		
		Outputs disabled	55	88	55	88		

† All typical values are at $V_{CC} = 5 \text{ V}$, $T_A = 25^\circ\text{C}$.

‡ For I/O ports, the parameters I_{IH} and I_{IL} include the off-state output current.

§ The output conditions have been chosen to produce a current that closely approximates one half of the true short-circuit output current, I_{OS} .



**SN54ALS652, SN54ALS653, SN54AS651, SN54AS652
SN74ALS651A, SN74ALS652A, SN74ALS653, SN74ALS654, SN74AS651, SN74AS652
OCTAL BUS TRANSCEIVERS AND REGISTERS WITH 3-STATE OUTPUTS**

SDAS066E - DECEMBER 1983 - REVISED JANUARY 1995

switching characteristics (see Figure 2)

PARAMETER	FROM (INPUT)	TO (OUTPUT)	V _{CC} = 4.5 V to 5.5 V, C _L = 50 pF, R ₁ = 500 Ω, R ₂ = 500 Ω, T _A = MIN to MAX†		UNIT
			SN74ALS651A		
			MIN	MAX	
f _{max}			40		MHz
t _{PLH}	CLKBA or CLKAB	A or B	8	32	ns
t _{PHL}			5	17	
t _{PLH}	A or B	B or A	2	18	ns
t _{PHL}			2	10	
t _{PLH}	SBA or SAB‡ (with A or B high)	A or B	8	38	ns
t _{PHL}			6	21	
t _{PLH}	SBA or SAB‡ (with A or B low)	A or B	8	25	ns
t _{PHL}			7	21	
t _{PZH}	OEBA	A	3	20	ns
t _{PZL}			5	18	
t _{PHZ}	OEBA	A	2	9	ns
t _{PLZ}			3	12	
t _{PZH}	OEAB	B	3	22	ns
t _{PZL}			6	21	
t _{PHZ}	OEAB	B	2	12	ns
t _{PLZ}			2	14	

† For conditions shown MIN or MAX, use the appropriate value specified under recommended operating conditions.

‡ These parameters are measured with the internal output state of the storage register opposite that of the bus input.



**SN54ALS652, SN54ALS653, SN54AS651, SN54AS652
SN74ALS651A, SN74ALS652A, SN74ALS653, SN74ALS654, SN74AS651, SN74AS652
OCTAL BUS TRANSCEIVERS AND REGISTERS WITH 3-STATE OUTPUTS**

SDAS066E - DECEMBER 1983 - REVISED JANUARY 1985

switching characteristics (see Figure 2)

PARAMETER	FROM (INPUT)	TO (OUTPUT)	VCC = 4.5 V to 5.5 V, CL = 50 pF, R1 = 500 Ω, R2 = 500 Ω, TA = MIN to MAX†				UNIT
			SN54ALS652		SN74ALS652A		
			MIN	MAX	MIN	MAX	
t _{max}			35		40	MHz	
t _{PLH}	CLKBA or CLKAB	A or B	10	35	8	30	ns
t _{PHL}			5	20	5	17	
t _{PLH}	A or B	B or A	5	20	4	18	ns
t _{PHL}			3	15	3	12	
t _{PLH}	SBA or SAB‡ (with A or B high)	A or B	15	40	8	35	ns
t _{PHL}			6	23	6	20	
t _{PLH}	SBA or SAB‡ (with A or B low)	A or B	8	30	8	25	ns
t _{PHL}			5	24	5	20	
t _{PZH}	OEBA	A	3	20	3	17	ns
t _{PZL}			5	22	5	18	
t _{PHZ}	OEBA	A	1	12	1	10	ns
t _{PLZ}			2	20	2	16	
t _{PZH}	OEAB	B	8	25	3	22	ns
t _{PZL}			6	21	5	18	
t _{PHZ}	OEAB	B	1	12	1	10	ns
t _{PLZ}			2	21	2	16	

† For conditions shown MIN or MAX, use the appropriate value specified under recommended operating conditions.

‡ These parameters are measured with the internal output state of the storage register opposite that of the bus input.



**SN54ALS652, SN54ALS653, SN54AS651, SN54AS652
SN74ALS651A, SN74ALS652A, SN74ALS653, SN74ALS654, SN74AS651, SN74AS652
OCTAL BUS TRANSCEIVERS AND REGISTERS WITH 3-STATE OUTPUTS**

SDAS066E - DECEMBER 1983 - REVISED JANUARY 1995

absolute maximum ratings over operating free-air temperature range (unless otherwise noted)[†]

Supply voltage, V_{CC}	7 V
Input voltage, V_I : All inputs and A I/O ports	7 V
B I/O ports	5.5 V
Operating free-air temperature range, T_A : SN54ALS653	-55°C to 125°C
SN74ALS653, SN74ALS654	0°C to 70°C
Storage temperature range	-65°C to 150°C

[†] Stresses beyond those listed under "absolute maximum ratings" may cause permanent damage to the device. These are stress ratings only, and functional operation of the device at these or any other conditions beyond those indicated under "recommended operating conditions" is not implied. Exposure to absolute-maximum-rated conditions for extended periods may affect device reliability.

recommended operating conditions

		SN54ALS653			SN74ALS653			UNIT
		MIN	NOM	MAX	MIN	NOM	MAX	
V_{CC}	Supply voltage	4.5	5	5.5	4.5	5	5.5	V
V_{IH}	High-level input voltage	2			2			V
V_{IL}	Low-level input voltage			0.7			0.8	V
V_{OH}	High-level output voltage			5.5			5.5	V
I_{OH}	High-level output current			-12			-15	mA
I_{OL}	Low-level output current			12			24	mA
f_{clock}	Clock frequency	0		25	0		35	MHz
t_w	Pulse duration							ns
				CLKBA or CLKAB high			14.5	
				CLKBA or CLKAB low			14.5	
t_{su}	Setup time before CLKAB \uparrow or CLKBA \uparrow			A or B			15	ns
t_h	Hold time after CLKAB \uparrow or CLKBA \uparrow			A or B			5	ns
T_A	Operating free-air temperature	-55		125	0		70	°C

recommended operating conditions

		SN74ALS654			UNIT
		MIN	NOM	MAX	
V_{CC}	Supply voltage	4.5	5	5.5	V
V_{IH}	High-level input voltage	2			V
V_{IL}	Low-level input voltage			0.8	V
V_{OH}	High-level output voltage			5.5	V
I_{OH}	High-level output current			-15	mA
I_{OL}	Low-level output current			24	mA
f_{clock}	Clock frequency	0		35	MHz
t_w	Pulse duration				ns
				CLKBA or CLKAB high	
				CLKBA or CLKAB low	
t_{su}	Setup time before CLKAB \uparrow or CLKBA \uparrow			A or B	ns
t_h	Hold time after CLKAB \uparrow or CLKBA \uparrow			A or B	ns
T_A	Operating free-air temperature	0		70	°C



**SN54ALS652, SN54ALS653, SN54AS651, SN54AS652
 SN74ALS651A, SN74ALS652A, SN74ALS653, SN74ALS654, SN74AS651, SN74AS652
 OCTAL BUS TRANSCEIVERS AND REGISTERS WITH 3-STATE OUTPUTS**

SDAS066E - DECEMBER 1983 - REVISED JANUARY 1985

electrical characteristics over recommended operating free-air temperature range (unless otherwise noted)

PARAMETER		TEST CONDITIONS	SN54ALS653			SN74ALS653			UNIT
			MIN	TYP†	MAX	MIN	TYP†	MAX	
V _{IK}		V _{CC} = 4.5 V, I _I = -18 mA	-1.2			-1.2			V
V _{OH}	B ports	V _{CC} = 4.5 V to 5.5 V, I _{OH} = -0.4 mA	V _{CC} -2			V _{CC} -2			V
		V _{CC} = 4.5 V	I _{OH} = -3 mA	2.4	3.2	2.4	3.2		
			I _{OH} = -12 mA	2					
						2			
V _{OL}		V _{CC} = 4.5 V	I _{OL} = 12 mA	0.25	0.4	0.25	0.4	V	
			I _{OL} = 24 mA				0.35		0.5
I _I	Control inputs	V _{CC} = 5.5 V, V _I = 7 V				0.1	0.1	mA	
	A or B ports	V _{CC} = 5.5 V, V _I = 5.5 V				0.1	0.1		
I _{IH}	Control inputs	V _{CC} = 5.5 V, V _I = 2.7 V				20	20	μA	
	A or B ports‡					20	20		
I _{IL}	Control inputs	V _{CC} = 5.5 V, V _I = 0.4 V				-0.2	-0.2	mA	
	A or B ports‡					-0.2	-0.2		
I _{OH}	A ports	V _{CC} = 4.5 V, V _{OH} = 5.5 V				0.1	0.1	mA	
I _{OS}	B ports	V _{CC} = 5.5 V, V _O = 2.25 V	-20	-112	-30	-112	mA		
I _{CC}	V _{CC} = 5.5 V		Outputs high	47	78	47	78	mA	
			Outputs low	55	88	55	88		
			Outputs disabled	55	88	55	88		

† All typical values are at V_{CC} = 5 V, T_A = 25°C.

‡ For I/O ports, the parameters I_{IH} and I_{IL} include the off-state output current.

§ The output conditions have been chosen to produce a current that closely approximates one half of the true short-circuit output current, I_{OS}.



**SN54ALS652, SN54ALS653, SN54AS651, SN54AS652
SN74ALS651A, SN74ALS652A, SN74ALS653, SN74ALS654, SN74AS651, SN74AS652
OCTAL BUS TRANSCEIVERS AND REGISTERS WITH 3-STATE OUTPUTS**

SDAS066E - DECEMBER 1983 - REVISED JANUARY 1995

electrical characteristics over recommended operating free-air temperature range (unless otherwise noted)

PARAMETER		TEST CONDITIONS		SN74ALS654			UNIT
				MIN	TYP†	MAX	
V _{IK}		V _{CC} = 4.5 V,	I _I = -18 mA			-1.2	V
V _{OH}	B ports	V _{CC} = 4.5 V to 5.5 V,		I _{OH} = -0.4 mA		V _{CC} -2	V
		V _{CC} = 4.5 V		I _{OH} = -3 mA		2.4 3.2	
				I _{OH} = -15 mA		2	
V _{OL}		V _{CC} = 4.5 V		I _{OL} = 12 mA		0.25 0.4	V
				I _{OL} = 24 mA		0.35 0.5	
I _I	Control inputs	V _{CC} = 5.5 V, V _I = 7 V				0.1	mA
	A or B ports	V _{CC} = 5.5 V, V _I = 5.5 V				0.1	
I _{IH}	Control inputs	V _{CC} = 5.5 V, V _I = 2.7 V				20	μA
	A or B ports‡					20	
I _{IL}	Control inputs	V _{CC} = 5.5 V, V _I = 0.4 V				-0.2	mA
	A or B ports‡					-0.2	
I _{OH}	A ports	V _{CC} = 4.5 V,	V _{OH} = 5.5 V			0.1	mA
I _O §	B ports	V _{CC} = 5.5 V,	V _O = 2.25 V	-30		-112	mA
I _{CC}		V _{CC} = 5.5 V		Outputs high		47 76	mA
				Outputs low		55 88	
				Outputs disabled		55 88	

† All typical values are at V_{CC} = 5 V, T_A = 25°C.

‡ For I/O ports, the parameters I_{IH} and I_{IL} include the off-state output current.

§ The output conditions have been chosen to produce a current that closely approximates one half of the true short-circuit output current, I_{OS}.



POST OFFICE BOX 655303 • DALLAS, TEXAS 75265

2-537

**SN54ALS652, SN54ALS653, SN54AS651, SN54AS652
SN74ALS651A, SN74ALS652A, SN74ALS653, SN74ALS654, SN74AS651, SN74AS652
OCTAL BUS TRANSCEIVERS AND REGISTERS WITH 3-STATE OUTPUTS**

SDAS066E - DECEMBER 1983 - REVISED JANUARY 1985

switching characteristics (see Figure 2)

PARAMETER	FROM (INPUT)	TO (OUTPUT)	V _{CC} = 4.5 V to 5.5 V, C _L = 50 pF, R _L = 680 Ω (A outputs), R _L = 500 Ω (B outputs), T _A = MIN to MAX†				UNIT
			SN54ALS653		SN74ALS653		
			MIN	MAX	MIN	MAX	
f _{max}			25		35		MHz
t _{PLH}	CLKBA	A	16	71	16	64	ns
t _{PHL}			6	24	6	22	
t _{PLH}	CLKAB	B	10	35	10	30	ns
t _{PHL}			5	20	5	17	
t _{PLH}	A	B	5	20	5	18	ns
t _{PHL}			1.5	18	2	15	
t _{PLH}	B	A	8	63	12	56	ns
t _{PHL}			2	18	2	15	
t _{PLH}	SBA‡ (with B high)	A	12	68	19	62	ns
t _{PHL}			5	27	5	25	
t _{PLH}	SBA‡ (with B low)	A	12	68	19	62	ns
t _{PHL}			5	27	5	25	
t _{PLH}	SAB‡ (with A high)	B	8	30	15	35	ns
t _{PHL}			6	25	6	22	
t _{PLH}	SAB‡ (with A low)	B	12	40	8	25	ns
t _{PHL}			6	25	6	22	
t _{PLH}	OEBA	A	6	35	6	30	ns
t _{PHL}			6	27	6	24	
t _{PZH}	OEAB	B	7	25	8	22	ns
t _{PZL}			6	25	6	22	
t _{PHZ}	OEAB	B	1	16	1	14	ns
t _{PLZ}			2	21	2	16	

† For conditions shown MIN or MAX, use the appropriate value specified under recommended operating conditions.

‡ These parameters are measured with the internal output state of the storage register opposite that of the bus input.



POST OFFICE BOX 655303 • DALLAS, TEXAS 75265

**SN54ALS652, SN54ALS653, SN54AS651, SN54AS652
SN74ALS651A, SN74ALS652A, SN74ALS653, SN74ALS654, SN74AS651, SN74AS652
OCTAL BUS TRANSCEIVERS AND REGISTERS WITH 3-STATE OUTPUTS**

SDAS066E - DECEMBER 1983 - REVISED JANUARY 1995

switching characteristics (see Figure 2)

PARAMETER	FROM (INPUT)	TO (OUTPUT)	V _{CC} = 4.5 V to 5.5 V, C _L = 50 pF, R _L = 680 Ω (A outputs), R _L = R ₂ = 500 Ω (B outputs), T _A = MIN to MAX†		UNIT
			SN74ALS654		
			MIN	MAX	
t _{max}			35		MHz
t _{PLH}	CLKBA	A	16	64	ns
t _{PHL}			6	22	
t _{PLH}	CLKAB	B	10	30	ns
t _{PHL}			5	17	
t _{PLH}	A	B	5	18	ns
t _{PHL}			2	15	
t _{PLH}	B	A	12	56	ns
t _{PHL}			2	15	
t _{PLH}	SBA‡ (with B high)	A	19	62	ns
t _{PHL}			5	25	
t _{PLH}	SBA‡ (with B low)	A	19	62	ns
t _{PHL}			5	25	
t _{PLH}	SAB‡ (with B high)	B	15	35	ns
t _{PHL}			6	22	
t _{PLH}	SAB‡ (with B low)	B	8	25	ns
t _{PHL}			6	22	
t _{PLH}	OEBA	A	6	30	ns
t _{PHL}			6	24	
t _{PZH}	OEAB	B	8	22	ns
t _{PZL}			6	22	
t _{PHZ}	OEAB	B	1	14	ns
t _{PLZ}			2	16	

† For conditions shown MIN or MAX, use the appropriate value specified under recommended operating conditions.

‡ These parameters are measured with the internal output state of the storage register opposite that of the bus input.



SN54ALS652, SN54ALS653, SN54AS651, SN54AS652
SN74ALS651A, SN74ALS652A, SN74ALS653, SN74ALS654, SN74AS651, SN74AS652
OCTAL BUS TRANSCEIVERS AND REGISTERS WITH 3-STATE OUTPUTS

SDAS068E - DECEMBER 1983 - REVISED JANUARY 1995

absolute maximum ratings over operating free-air temperature range (unless otherwise noted)†

Supply voltage, V_{CC}	7 V
Input voltage, V_I : Control inputs	7 V
I/O ports	5.5 V
Operating free-air temperature range, T_A : SN54AS651, SN54AS652	-55°C to 125°C
SN74AS651, SN74AS652	0°C to 70°C
Storage temperature range	-65°C to 150°C

† Stresses beyond those listed under "absolute maximum ratings" may cause permanent damage to the device. These are stress ratings only, and functional operation of the device at these or any other conditions beyond those indicated under "recommended operating conditions" is not implied. Exposure to absolute-maximum-rated conditions for extended periods may affect device reliability.

recommended operating conditions

		SN54AS651 SN54AS652			SN74AS651 SN74AS652			UNIT			
		MIN	NOM	MAX	MIN	NOM	MAX				
V_{CC}	Supply voltage	4.5	5	5.5	4.5	5	5.5	V			
V_{IH}	High-level input voltage	2			2			V			
V_{IL}	Low-level input voltage				0.8			V			
I_{OH}	High-level output current				-12			mA			
I_{OL}	Low-level output current				32			mA			
f_{clock}^*	Clock frequency	0			75			MHz			
t_w^*	Pulse duration	CLKBA or CLKAB high		6			5		ns		
		CLKBA or CLKAB low		7			6				
t_{su}^*	Setup time before CLKAB↑ or CLKBA↑	A or B		7			6		ns		
t_h^*	Hold time after CLKAB↑ or CLKBA	A or B		0			0		ns		
T_A	Operating free-air temperature	-55			125			0		70	°C

* On products compliant to MIL-STD-883, Class B, this parameter is based on characterized data but is not production tested.

**SN54ALS652, SN54ALS653, SN54AS651, SN54AS652
SN74ALS651A, SN74ALS652A, SN74ALS653, SN74ALS654, SN74AS651, SN74AS652
OCTAL BUS TRANSCEIVERS AND REGISTERS WITH 3-STATE OUTPUTS**

SDAS068E - DECEMBER 1983 - REVISED JANUARY 1995

electrical characteristics over recommended operating free-air temperature range (unless otherwise noted)

PARAMETER	TEST CONDITIONS	SN54AS651 SN54AS652		SN74AS651 SN74AS652		UNIT		
		MIN	TYP†	MAX	MIN		TYP†	MAX
V_{IK}	$V_{CC} = 4.5\text{ V}$, $I_I = -18\text{ mA}$			-1.2		V		
V_{OH}	$V_{CC} = 4.5\text{ V to }5.5\text{ V}$, $I_{OH} = -2\text{ mA}$	$V_{CC}-2$		$V_{CC}-2$		V		
	$V_{CC} = 4.5\text{ V}$	$I_{OH} = -3\text{ mA}$		2.4	3.2		2.4	3.2
		$I_{OH} = -12\text{ mA}$		2				
V_{OL}	$V_{CC} = 4.5\text{ V}$	$I_{OL} = 32\text{ mA}$		0.25	0.5	V		
		$I_{OL} = 48\text{ mA}$		0.35			0.5	
I_I	Control inputs	$V_{CC} = 5.5\text{ V}$, $V_I = 7\text{ V}$		0.1		mA		
	A or B ports	$V_{CC} = 5.5\text{ V}$, $V_I = 5.5\text{ V}$		0.1				
I_{IH}	Control inputs	$V_{CC} = 5.5\text{ V}$, $V_I = 2.7\text{ V}$		20		μA		
	A or B ports‡			70				
I_{IL}	Control input	$V_{CC} = 5.5\text{ V}$, $V_I = 0.4\text{ V}$		-0.5		mA		
	A or B ports‡			-0.75				
I_{OS}	$V_{CC} = 5.5\text{ V}$, $V_O = 2.25\text{ V}$	-30	-112	-30	-112	mA		
I_{CC}	'AS651	$V_{CC} = 5.5\text{ V}$	Outputs high		110	185	mA	
			Outputs low		120	195		
			Outputs disabled		130	195		
	'AS652	$V_{CC} = 5.5\text{ V}$	Outputs high		120	195		
			Outputs low		130	211		
			Outputs disabled		130	211		

† All typical values are at $V_{CC} = 5\text{ V}$, $T_A = 25\text{ }^\circ\text{C}$.

‡ For I/O ports, the parameters I_{IH} and I_{IL} include the off-state output current.

§ The output conditions have been chosen to produce a current that closely approximates one half of the true short-circuit output current, I_{OS} .



**SN54ALS652, SN54ALS653, SN54AS651, SN54AS652
 SN74ALS651A, SN74ALS652A, SN74ALS653, SN74ALS654, SN74AS651, SN74AS652
 OCTAL BUS TRANSCEIVERS AND REGISTERS WITH 3-STATE OUTPUTS**

SDAS068E - DECEMBER 1983 - REVISED JANUARY 1985

switching characteristics (see Figure 2)

PARAMETER	FROM (INPUT)	TO (OUTPUT)	V _{CC} = 4.5 V to 6.5 V, C _L = 50 pF, R ₁ = 500 Ω, R ₂ = 500 Ω, T _A = MIN to MAX†				UNIT
			SN54AS651		SN74AS651		
			MIN	MAX	MIN	MAX	
t _{max} *			75		90	MHz	
t _{PLH}	CLKBA or CLKAB	A or B	2	11	2	8.5	ns
t _{PHL}			2	10	2	9	
t _{PLH}	A or B	B or A	2	12	2	8	ns
t _{PHL}			1	8	1	7	
t _{PLH}	SBA or SAB‡	A or B	2	15	2	11	ns
t _{PHL}			2	11	2	9	
t _{PZH}	OEBA	A	2	11	2	10	ns
t _{PZL}			3	18	3	16	
t _{PHZ}	OEBA	A	2	10	2	9	ns
t _{PLZ}			2	10	2	9	
t _{PZH}	OEAB	B	3	12	3	11	ns
t _{PZL}			3	20	3	16	
t _{PHZ}	OEAB	B	2	11	2	10	ns
t _{PLZ}			2	12	2	11	

* On products compliant to MIL-STD-883, Class B, this parameter is based on characterized data but is not production tested.

† For conditions shown MIN or MAX, use the appropriate value specified under recommended operating conditions.

‡ These parameters are measured with the internal output state of the storage register opposite that of the bus input.



**SN54ALS652, SN54ALS653, SN54AS651, SN54AS652
SN74ALS651A, SN74ALS652A, SN74ALS653, SN74ALS654, SN74AS651, SN74AS652
OCTAL BUS TRANSCEIVERS AND REGISTERS WITH 3-STATE OUTPUTS**

SDAS068E - DECEMBER 1983 - REVISED JANUARY 1995

switching characteristics (see Figure 2)

PARAMETER	FROM (INPUT)	TO (OUTPUT)	V _{CC} = 4.5 V to 5.5 V, C _L = 50 pF, R ₁ = 500 Ω, R ₂ = 500 Ω, T _A = MIN to MAX†				UNIT
			SN54AS652		SN74AS652		
			MIN	MAX	TYP	MAX	
t _{max} *			75		90		MHz
t _{PLH}	CLKBA or CLKAB	A or B	2	11	2	8.5	ns
t _{PHL}			2	10	2	9	
t _{PLH}	A or B	B or A	2	12	2	9	ns
t _{PHL}			1	8	1	7	
t _{PLH}	SBA or SAB‡	A or B	2	15	2	11	ns
t _{PHL}			2	11	2	9	
t _{PZH}	OEBA	A	2	11	2	10	ns
t _{PZL}			3	18	3	16	
t _{PHZ}	OEBA	A	2	10	2	9	ns
t _{PLZ}			2	10	2	9	
t _{PZH}	OEAB	B	3	12	3	11	ns
t _{PZL}			3	20	3	16	
t _{PHZ}	OEAB	B	2	11	2	10	ns
t _{PLZ}			2	12	2	11	

* On products compliant to MIL-STD-883, Class B, this parameter is based on characterized data but is not production tested.

† For conditions shown MIN or MAX, use the appropriate value specified under recommended operating conditions.

‡ These parameters are measured with the internal output state of the storage register opposite that of the bus input.



**SN54ALS652, SN54ALS653, SN54AS651, SN54AS652
SN74ALS651A, SN74ALS652A, SN74ALS653, SN74ALS654, SN74AS651, SN74AS652
OCTAL BUS TRANSCEIVERS AND REGISTERS WITH 3-STATE OUTPUTS**

SDAS006E - DECEMBER 1983 - REVISED JANUARY 1985

PARAMETER MEASUREMENT INFORMATION

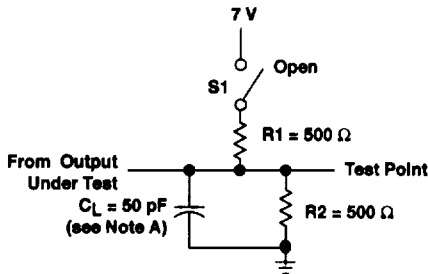

**LOAD CIRCUIT
FOR 3-STATE OUTPUTS**

SWITCH POSITION TABLE

TEST	S1
t_{PLH}	Open
t_{PHL}	Open
t_{PZH}	Open
t_{PZL}	Closed
t_{PHZ}	Open
t_{PLZ}	Closed

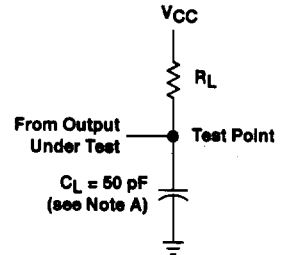

**LOAD CIRCUIT
FOR OPEN-COLLECTOR OUTPUTS**

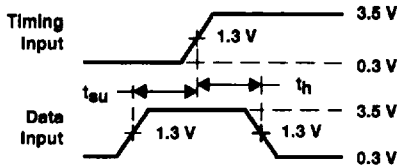

**VOLTAGE WAVEFORMS
SETUP AND HOLD TIMES**

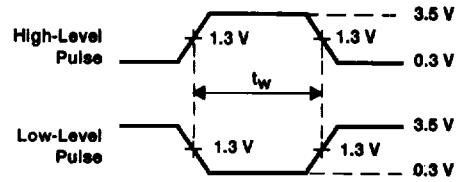

**VOLTAGE WAVEFORMS
PULSE DURATION**

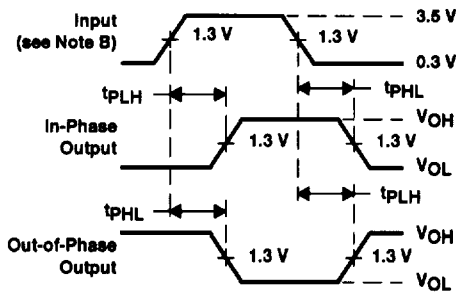

**VOLTAGE WAVEFORMS
PROPAGATION DELAY TIMES**

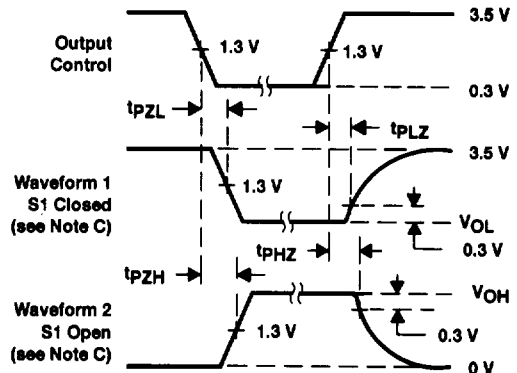

**VOLTAGE WAVEFORMS
ENABLE AND DISABLE TIMES, 3-STATE OUTPUTS**

- NOTES: A. C_L includes probe and jig capacitance.
 B. All input pulses are supplied by generators having the following characteristics: $PRR \leq 1$ MHz, $Z_O = 50 \Omega$, $t_r \leq 2$ ns, $t_f \leq 2$ ns.
 C. Waveform 1 is for an output with internal conditions such that the output is low except when disabled by the output control. Waveform 2 is for an output with internal conditions such that the output is high except when disabled by the output control.
 D. The outputs are measured one at a time with one transition per measurement.

Figure 2. Load Circuits and Voltage Waveforms



POST OFFICE BOX 665303 • DALLAS, TEXAS 75266