

# LR8563

## Low noise, fast response 300mA LDO regulator

### Features

- Low Power Consumption: 15uA ( Typ. )
- Low Output Noise (47uVRMS)
- Standby Mode: 0.1uA
- Low Dropout Voltage 0.16V@300mA (Typ.)
- High Ripple Rejection: 73dB@100Hz (Typ.)
- Low Temperature Coefficient:  $\pm 100\text{ppm}/^\circ\text{C}$
- Excellent Line Regulation: 0.05%/V
- Build-in Chip Enable And Discharge Circuit
- Output Voltage Range: 1.5V~4.5V (customized on command every 0.1V step)
- Highly Accurate:  $\pm 2\%$  ( $\pm 1\%$  customized)
- Output Current Limit

### Applications :

- Power source for cellular phones and various kind of PCSs
- Battery Powered equipment
- Power Management of MP3, PDA, DSC,

### General Description

LR8563 series is a group of positive voltage output, low power consumption, low dropout voltage regulator.

LR8563 can provide output value in the range of 1.5V~4.5V every 0.1V step. It also can be customized on command.

LR8563 includes high accuracy voltage reference, error amplifier, current limit circuit and output driver module with discharge capability.

LR8563 has excellent load and line transient response and good temperature characteristics, which can assure the stability of chip and power system. And it uses trimming technique to guarantee output voltage accuracy within  $\pm 2\%$ .

LR8563 is available in SOT-23-5, SC-70-5 packages which is lead free. It also can available in these packages with lead.

### LR8563 Typical Application Circuit

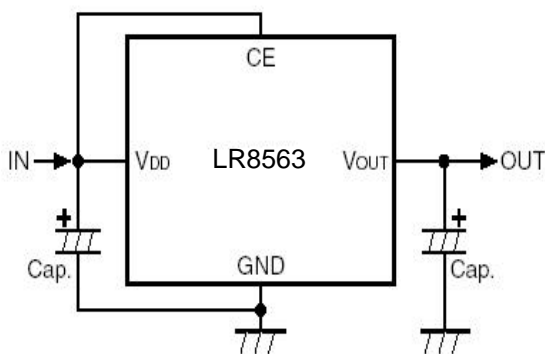

### LR8563 Typical Performance Characteristics

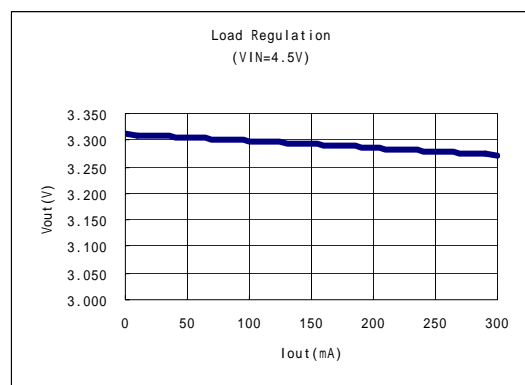

### Selection Guide

LR8563-XX X X

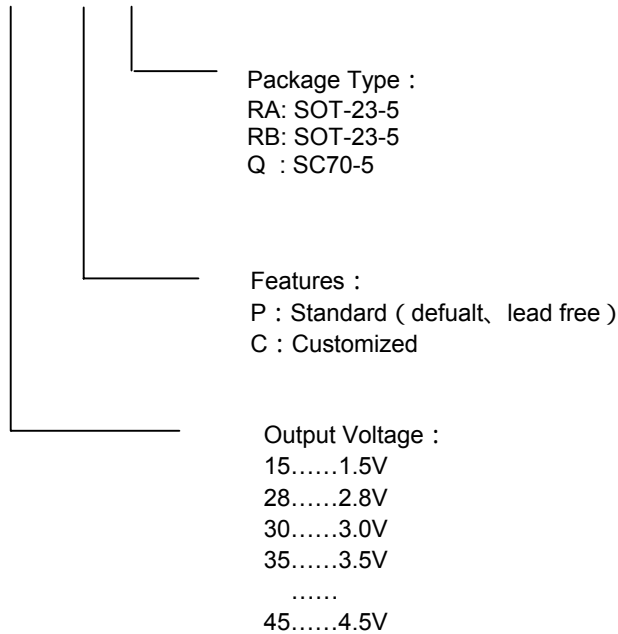

### Pin Assignment

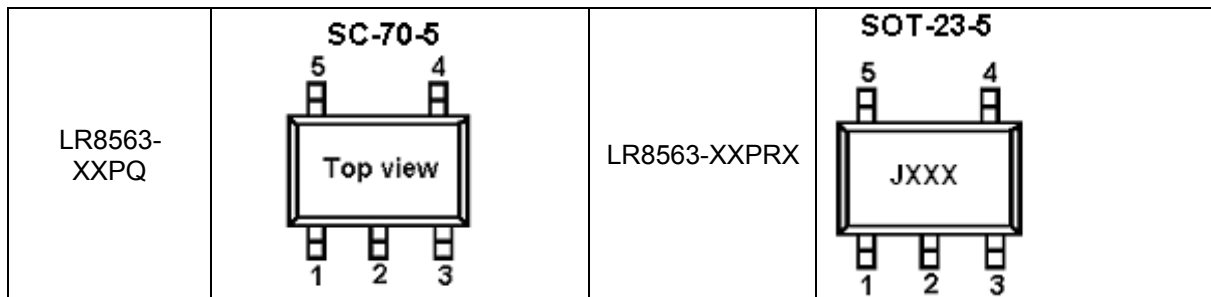

### Pin Description

Pin Number			Symbol	Function
SC-70-5	SOT-23-5A	SOT-23-5B		
5	5	1	VOUT	Output pin
1	1	3	VDD	Input Pin
2	2	2	GND	Ground Pin
3	3	4	CE	Chip Enable Pin
4	4	5	NC	No Connection

### Product Classification

Output Voltage	Package Type	Product Name	Package Type	Product Name	Package Type	Product Name
1.5V	SOT-23-5A	LR8563-15PRA	SOT-23-5B	LR8563-15PRB	SC70-5	LR8563-15PQ
1.8V	SOT-23-5A	LR8563-18PRA	SOT-23-5B	LR8563-18PRB	SC70-5	LR8563-18PQ
2.1V	SOT-23-5A	LR8563-21PRA	SOT-23-5B	LR8563-21PRB	SC70-5	LR8563-21PQ
2.5V	SOT-23-5A	LR8563-25PRA	SOT-23-5B	LR8563-25PRB	SC70-5	LR8563-25PQ
2.8V	SOT-23-5A	LR8563-28PRA	SOT-23-5B	LR8563-28PRB	SC70-5	LR8563-28PQ
3.0V	SOT-23-5A	LR8563-30PRA	SOT-23-5B	LR8563-30PRB	SC70-5	LR8563-30PQ
3.2V	SOT-23-5A	LR8563-32PRA	SOT-23-5B	LR8563-32PRB	SC70-5	LR8563-32PQ
3.3V	SOT-23-5A	LR8563-33PRA	SOT-23-5B	LR8563-33PRB	SC70-5	LR8563-33PQ
3.5V	SOT-23-5A	LR8563-35PRA	SOT-23-5B	LR8563-35PRB	SC70-5	LR8563-35PQ
⋮	⋮	⋮	⋮	⋮	⋮	⋮
4.5V	SOT-23-5A	LR8563-45PRA	SOT-23-5B	LR8563-45PRB	SC70-5	LR8563-45PQ

### Product Marking information

**SC70-5**

**SOT23-5A**

**SOT23-5B**

① : Output current & EN availability  
 ② : Output voltage  
 ③ : Year of manufacturing  
 ④ : Week of manufacturing

① LR8563 with output current 300mA

②

③ The year of manufacturing. "5" stands for year 2005, "6" stands for year 2006, and "0" for year 2010.

Code	Vout	Code	Vout	Code	Vout
5	1.5V	6	2.6V	7	3.7V
6	1.6V	7	2.7V	8	3.8V
7	1.7V	8	2.8V	9	3.9V
8	1.8V	9	2.9V	0	4.0V
9	1.9V	0	3.0V	1	4.1V
0	2.0V	1	3.1V	2	4.2V
1	2.1V	2	3.2V	3	4.3V
2	2.2V	3	3.3V	4	4.4V
3	2.3V	4	3.4V	5	4.5V
4	2.4V	5	3.5V		
5	2.5V	6	3.6V		

④

Code	Week of Mfg	Code	Week of Mfg	Code	Week of Mfg	Code	Week of Mfg	Code	Week of Mfg
A	1	L	12	W	23	H	34	S	45
B	2	M	13	X	24	T	35	F	46
C	3	N	14	Y	25	J	36	U	47
D	4	O	15	Z	26	K	37	V	48
E	5	P	16	A	27	L	38	W	49
F	6	Q	17	B	28	M	39	X	50
G	7	R	18	C	29	N	40	Y	51
H	8	S	19	D	30	O	41	Z	52
I	9	T	20	E	31	P	42		
J	10	U	21	F	32	Q	43		
K	11	V	22	G	33	R	44		

**Block Diagram**

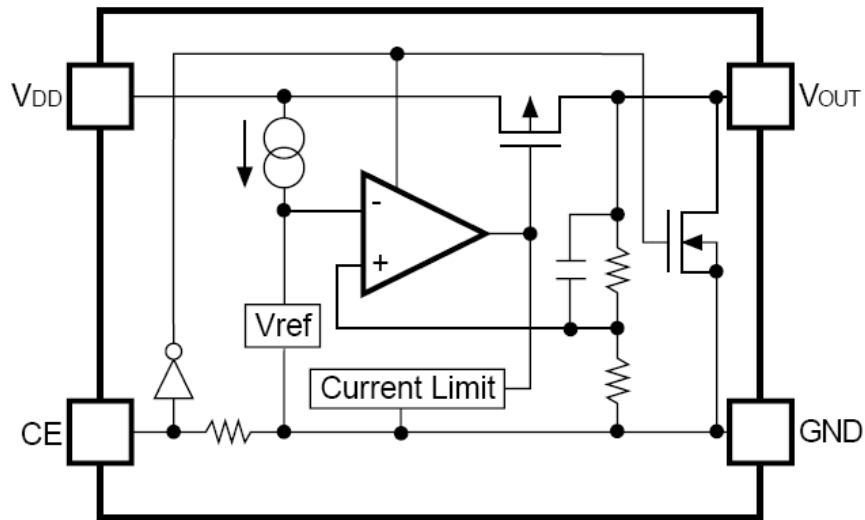

**Absolute Maximum Ratings :**

Max input voltage	-----8V
Junction Temperature (T <sub>J</sub> )	-----125°C
Output Current	-----300mA
Power Dissipation	
SOT-23-5	-----250mW
Storage Temperature (T <sub>s</sub> )	-----45°C ~ 150°C

**Recommended Work Conditions :**

Item	Min	Recommended	Max	unit
Input Voltage Range			6	V
Ambient Temperature	-40		85	°C

### Electrical Characteristics

( Test Conditions:  $C_{in}=1\mu F, C_{out}=3.4\mu F, T_A=25^\circ C$ , unless otherwise specified. )

#### LR8563 for arbitrary output voltage

Symbol	Parameter	Conditions	Min	Typ	Max	Units
$V_{in}$	Input Voltage				6	V
$V_{out}$	Output Voltage	$V_{in}=\text{Set } V_{out}+1V$ $1mA \leq I_{out} \leq 30mA$	$V_{out} \times 0.98$	$V_{out1}$	$V_{out} \times 1.02$	V
$I_{out}$ (Max.)	Maximun Output Current	$V_{in}-V_{out}=1V$	300			mA
$V_{drop}^1$	Dropout Voltage, $V_{out} \geq 2.8V$	$I_{out}=100mA$		50	80	mV
		$I_{out}=300mA$		160	220	mV
$\frac{\Delta V_{out}}{\Delta V_{in} \cdot V_{out}}$	Line Regulation	$I_{out}=40mA$ $2.8V \leq V_{in} \leq 6V$		0.05	0.2	%/V
$\frac{\Delta V_{out}}{\Delta I_{out}}$	Load Regulation	$V_{in}=\text{Set } V_{out}+1V$ $1mA \leq I_{out} \leq 300mA$		30	50	mV
$I_{ss}$	Supply Current	$V_{in}=\text{Set } V_{out}+1V$		15	25	$\mu A$
$I_{standby}$	Supply Current (Standby)	$V_{in}=\text{Set } V_{out}+1V$ $V_{ce}=\text{GND}$		0.1	1.0	$\mu A$
$\frac{\Delta V_{out}}{\Delta T \cdot V_{out}}$	Output Voltage Temperature Coefficiency	$I_{out}=30mA$		$\pm 100$		ppm/ $^\circ C$
PSRR	Ripple Rejection	$F=100Hz,$ Ripple=0.5Vp-p $V_{in}=\text{Set } V_{out}+1V$		70		dB
$I_{lim}$	Short Current Limit	$V_{out}=0V$		500		mA
$R_{pd}$	CE Pull down Resistance		2.0	5.0	10.0	$M\Omega$
$V_{ceh}$	CE Input Voltage "H"		1.5		$V_{in}$	V
$V_{cel}$	CE Input Voltage "L"		0		0.25	V
$E_n$	Output Noise	$BW=10Hz \sim 100kHz$		47		$\mu V_{rms}$

1)  $V_{drop} = V_{in1} - (V_{out2} \times 0.98)$   $V_{out2}$  is the output voltage when  $V_{in} = V_{out1} + 1.0V$  and  $I_{out} = 300mA$   
 $V_{in1}$  is the input voltage at which the output voltage becomes 98% of  $V_{out1}$  after gradually decreasing the input voltage.

### Typical Application Circuit

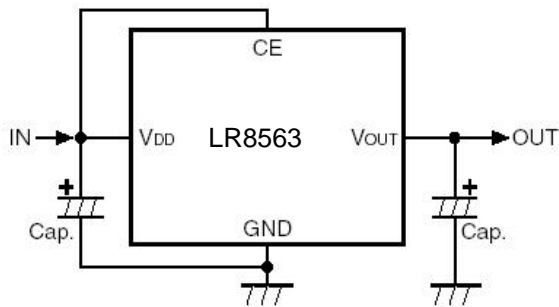

### Application hints

NOTE1: Input capacitor ( $C_{in}=1\mu F$ ) is recommended in all application circuit.

NOTE2: Output capacitor ( $C_{out}=3.3\mu F/4.7\mu F$ ) is recommended in all application to assure the stability of circuit.

### Explanation

LR8563 series is a group of positive voltage output, low noise, low power consumption, low dropout voltage regulator.

LR8563 can provide output value in the range of 1.5V~4.5V every 0.1V step. It also can be customized on command.

LR8563 includes high accuracy voltage reference, error amplifier, current limit circuit and output driver module.

LR8563 has excellent load and line transient response and good temperature characteristics, which can assure the stability of chip and power system. And it uses trimming technique to guarantee output voltage accuracy within  $\pm 2\%$ .

### Typical Performance Characteristics

1) Output Voltage vs. Output Current (with output short protection)

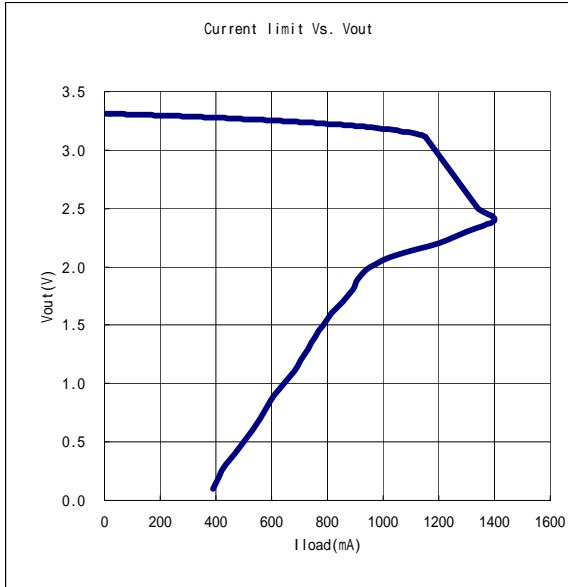

2) Output Voltage vs. Input Voltage

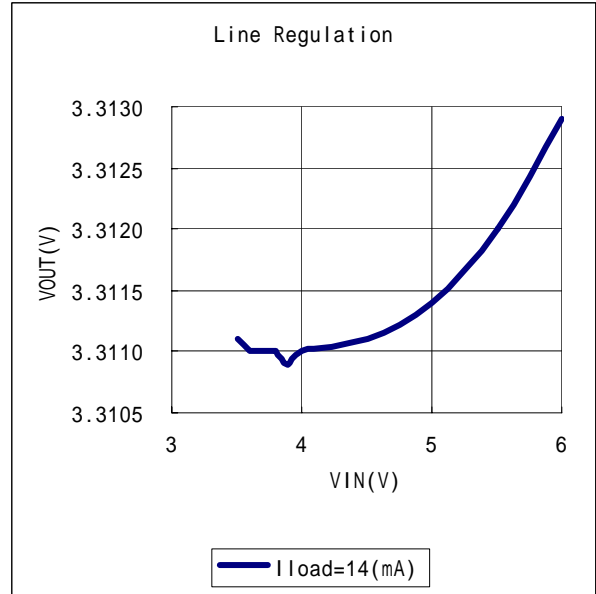

3) Dropout Voltage vs. Output Current

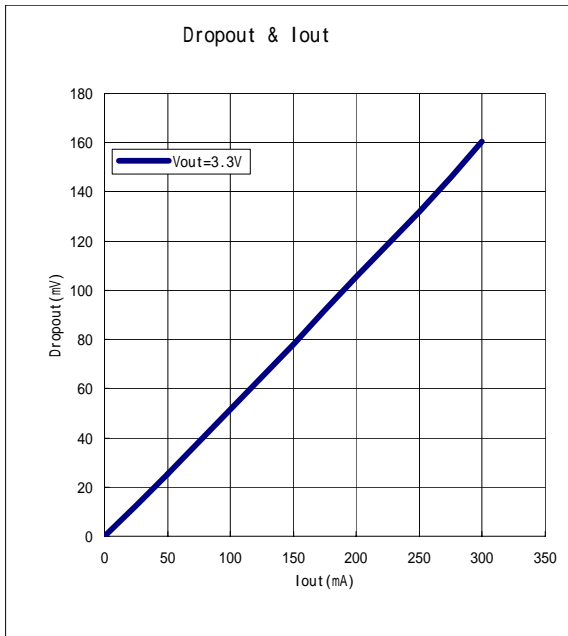

4) Ripple rejection vs. Frequency

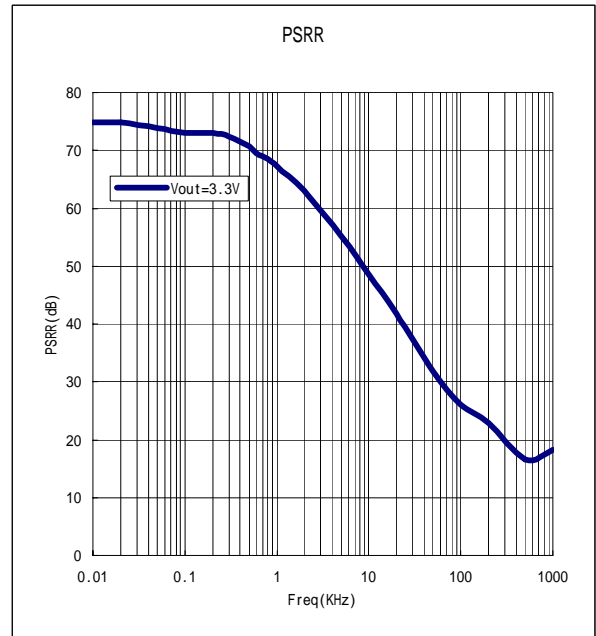

5) Line transient response  
 $C_{in}=C_{out}=1\mu F$   $I_{out}=25mA$   $V_{out}=3.3V$

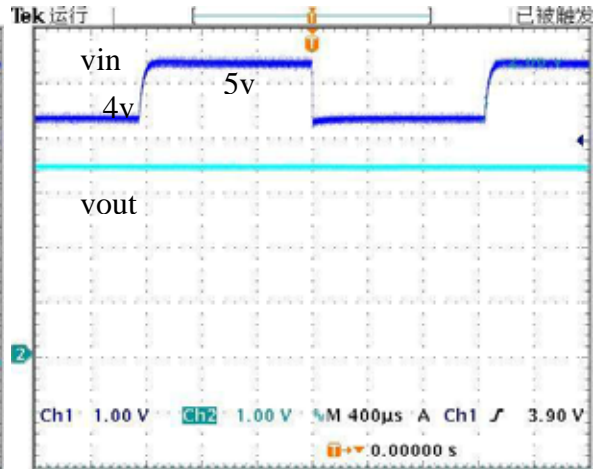
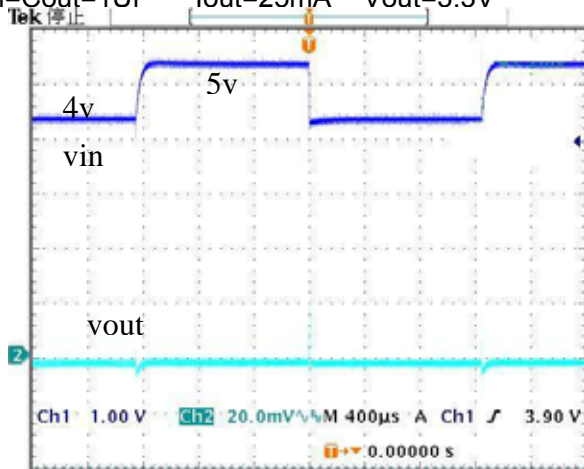

6) Load transient response  
 $C_{in}=C_{out}=1\mu F$   $V_{in}=4.5V$   $V_{out}=3.3V$

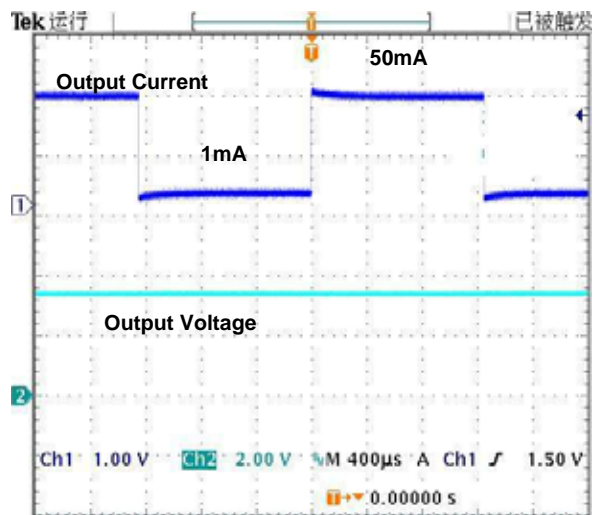
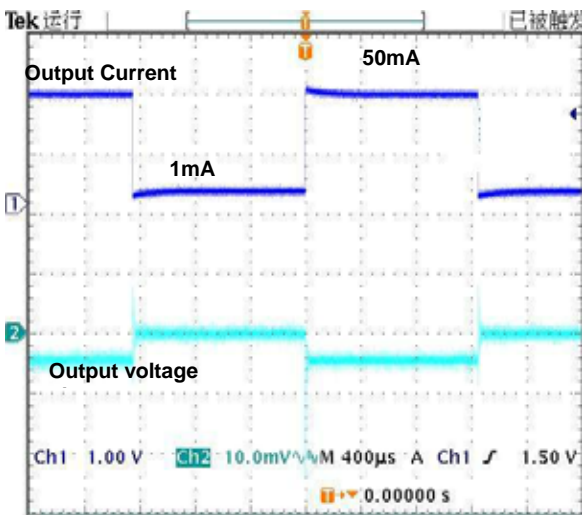

7) Startup response

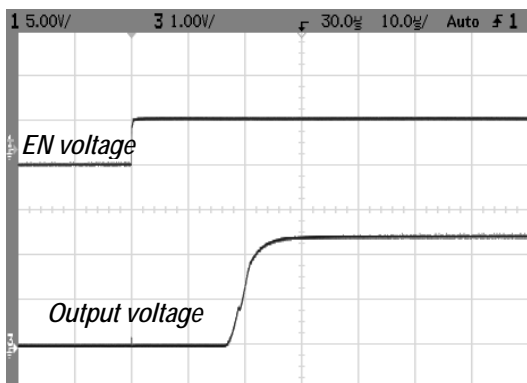

8) Shutdown response

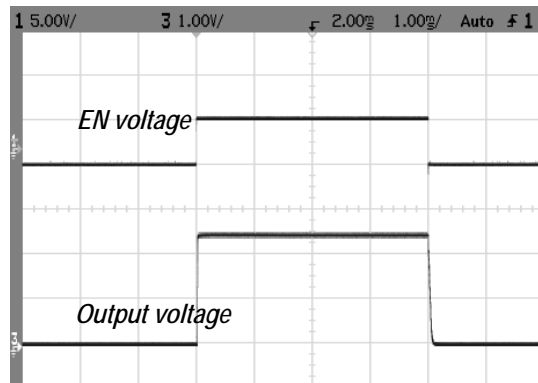



Package Information

SOT-23-5

Package specification

Unit: mm

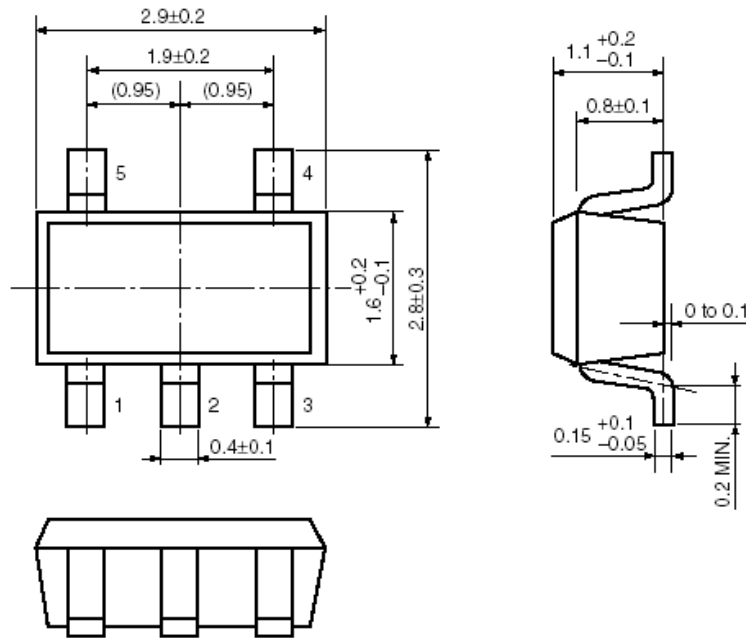

SC70-5

Package specification

Unit: mm

