

# Terminal Voltage $\pm 5V$ , 32 Taps

## X9511

### PushPot™ Potentiometer (Push Button Controlled)

#### FEATURES

- **Push Button Controlled**
- **Low Power CMOS**
  - Active Current, 3mA Max
  - Standby Current, 200 $\mu$ A Max
- **31 Resistive Elements**
  - Temperature Compensated
  - $\pm 20\%$  End to End Resistance Range
  - $-5V$  to  $+5V$  Range
- **32 Wiper Tap Points**
  - Wiper Positioned via Two Push Button Inputs
  - Slow & Fast Scan Modes
  - AUTOSTORE® Option
  - Manual Store Option
  - Wiper Position Stored in Nonvolatile Memory and Recalled on Power-Up
- **100 Year Wiper Position Data Retention**
- X9511Z = 1K $\Omega$
- X9511W = 10K $\Omega$
- **Packages**
  - 8-Lead PDIP
  - 8-Lead SOIC

#### DESCRIPTION

The Xicor X9511 is a push button controlled, potentiometer and is ideal for push button controlled resistance trimming.

The X9511 is a resistor array composed of 31 resistive elements. Between each element and at either end are tap points accessible to the wiper element. The position of the wiper element is controlled by the  $\overline{PU}$  and  $\overline{PD}$  inputs. The position of the wiper can be automatically stored in E<sup>2</sup> memory and then be recalled upon a subsequent power-on operation.

The resolution of the X9511 is equal to the maximum resistance value divided by 31. As an example, for the X9511W (10K $\Omega$ ) each tap point represents 323 $\Omega$ .

All Xicor nonvolatile products are designed and tested for applications requiring extended endurance and data retention.

#### FUNCTIONAL DIAGRAM

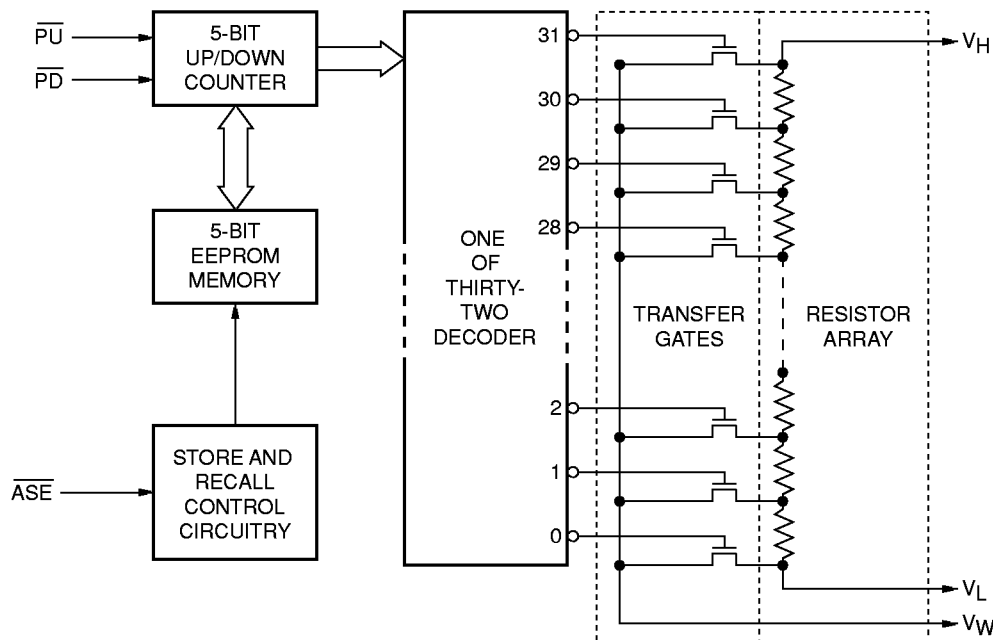

# X9511

## PIN DESCRIPTIONS

### $V_H$ and $V_L$

The high ( $V_H$ ) and low ( $V_L$ ) terminals of the X9511 are equivalent to the fixed terminals of a mechanical potentiometer. The minimum voltage is  $-5V$  and the maximum is  $+5V$ . It should be noted that the terminology of  $V_L$  and  $V_H$  references the relative position of the terminal in relation to wiper movement direction selected by the  $\overline{PU}$  and  $\overline{PD}$  inputs and not the voltage potential on the terminal.

### $\overline{PU}$

The debounced  $\overline{PU}$  input is for incrementing the wiper position. An on-chip pull-up holds the  $\overline{PU}$  input HIGH. A switch closure to ground or a LOW logic level will, after a debounce time, move the wiper to the next adjacent higher tap position.

### $\overline{PD}$

The debounced  $\overline{PD}$  input is for decrementing the wiper position. An on-chip pull-up holds the  $\overline{PD}$  input HIGH. A switch closure to ground or a LOW logic level will, after a debounce time, move the wiper to the next adjacent lower tap position.

### $\overline{ASE}$

The debounced  $\overline{ASE}$  (AUTOSTORE enable) pin can be in one of two states:

$V_{IL}$  – Autostore is enabled. When  $V_{CC}$  powers-down an automatic store cycle takes place.

$V_{IH}$  – AUTOSTORE is disabled. A LOW to HIGH will initiate a manual store operation. This is for a user who wishes to connect a push button switch to this pin. For every valid push, the X9511 will store the current wiper position to the E<sup>2</sup>PROM.

## PIN CONFIGURATION

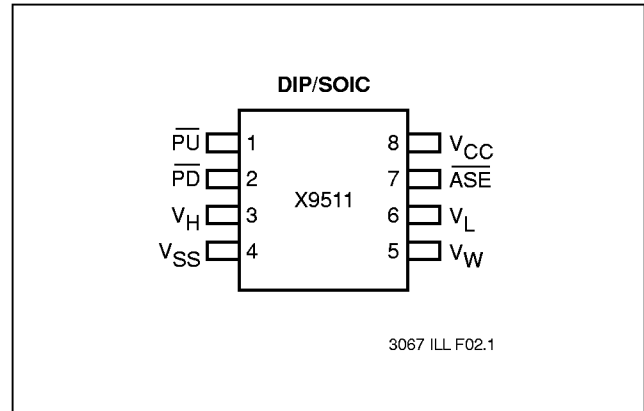

## PIN NAMES

Symbol	Description
$V_H$	High Terminal
$V_W$	Wiper Terminal
$V_L$	Low Terminal
$V_{SS}$	Ground
$V_{CC}$	Supply Voltage
$\overline{PU}$	Push Up Input
$\overline{PD}$	Push Down Input
$\overline{ASE}$	AUTOSTORE Enable Input

3067 FRM T01.1

# X9511

## DEVICE OPERATION

There are three sections of the X9511: the input control, counter and decode section; the E<sup>2</sup>PROM memory; and the resistor array. The input control section operates just like an up/down counter. The output of this counter is decoded to turn on a single electronic switch connecting a point on the resistor array to the wiper output. Under the proper conditions the contents of the counter can be stored in E<sup>2</sup>PROM memory and retained for future use. The resistor array is comprised of 31 individual resistors connected in series. At either end of the array and between each resistor is an electronic switch that transfers the potential at that point to the wiper.

The X9511 is designed to interface directly to two push button switches for effectively moving the wiper up or down. The  $\overline{PU}$  and  $\overline{PD}$  inputs increment or decrement a 5-bit counter respectively. The output of this counter is decoded to select one of the thirty-two wiper positions along the resistive array. The wiper increment input,  $\overline{PU}$  and the wiper decrement input,  $\overline{PD}$  are both connected to an internal pull-up so that they normally remain HIGH. When pulled LOW by an external push button switch or a logic LOW level input, the wiper will be switched to the next adjacent tap position.

Internal debounce circuitry prevents inadvertent switching of the wiper position if  $\overline{PU}$  or  $\overline{PD}$  remain LOW for less than 40ms, typical. Each of the buttons can be pushed either once for a single increment/decrement or continuously for a multiple increments/decrements. The number of increments/decrements of the wiper position depend

on how long the button is being pushed. When making a continuous push, after the first second, the increment/decrement speed increases. For the first second the device will be in the slow scan mode. Then if the button is held for longer than 1 second the device will go into the fast scan mode. As soon as the button is released the X9511 will return to a standby condition.

The wiper, when at either fixed terminal, acts like its mechanical equivalent and does not move beyond the last position. That is, the counter does not wrap around when clocked to either extreme.

## AUTOSTORE

The value of the counter is stored in E<sup>2</sup>PROM memory whenever the chip senses a power-down of  $V_{CC}$  while  $\overline{ASE}$  is enabled (held LOW). When power is restored, the content of the memory is recalled and the counter reset to the last value stored.

If AUTOSTORE is to be implemented,  $\overline{ASE}$  is typically hard wired to  $V_{SS}$ . If  $\overline{ASE}$  is held HIGH during power-up and then taken LOW, the wiper will not respond to the  $\overline{PU}$  or  $\overline{PD}$  inputs until  $\overline{ASE}$  is brought HIGH and held HIGH.

## Manual (Push Button) Store

When  $\overline{ASE}$  is not enabled (held HIGH) a push button switch may be used to pull  $\overline{ASE}$  LOW and released to perform a manual store of the wiper position.

## R<sub>TOTAL</sub> with V<sub>CC</sub> Removed

The end to end resistance of the array will fluctuate once  $V_{CC}$  is removed.

### Typical circuit with $\overline{ASE}$ store pin controlled by push button switch

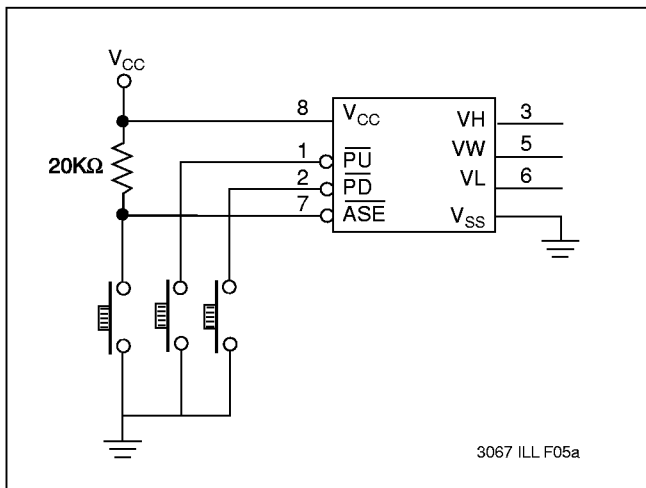

### Typical circuit with $\overline{ASE}$ store pin used in AUTOSTORE mode

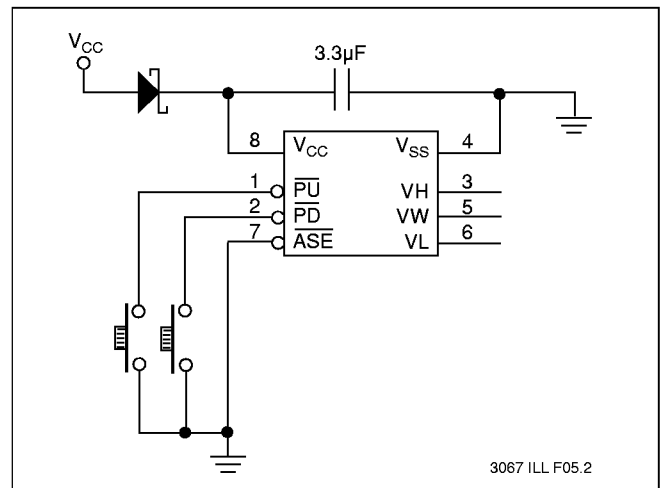

# X9511

## ABSOLUTE MAXIMUM RATINGS\*

Temperature under Bias .....	-65°C to +135°C
Storage Temperature .....	-65°C to +150°C
Voltage on $\overline{P\overline{U}}$ , $\overline{P\overline{D}}$ , and $V_{CC}$ with Respect to $V_{SS}$ .....	-1V to +7V
Voltage on $V_H$ and $V_L$ Referenced to $V_{SS}$ .....	-8V to +8V
$\Delta V =  V_H - V_L $ X9511Z .....	4V
X9511W .....	10V
Lead Temperature (Soldering 10 seconds) .....	300°C
Wiper Current .....	±1mA

## ANALOG CHARACTERISTICS

### Electrical Characteristics

End-to-End Resistance Tolerance .....	±20%
Power Rating at 25°C	
X9511Z .....	16mW
X9511W .....	10mW
Wiper Current .....	±1mA Max.
Typical Wiper Resistance .....	40Ω at 1mA
Typical Noise .....	< -120dB/√Hz Ref: 1V

### Resolution

Resistance .....	3%
------------------	----

### Linearity

Absolute Linearity <sup>(1)</sup> .....	±1.0 MI <sup>(2)</sup>
Relative Linearity <sup>(3)</sup> .....	±0.2 MI <sup>(2)</sup>

**Notes:** (1) Absolute Linearity is utilized to determine actual wiper voltage versus expected voltage

$$= (V_{w(n)}(\text{actual}) - V_{w(n)}(\text{expected})) = \pm 1 \text{ MI Maximum.}$$

(2) 1 MI = Minimum Increment =  $R_{TOT}/31$ .

(3) Relative Linearity is a measure of the error in step size between taps =  $V_{w(n+1)} - [V_{w(n)} + \text{MI}] = +0.2 \text{ MI}$ .

## \*COMMENT

Stresses above those listed under “Absolute Maximum Ratings” may cause permanent damage to the device. This is a stress rating only and the functional operation of the device at these or any other conditions above those listed in the operational sections of this specification is not implied. Exposure to absolute maximum rating conditions for extended periods may affect device reliability.

### Temperature Coefficient

-40°C to +85°C

X9511Z .....	+600 ppm/°C Typical
X9511W .....	+300 ppm/°C Typical
Ratiometric Temperature Coefficient .....	±20 ppm

### Wiper Adjustability

Unlimited Wiper Adjustment (Non-Store operation)	
Wiper Position Store Operations .....	100,000 Data Changes

### Physical Characteristics

Marking Includes

Manufacturer's Trademark
Resistance Value or Code
Date Code

## SYMBOL TABLE

WAVEFORM	INPUTS	OUTPUTS
	Must be steady	Will be steady
	May change from LOW to HIGH	Will change from LOW to HIGH
	May change from HIGH to LOW	Will change from HIGH to LOW
	Don't Care: Changes Allowed	Changing: State Not Known
	N/A	Center Line is High Impedance

# X9511

## RECOMMENDED OPERATING CONDITIONS

Temperature	Min.	Max.
Commercial	0°C	+70°C
Industrial	-40°C	+85°C
Military	-55°C	+125°C

3067 FRM T03

Supply Voltage	Limits
X9511	5V ±10%

3067 FRM T04.1

## D.C. OPERATING CHARACTERISTICS (Over recommended operating conditions unless otherwise specified.)

Symbol	Parameter	Limits			Units	Test Conditions
		Min.	Typ. <sup>(4)</sup>	Max.		
$I_{CC}$	$V_{CC}$ Active Current		1	3	mA	$\overline{PU}$ or $\overline{PD}$ held at $V_{IL}$ the other at $V_{IH}$
$I_{SB}$	Standby Supply Current		100	200	μA	$\overline{PU} = \overline{PD} = V_{IH}$
$I_{LI}$	$\overline{PU}$ , $\overline{PD}$ , $\overline{ASE}$ Input Leakage Current			10	μA	$V_{IN} = V_{SS}$ to $V_{CC}$
$V_{IH}$	$\overline{PU}$ , $\overline{PD}$ , $\overline{ASE}$ Input HIGH Voltage	2		$V_{CC} + 1$	V	
$V_{IL}$	$\overline{PU}$ , $\overline{PD}$ , $\overline{ASE}$ Input LOW Voltage	-1		0.8	V	
$R_W$	Wiper Resistance		40	100	Ω	Max. Wiper Current ±1mA
$V_{VH}$	VH Terminal Voltage	-5		+5	V	
$V_{VL}$	VL Terminal Voltage	-5		+5	V	
$C_{IN}^{(5)}$	$\overline{ASE}$ , $\overline{PU}$ , $\overline{PD}$ Input Capacitance			10	pF	$V_{CC} = 5V$ , $V_{IN} = 0V$ , $T_A = 25^\circ C$ , $f = 1MHz$

3067 FRM T05.4

## STANDARD PARTS

Part Number	Maximum Resistance	Wiper Increments	Minimum Resistance
X9511Z	1KW	32.3Ω	40Ω
X9511W	10KW	323Ω	40Ω

3067 FRM T08.1

- Notes:** (4) Typical values are for  $T_A = 25^\circ C$  and nominal supply voltage.  
 (5) This parameter is periodically sampled and not 100% tested.

# X9511

## A.C. OPERATING CHARACTERISTICS (Over recommended operating conditions unless otherwise specified.)

Symbol	Parameter	Limits			Units
		Min.	Typ. <sup>(6)</sup>	Max.	
$t_{GAP}$	Time Between Two Separate Push Button Events	0			$\mu s$
$t_{DB}$	Debounce Time		30	60	ms
$t_{S\ SLOW}$	After Debounce to Wiper Change on a Slow Mode	100	250	375	ms
$t_{S\ FAST}^{(7)}$	Wiper Change on a Fast Mode	25	50	75	ms
$t_{PU}^{(7)}$	Power Up to Wiper Stable			500	$\mu s$
$t_{R\ V_{CC}}^{(7)}$	$V_{CC}$ Power-up Rate	0.2		50	mV/ $\mu s$
$t_{ASTO}^{(7)}$	AUTOSTORE Cycle Time	2			ms
$V_{ASTH}^{(7)}$	AUTOSTORE Threshold Voltage		4		V
$V_{ASEND}^{(7)}$	AUTOSTORE Cycle End Voltage		3.5		V

3067 FRM T07.3

### AUTOSTORE Cycle Timing Diagram

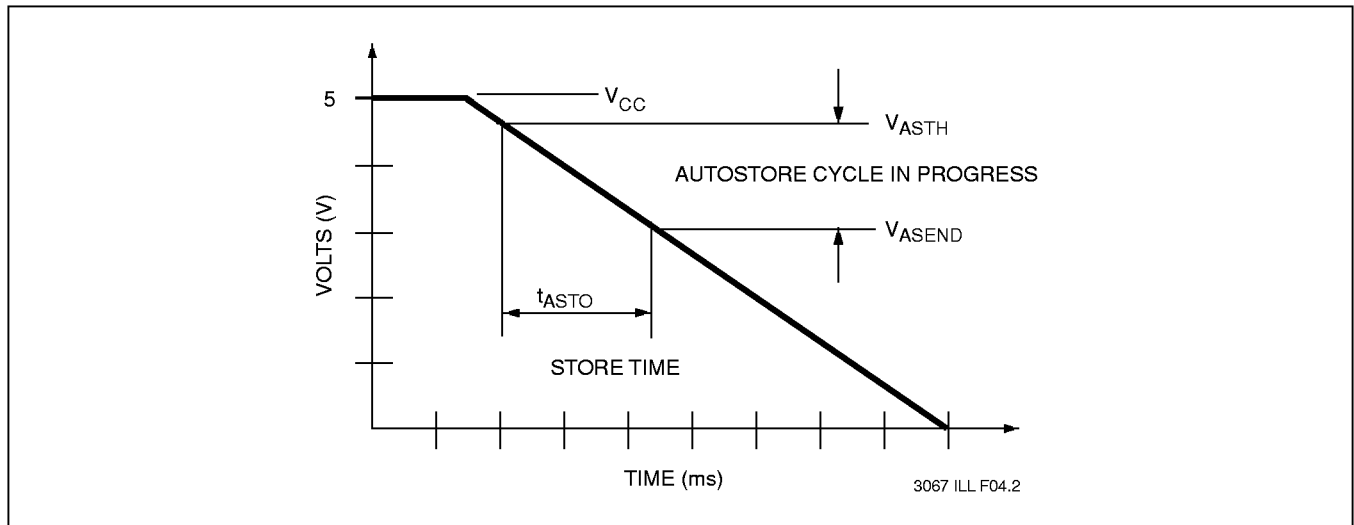

- Notes:**  $V_{ASTH}$  – AUTOSTORE threshold voltage  
 $V_{ASEND}$  – AUTOSTORE cycle end voltage  
 $t_{ASTO}$  – AUTOSTORE cycle time  
 (6) Typical values are for  $T_A = 25^\circ C$  and nominal supply voltage.  
 (7) This parameter is periodically sampled and not 100% tested.

# X9511

## Slow Mode Timing

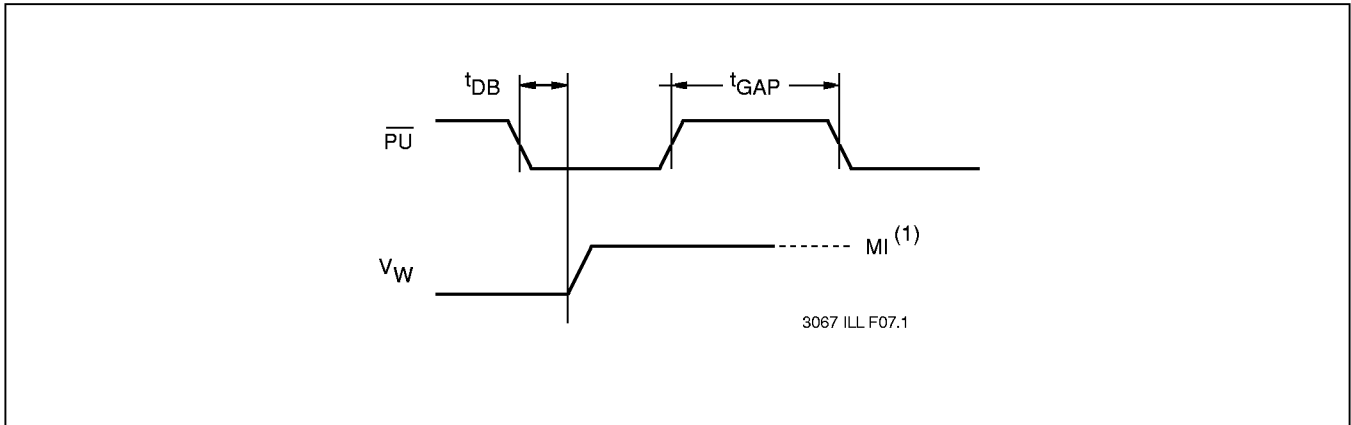

**Notes:** (1) MI in the A.C. timing diagram refers to the minimum incremental change in the wiper voltage.

## Fast Mode Timing

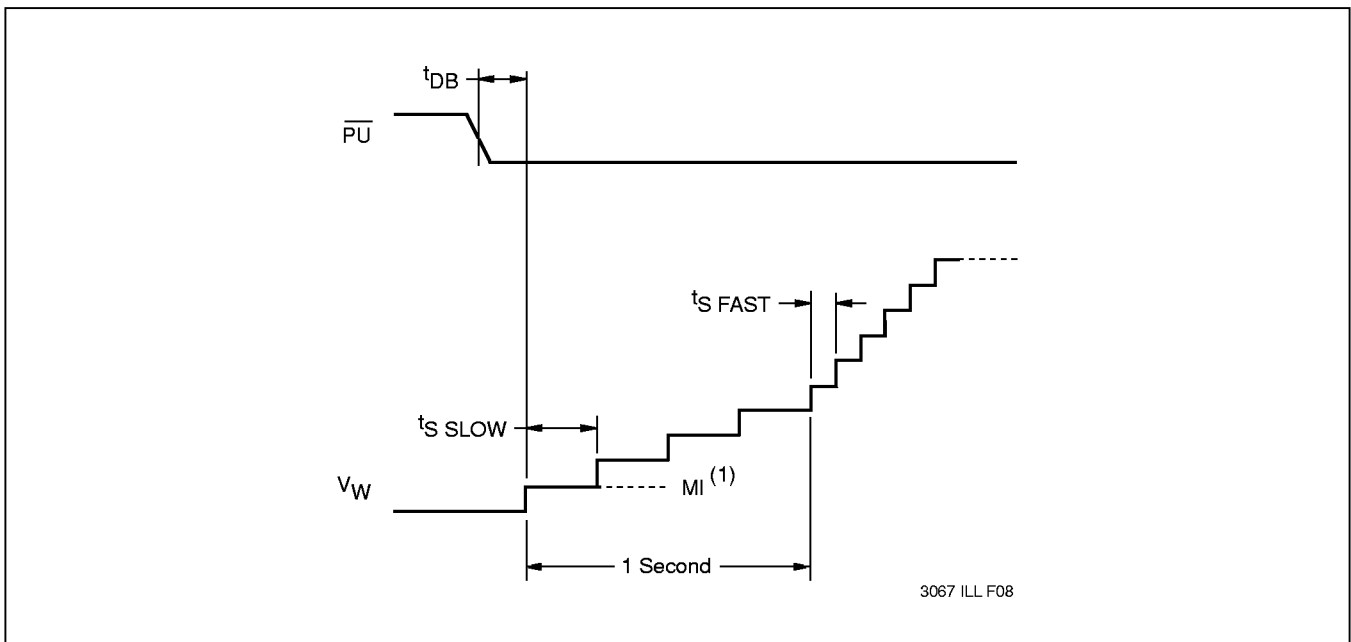

**Notes:** (1) MI in the A.C. timing diagram refers to the minimum incremental change in the wiper voltage.

## PACKAGING INFORMATION

### 8-LEAD PLASTIC DUAL IN-LINE PACKAGE TYPE P

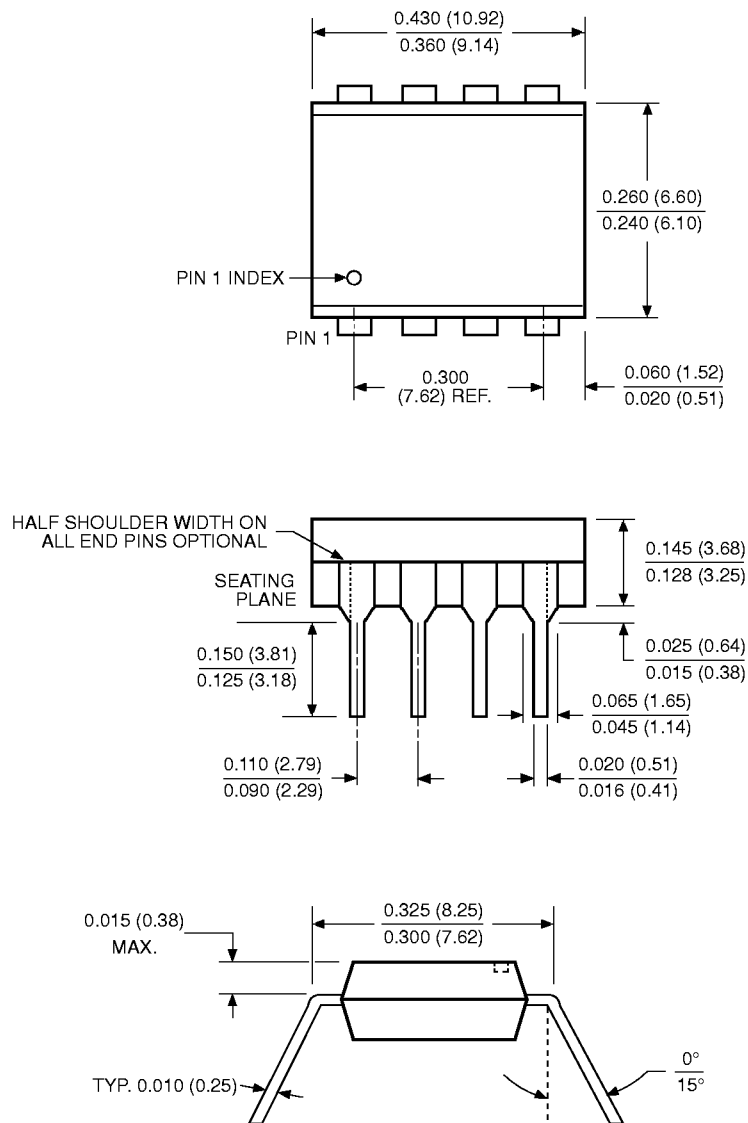

**NOTE:**

1. ALL DIMENSIONS IN INCHES (IN PARENTHESES IN MILLIMETERS)
2. PACKAGE DIMENSIONS EXCLUDE MOLDING FLASH



# X9511

## PACKAGING INFORMATION

### 8-LEAD PLASTIC SMALL OUTLINE GULL WING PACKAGE TYPE S

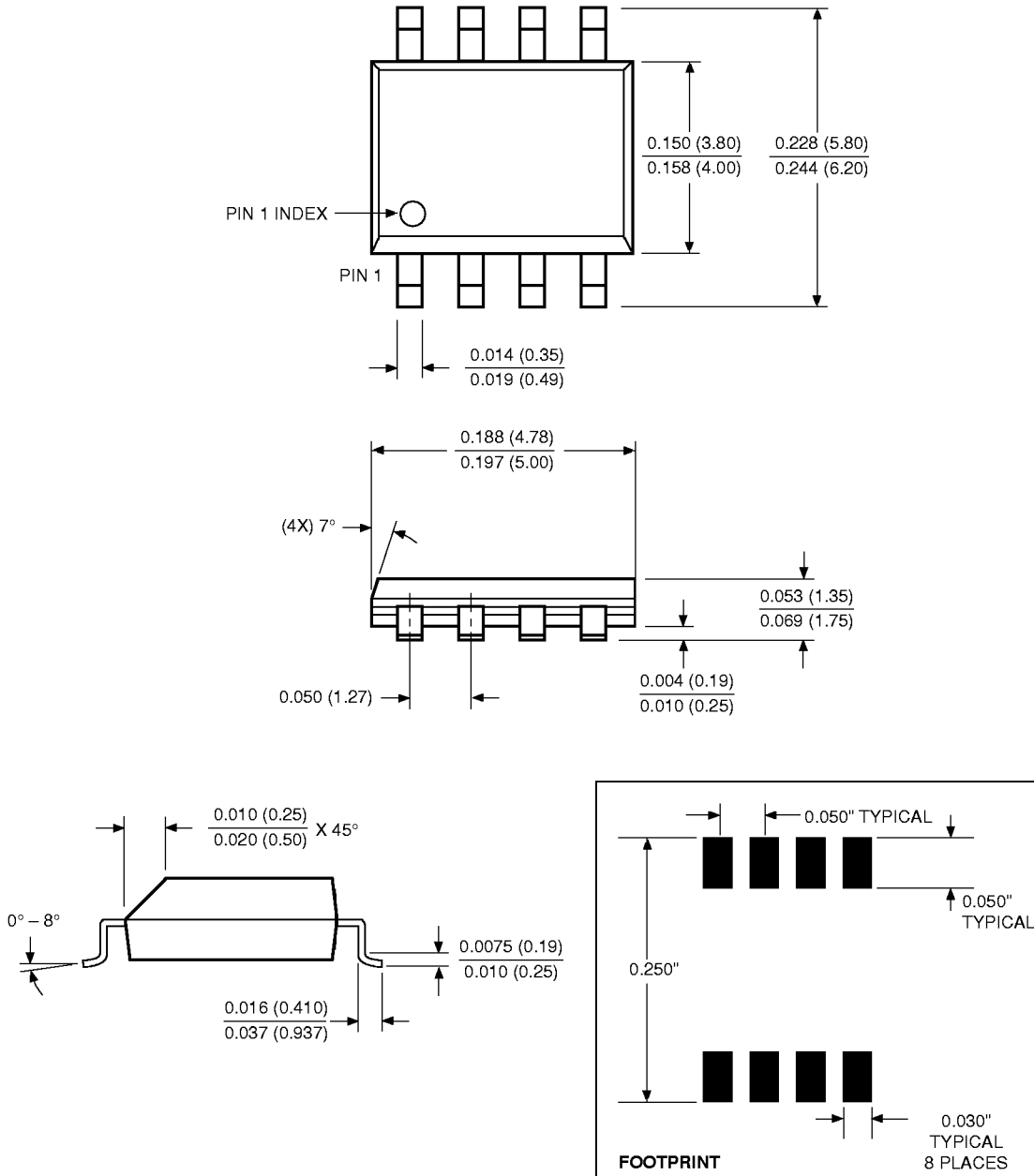

3926 FHD F22.1

# X9511

---

## ORDERING INFORMATION

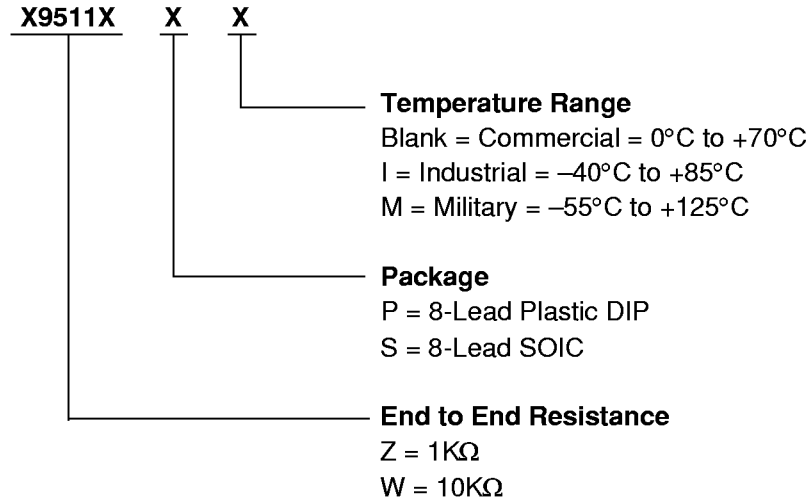

---

### LIMITED WARRANTY

Devices sold by Xicor, Inc. are covered by the warranty and patent indemnification provisions appearing in its Terms of Sale only. Xicor, Inc. makes no warranty, express, statutory, implied, or by description regarding the information set forth herein or regarding the freedom of the described devices from patent infringement. Xicor, Inc. makes no warranty of merchantability or fitness for any purpose. Xicor, Inc. reserves the right to discontinue production and change specifications and prices at any time and without notice.

Xicor, Inc. assumes no responsibility for the use of any circuitry other than circuitry embodied in a Xicor, Inc. product. No other circuits, patents, licenses are implied.

### U.S. PATENTS

Xicor products are covered by one or more of the following U.S. Patents: 4,263,664; 4,274,012; 4,300,212; 4,314,265; 4,326,134; 4,393,481; 4,404,475; 4,450,402; 4,486,769; 4,488,060; 4,520,461; 4,533,846; 4,599,706; 4,617,652; 4,668,932; 4,752,912; 4,829, 482; 4,874, 967; 4,883, 976. Foreign patents and additional patents pending.

### LIFE RELATED POLICY

In situations where semiconductor component failure may endanger life, system designers using this product should design the system with appropriate error detection and correction, redundancy and back-up features to prevent such an occurrence.

Xicor's products are not authorized for use in critical components in life support devices or systems.

1. Life support devices or systems are devices or systems which, (a) are intended for surgical implant into the body, or (b) support or sustain life, and whose failure to perform, when properly used in accordance with instructions for use provided in the labeling, can be reasonably expected to result in a significant injury to the user.
2. A critical component is any component of a life support device or system whose failure to perform can be reasonably expected to cause the failure of the life support device or system, or to affect its safety or effectiveness.