

PANEL CUTOUT

PANEL THICKNESS	(x)
0.75 - 1.25	30.0
1.25 - 2.00	30.4
2.00 - 3.00	30.7

SWITCH FUNCTION	
POS. 1	POS. 2
OFF	ON
NONE	2-1

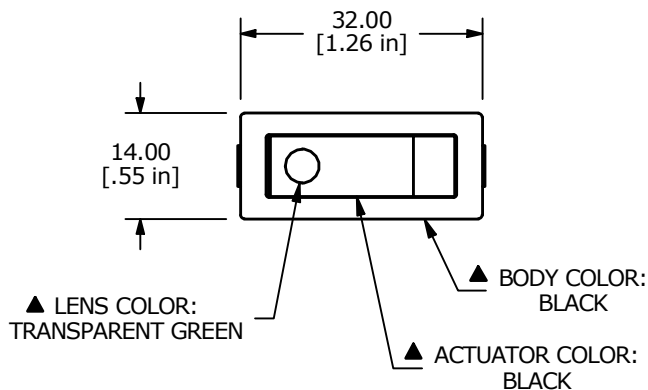
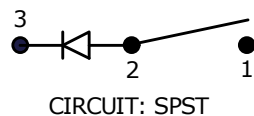

- NOTE:
- DIMENSIONS IN MM [INCH]
 - GENERAL TOLERANCE: X.X = ± 0.4
X.XX = ± 0.25
 - TERMINAL NUMBERS FOR REF ONLY
 - CONTACT MATERIAL: SILVER
 - CONTACT RATINGS:
ANSI/UL 1054 AND CAN/CSA C22.2 NO.55 (E194579):
15A @ 125VAC [cURus]
7.5A @ 250VAC [cURus]
 - CONTACT RESISTANCE: 35mΩ MAX. @ 50VAC INITIAL
 - INSULATION RESISTANCE: 100MΩ MIN. @ 500VDC
 - DIELECTRIC STRENGTH: 1,500VAC FOR 1 MINUTE
 - ELECTRICAL LIFE: 6,000 CYCLES [cURus]
 - OPERATING TEMPERATURE: -20°C to 85°C [cURus]
 - ILLUMINATION VOLTAGE: 12V LED
 - ▲ DENOTES CRITICAL PARAMETER

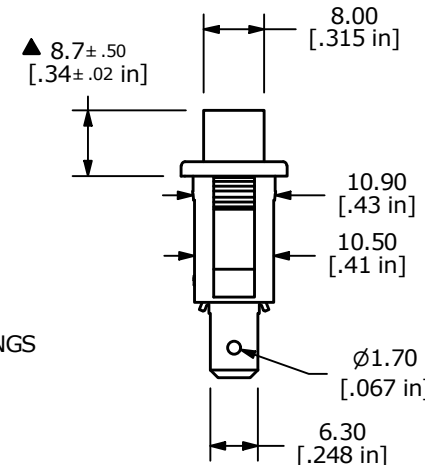
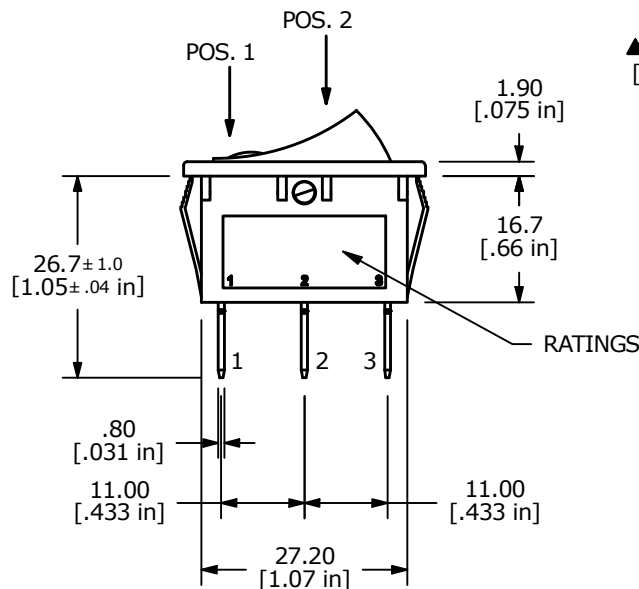

REV	ECO NO	DESCRIPTION	DATE	BY
F	ECO-100575	REMOVE VDE/ENEC RATING AND LOGO	01/04/22	JS



OBJECT ID
000001462

TITLE RB141C1100-234				
SCALE 1:1	DATE 5/3/2011	DR MW	DWG 38-RB141C1100234	REV F