

### **Rochester Electronics Manufactured Components**

Rochester branded components are manufactured using either die/wafers purchased from the original suppliers or Rochester wafers recreated from the original IP. All recreations are done with the approval of the OCM.

Parts are tested using original factory test programs or Rochester developed test solutions to guarantee product meets or exceed the OCM data sheet.

### **Quality Overview**

- ISO-9001
- AS9120 certification
- Qualified Manufacturers List (QML) MIL-PRF-35835
  - Class Q Military
  - Class V Space Level
- Qualified Suppliers List of Distributors (QSLD)
  - Rochester is a critical supplier to DLA and meets all industry and DLA standards.

Rochester Electronics, LLC is committed to supplying products that satisfy customer expectations for quality and are equal to those originally supplied by industry manufacturers.

The original manufacturer's datasheet accompanying this document reflects the performance and specifications of the Rochester manufactured version of this device. Rochester Electronics guarantees the performance of its semiconductor products to the original OEM specifications. 'Typical' values are for reference purposes only. Certain minimum or maximum ratings may be based on product characterization, design, simulation, or sample testing.

### Features

- Unity Gain Bandwidth .....40MHz
- High Slew Rate .....250V/ $\mu$ s
- Low Offset Voltage .....0.8mV
- Fast Settling Time (0.1%) .....90ns
- Power Bandwidth .....4MHz
- Output Voltage Swing (Min) ..... $\pm 10$ V
- Unity Gain Stability
- Monolithic Bipolar Dielectric Isolation Construction

### Description

The HA-2541 is the first unity gain stable monolithic operational amplifier to achieve 40MHz unity gain bandwidth. A major addition to the Harris series of high speed, wideband op amps, the HA-2541 is designed for video and pulse applications requiring stable amplifier response at low closed loop gains.

The uniqueness of the HA-2541 is that its slew rate and bandwidth characteristics are specified at unity gain. Historically, high slew rate, wide bandwidth and unity gain stability have been incompatible features for a monolithic operational amplifier. But features such as 250V/ $\mu$ s slew rate and 40MHz unity gain bandwidth clearly show that this is not the case for the HA-2541. These features, along with 90ns settling time to 0.1%, make this

### Applications

- Pulse and Video Amplifiers
- Wideband Amplifiers
- High Speed Sample-Hold Circuits
- Fast, Precise D/A Converters
- High Speed A/D Input Buffer

product an excellent choice for high speed data acquisition systems.

Packaged in a metal can (TO-8) or 14 pin ceramic DIP, the HA-2541 is pin compatible with the HA-2540 and HA-5190 op amps. The HA-2541-2 is specified over the temperature range of -55 $^{\circ}$ C to +125 $^{\circ}$ C. The HA-2541-5 is specified over the temperature range of 0 $^{\circ}$ C to +75 $^{\circ}$ C. For the military grade product, refer to the HA-2541 military data sheet.

For further application suggestions on the HA-2541, please refer to Application Note 550 (Using the HA-2541), and Application Note 556 (Thermal Safe-Operating-Areas For High Current Operational Amplifiers). Also see Applications' in this data sheet.

### Pinouts

HA1-2541 (CERAMIC DIP)  
TOP VIEW

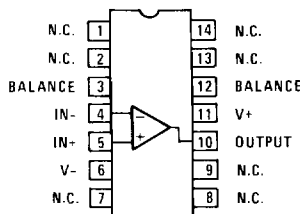

HA2-2541 (TO-8 METAL CAN)  
TOP VIEW

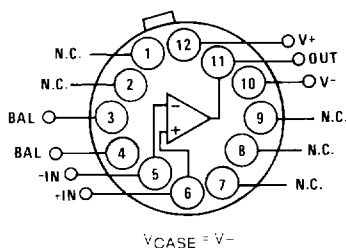

### Schematic

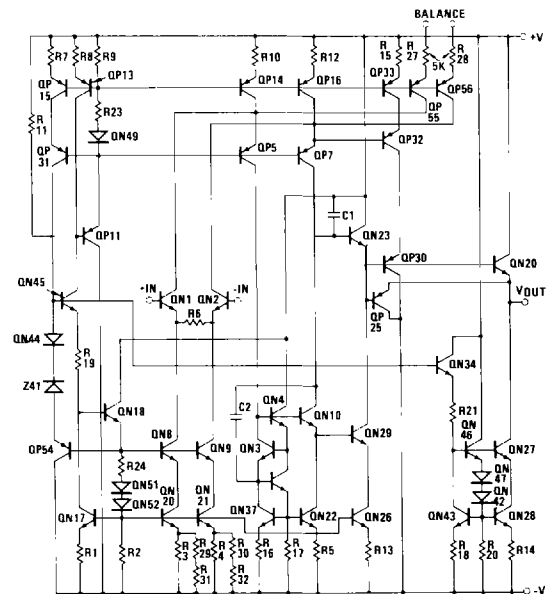

# Specifications HA-2541

HA-2541

### Absolute Maximum Ratings (Note 1)

Voltage Between V+ and V- ..... 35V  
 Differential Input Voltage ..... ±6V  
 Peak Output Current ..... 50mA  
 Continuous Output Current ..... 28mA

### Operating Temperature Range:

HA-2541-2 ..... -55°C ≤ T<sub>A</sub> ≤ +125°C  
 HA-2541-5 ..... 0°C ≤ T<sub>A</sub> ≤ +75°C  
 Storage Temperature Range ..... -65°C ≤ T<sub>A</sub> ≤ +150°C  
 Maximum Junction Temperature (Note 11) ..... +175°C

### Electrical Specifications V<sub>SUPPLY</sub> = ±15 Volts; R<sub>L</sub> = 2kΩ, C<sub>L</sub> ≤ 10pF, Unless Otherwise Specified

PARAMETER	TEMP	HA-2541-2 -55°C to +125°C			HA-2541-5 0°C to +75°C			UNITS
		MIN	TYP	MAX	MIN	TYP	MAX	
<b>INPUT CHARACTERISTICS</b>								
Offset Voltage	+25°C		0.8	2		1	2	mV
	Full			6			6	mV
Average Offset Voltage Drift	Full		9			9		μV/°C
Bias Current	+25°C		11	25		11	25	μA
	Full			30			30	μA
Average Bias Current Drift	Full		85			85		nA/°C
Offset Current	+25°C		1	7		1	7	μA
	Full			9			9	μA
Input Resistance	+25°C		100			100		kΩ
Input Capacitance	+25°C		1			1		pF
Common Mode Range	Full	±10	±11		±10	±11		V
Input Noise Voltage (f = 1kHz, R <sub>g</sub> = 0Ω)	+25°C		10			10		nV/√Hz
Input Noise Current (f = 1kHz, R <sub>g</sub> = 0Ω)	+25°C		4			4		pA/√Hz
<b>TRANSFER CHARACTERISTICS</b>								
Large Signal Voltage Gain (Note 3)	+25°C	10k	16k		10k	16k		V/V
	Full	5k			5k			V/V
Common-Mode Rejection Ratio (Note 5)	Full	70	90		70	90		dB
Minimum Stable Gain	+25°C	1			1			V/V
Unity Gain-Bandwidth (Note 6)	+25°C		40			40		MHz
<b>OUTPUT CHARACTERISTICS</b>								
Output Voltage Swing (Note 4)	Full	±10	±11		±10	±11		V
Output Current (Note 4)	+25°C	±10	±15		±10	±15		mA
Output Resistance	+25°C		2			2		Ω
Full Power Bandwidth (Note 3 & 7)	+25°C	3	4		3	4		MHz
Differential Gain (Note 2)	+25°C		0.1			0.1		%
Differential Phase (Note 2)	+25°C		0.2			0.2		Degree
Harmonic Distortion (Note 10)	+25°C		<0.01			<0.01		%
<b>TRANSIENT RESPONSE (Note 8)</b>								
Rise Time	+25°C		4			4		ns
Overshoot	+25°C		40			40		%
Slew Rate	+25°C	200	250		200	250		V/μs
Settling Time:								
10V Step to 0.1%	+25°C		90			90		ns
10V Step to 0.01%	+25°C		175			175		ns
<b>POWER REQUIREMENTS</b>								
Supply Current	+25°C		29			29		mA
	Full			40			40	mA
Power Supply Rejection Ratio (Note 9)	Full	70	80		70	78		dB

**2**

OP AMPS & COMPARATORS

NOTES:

1. Absolute maximum ratings are limiting values, applied individually, beyond which the serviceability of the circuit may be impaired. Functional operability under any of these conditions is not necessarily implied.
2. Differential Gain and Phase are measured with a 1 Volt differential voltage at 5MHz.
3.  $V_O = \pm 10V$
4.  $R_L = 1k\Omega$
5.  $V_{CM} = \pm 10V$
6.  $V_O = 90mV$ .
7. Full Power Bandwidth guaranteed based on slew rate measurement using  $FPBW = \frac{Slew\ Rate}{2\pi V_{PEAK}}$
8. Refer to Test Circuits section of this data sheet.
9.  $V_{SUPPLY} = \pm 5VDC$  to  $\pm 15VDC$
10.  $V_{IN} = 1V_{RMS}$ ;  $f = 10kHz$ ;  $A_V = 10$
11. This value assumes a no load condition: Maximum power dissipation with load conditions must be designed to maintain the maximum junction temperature below  $+175^\circ C$ . By using Application Note 556 on Safe Operating Area equations, along with the packaging thermal resistances listed in the Die Characteristics section, proper load conditions can be determined. Heat sinking is recommended above  $+75^\circ C$  with suggested models:
  - 14 Lead Ceramic DIP: Thermalloy #6007 or AAVID #5602B ( $\theta_{sa} = 16^\circ C/W$ ).
  - 12 Lead Metal Can (TO-8): Thermalloy #2240A ( $\theta_{sa} = 27^\circ C/W$ ) or #2268B ( $\theta_{sa} = 24^\circ C/W$ )

Test Circuits

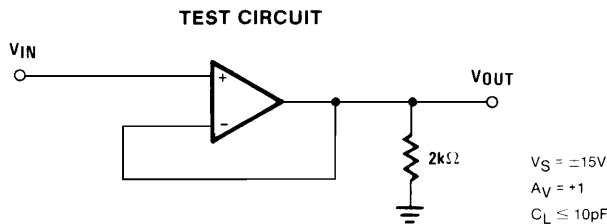

**LARGE SIGNAL RESPONSE**

Vertical Scale (Volts: 5V/Div.)  
Horizontal Scale (Time: 50ns/Div.)

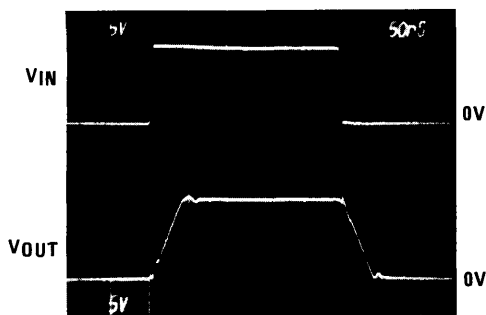

**SMALL SIGNAL RESPONSE**

Vertical Scale (Volts: 100mV/Div.)  
Horizontal Scale (Time: 50ns/Div.)

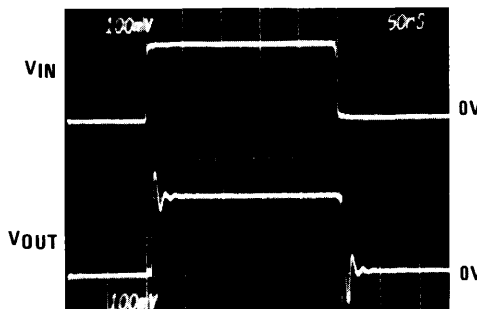

**PROPAGATION DELAY**

Vertical Scale (Volts: 100mV/Div.)  
Horizontal Scale (Time: 5ns/Div.)

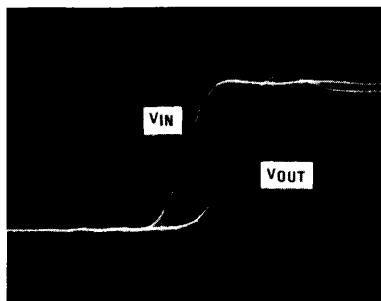

$V_S = \pm 15V$ ,  $R_L = 1k\Omega$   
 $T = +25^\circ C$   
Propagation delay variance is negligible over full temperature range.

Test Circuits (Continued)

SETTLING TIME TEST CIRCUIT

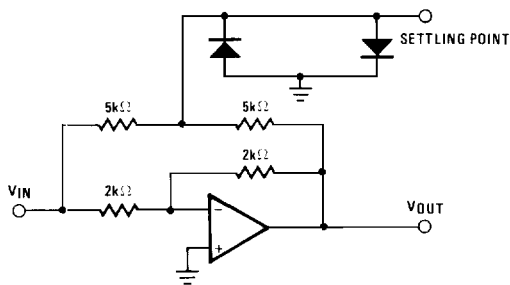

- $A_V = -1$
- Feedback and Summing Resistors Must Be Matched (0.1%)
- HP5082-2810 Clipping Diodes Recommended
- Tektronix P6201 FET Probe Used At Settling Point.

Suggested Offset Voltage Adjustment

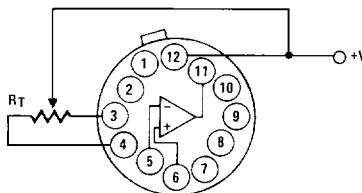

Tested Offset Adjustment Range is  $|V_{OS} + 1mV|$  minimum referred to output. Typical range is  $\pm 15mV$  with  $R_T = 5k\Omega$

Typical Performance Curves

INPUT RESISTANCE vs. FREQUENCY

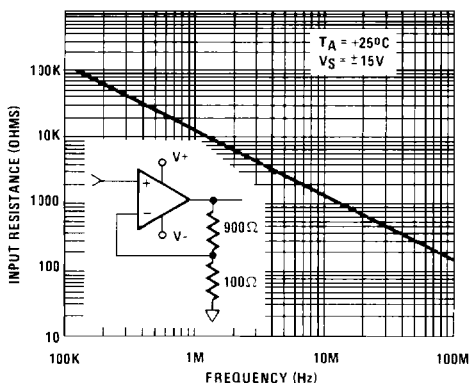

OFFSET VOLTAGE DRIFT WITH TEMPERATURE  
Of 6 Representative Units

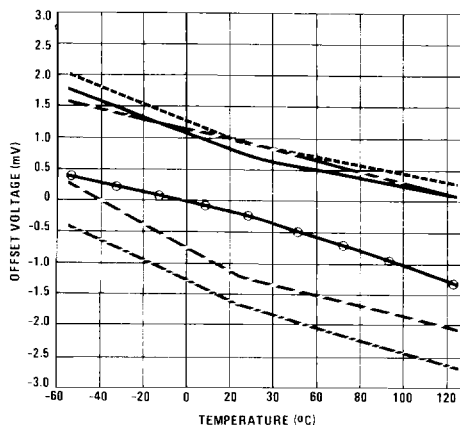

NOISE DENSITY vs. FREQUENCY  
 $T_A = +25^\circ C$

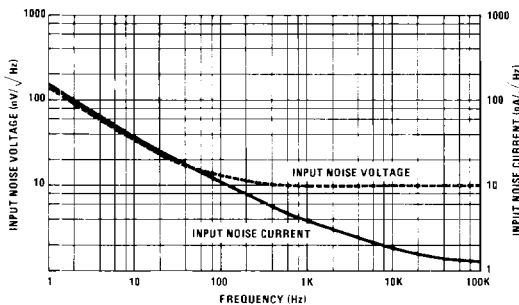

BIAS CURRENT DRIFT WITH TEMPERATURE  
Of 6 Representative Units

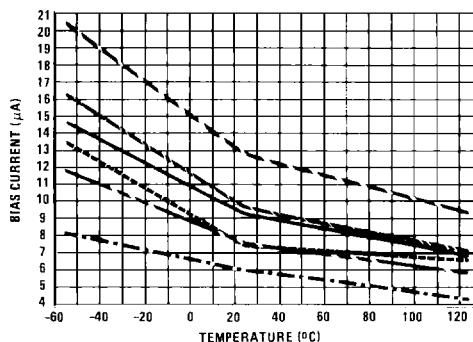

**Typical Performance Curves (Continued)**

**OUTPUT VOLTAGE SWING vs. SUPPLY VOLTAGE**  
At Various Temperatures

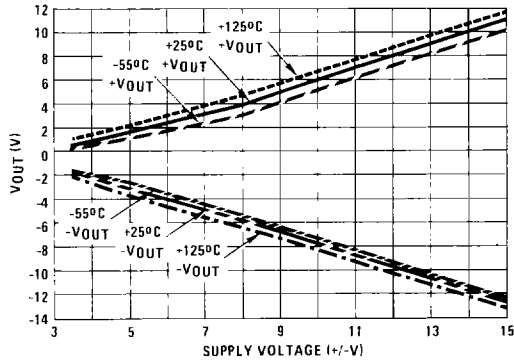

**OUTPUT CURRENT vs. SUPPLY VOLTAGE**  
At Various Temperatures

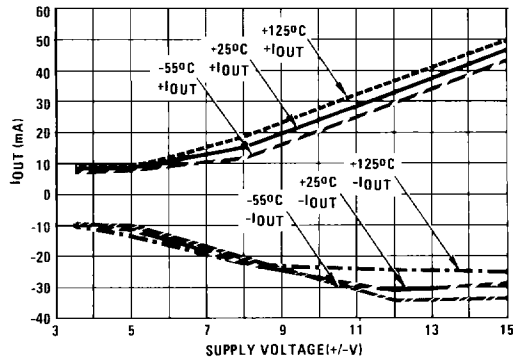

**SUPPLY CURRENT vs. SUPPLY VOLTAGE**  
At Various Temperatures

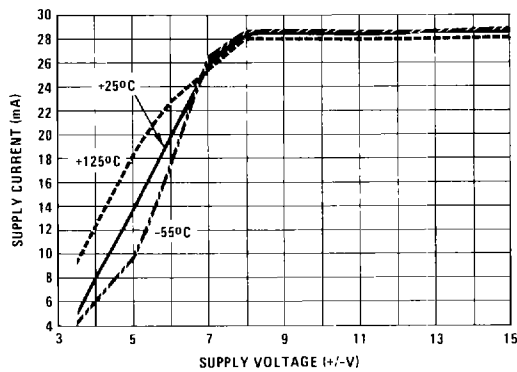

**SLEW RATE vs. SUPPLY VOLTAGE**  
Normalized With V<sub>S</sub> = ±15V at +25°C

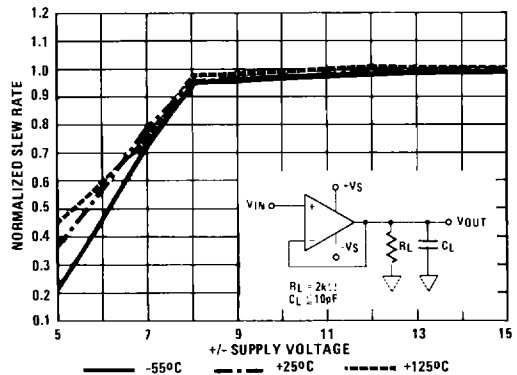

**PSRR vs. SUPPLY VOLTAGE**  
Average Of 3 Lots At Various Temperatures

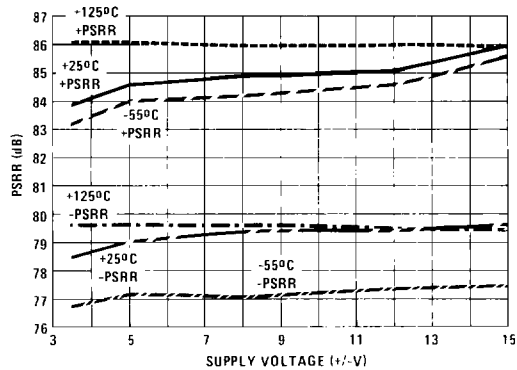

**CMRR vs. SUPPLY VOLTAGE**  
Average of 3 Lots At Various Temperatures

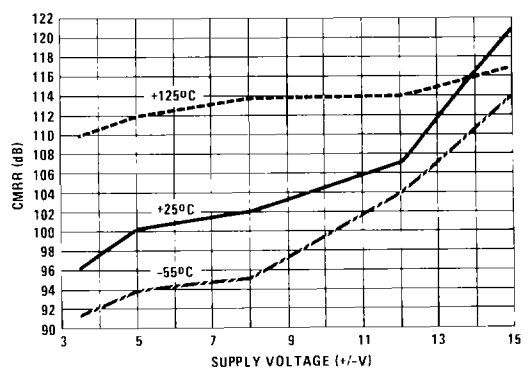

Typical Performance Curves (Continued)

REJECTION RATIOS vs. FREQUENCY

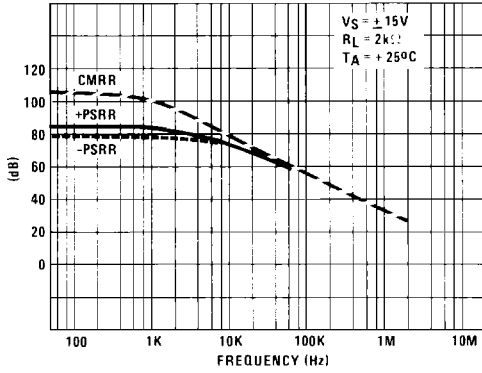

+/- OPEN LOOP GAIN vs. SUPPLY VOLTAGE  
Average of 3 Lots Over Temperature

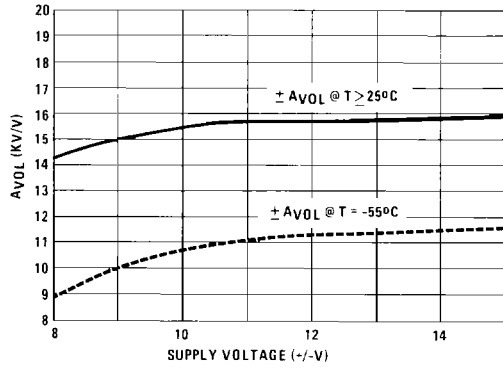

GAIN AND PHASE FREQUENCY RESPONSE

$V_S = \pm 15V, R_L = 1k, C_L \leq 10pF, T_A = +25^\circ C$

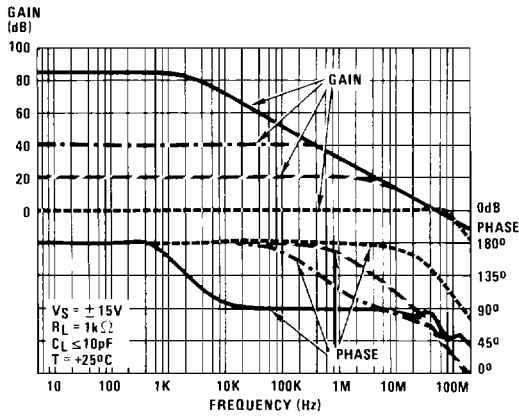

OPEN LOOP —  $A_V = -100$  - - -  $A_V = -10$  ·····  $A_V = -1$

SMALL SIGNAL BANDWIDTH vs. SOURCE RESISTANCE

$V_S = \pm 15V, R_L = 1k\Omega$

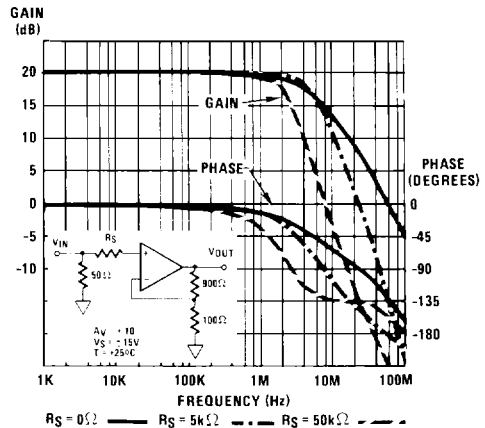

$R_S = 0\Omega$  —  $R_S = 5k\Omega$  - - -  $R_S = 50k\Omega$  ·····

CLOSE LOOP FREQUENCY RESPONSE vs. TEMPERATURE

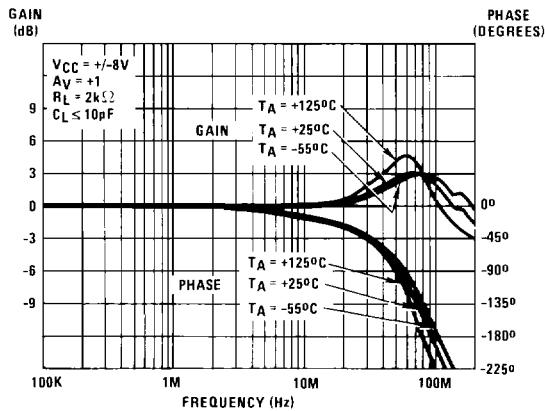

**Applications** (Also See Application Note 550)

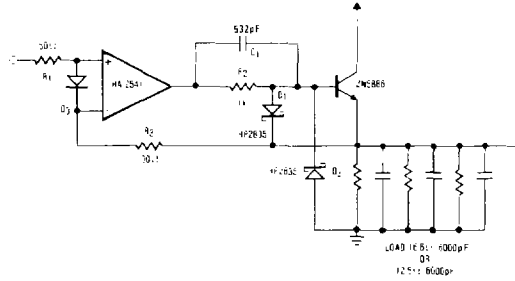

**APPLICATION 1. DRIVING POWER TRANSISTORS TO GAIN ADDITIONAL CURRENT BOOSTING**

**APPLICATION 1**

High power amplifiers and buffers are in use in a wide variety of applications. Many times the "high power" capability is needed to drive large capacitive loads as well as low value resistive loads. In both cases the final driver stage is usually a power transistor of some type, but because of their inherently low gain, several stages of pre-drivers are often required. The HA-2541, with its 10mA output rating, is powerful enough to drive a power transistor without additional stages of current amplification.

This capability is well demonstrated with the high power buffer circuit in Application 1.

The HA-2541 acts as the pre-driver to the output power transistor. Together, they form a unity gain buffer with the ability to drive three 50 ohm coaxial cables in parallel, each with a capacitance of 2000pF. The total combined load is 16.6 ohms and 6000pF capacitance.

**APPLICATION 2**

**Video**

One of the primary uses of the HA-2541 is in the area of video applications. These applications include signal construction, synchronization addition and removal, as well as signal modification. A wide bandwidth device such as the HA-2541 is well suited for use in this class of amplifier. This, however, is a more involved group of applications than ordinary amplifier applications since video signals contain precise DC levels which must be retained.

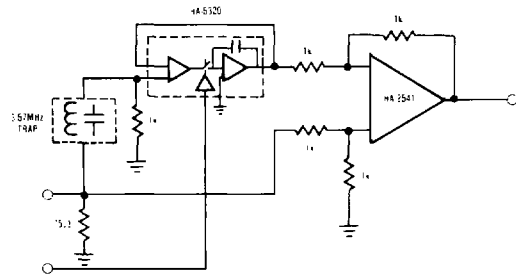

**APPLICATION 2. VIDEO D.C. RESTORER**

**Die Characteristics**

Transistor Count.....	41	
Die Dimensions.....	.89 x .79 x .19 mils (2250 $\mu$ m x 1990 $\mu$ m x 485 $\mu$ m)	
Substrate Potential (Powered Up)* .....	V-	
Process .....	High Frequency Bipolar Dielectric Isolation	
Passivation .....	Silox	
Thermal Constants (°C/W)	$\theta_{ja}$	$\theta_{jc}$
Ceramic DIP	91	35
Metal Can	66	30

\*The substrate may be left floating (Insulating Die Mount) or it may be mounted on a conductor at V- potential.