

**Fast CMOS 3.3V 8-Bit
Buffer/Line Driver**
Features

- Compatible with LCX™ and LVT™ families of products
- Supports 5V Tolerant Mixed Signal Mode Operation
 - Input can be 3V or 5V
 - Output can be 3V or connected to 5V bus
- Advanced Low Power CMOS Operation
- Excellent output drive capability:
Balanced drives (24mA sink and source)
- Low ground bounce outputs
- Hysteresis on all inputs
- Industrial operating temperature range: -40°C to +85°C
- Package (Pb-free & Green available):
 - 20-pin 209-mil wide plastic SSOP (H)

Description

Pericom Semiconductor's PI74LPT244 is an 8-bit buffer/line driver designed for driving high capacitive memory loads. With its balanced-drive characteristics, this high-speed, low power device provides lower ground bounce, transmission line matching of signals, fewer line reflections and lower EMI and RFI effects. This makes it ideal for driving on-board buses and transmission lines.

The PI74LPT244 can be driven from either 3.3V or 5.0V devices allowing this device to be used as a translator in a mixed 3.3/5.0V system.

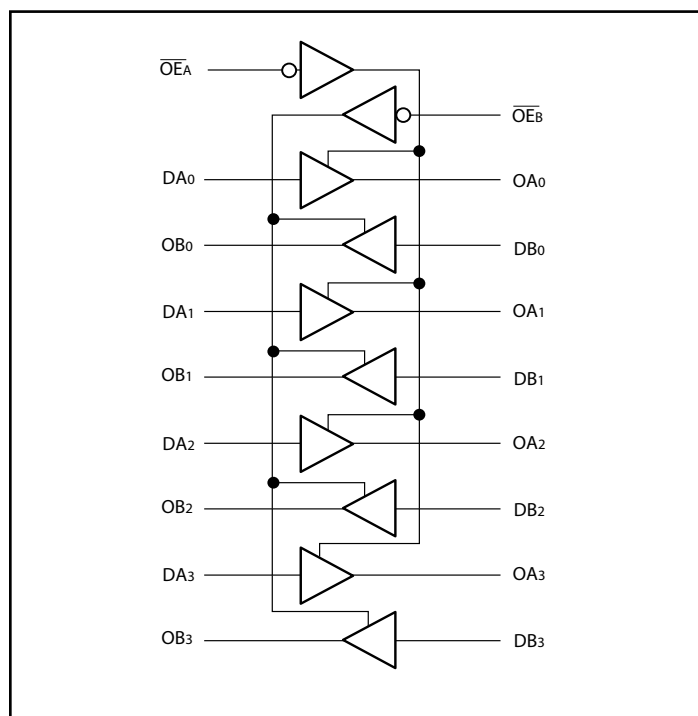
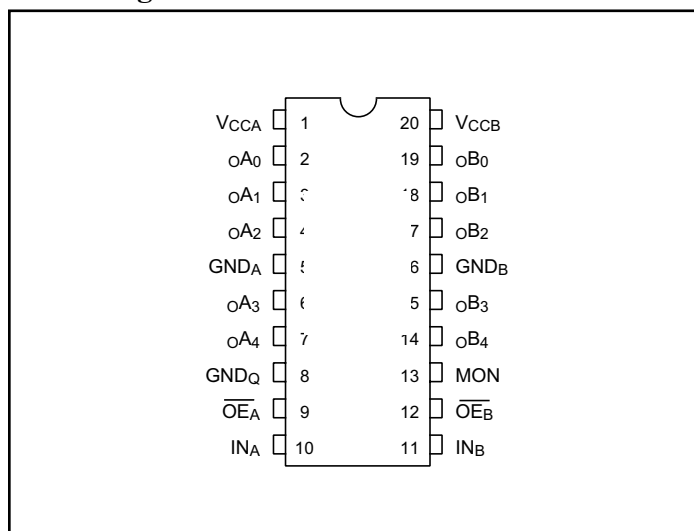
Block Diagram

Pin Configuration

Maximum Ratings

(Above which the useful life may be impaired. For user guidelines, not tested.)

Storage Temperature	-55°C to +125°C
Ambient Temperature with Power Applied	-40°C to +85°C
Supply Voltage to Ground Potential (Inputs & Vcc Only)	-0.5V to +7.0V
Supply Voltage to Ground Potential (Outputs & D/O Only)	-0.5V to +7.0V
DC Input Voltage	-0.5V to +7.0V
DC Output Current.....	120 mA
Power Dissipation	1.0W

Note:

Stresses greater than those listed under MAXIMUM RATINGS may cause permanent damage to the device. This is a stress rating only and functional operation of the device at these or any other conditions above those indicated in the operational sections of this specification is not implied. Exposure to absolute maximum rating conditions for extended periods may affect reliability.

Pin Description

Pin Name	Description
$\overline{OE}_A, \overline{OE}_B$	3-State Output Enable Inputs (Active LOW)
Dxx	Inputs
Oxx	Outputs
GND	Ground
VCC	Power

Truth Table⁽¹⁾

Inputs			Outputs
\overline{OE}_A	\overline{OE}_B	Dxx	Oxx
L	L	L	L
L	L	H	H
H	H	X	Z

Notes:

1. H = High Voltage Level, X = Don't Care,
L = Low Voltage Level, Z = High Impedance

DC Electrical Characteristics (Over the Operating Range, $T_A = -40^{\circ}\text{C}$ to $+85^{\circ}\text{C}$, $V_{CC} = 2.7\text{V}$ to 3.6V)

Parameters	Description	Test Conditions ⁽¹⁾		Min.	Typ ⁽²⁾	Max.	Units
V_{IH}	Input HIGH Voltage (Input pins)	Guaranteed Logic HIGH Level		2.2		5.5	V
	Input HIGH Voltage (I/O pins)			2.0		5.5	
V_{IL}	Input LOW Voltage (Input and I/O pins)	Guaranteed Logic LOW Level		-0.5		0.8	
I_{IH}	Input HIGH Current (Input pins)	$V_{CC} = \text{Max.}$	$V_{IN} = 5.5\text{V}$			± 1	μA
	Input HIGH Current (I/O pins)	$V_{CC} = \text{Max.}$	$V_{IN} = V_{CC}$			± 1	
I_{IL}	Input LOW Current (Input pins)	$V_{CC} = \text{Max.}$	$V_{IN} = \text{GND}$			± 1	
	Input LOW Current (I/O pins)	$V_{CC} = \text{Max.}$	$V_{IN} = \text{GND}$			± 1	
I_{OZH}	High Impedance Output Current	$V_{CC} = \text{Max.}$	$V_{OUT} = 5.5\text{V}$			± 1	
I_{OZL}	(3-State Output pins)	$V_{CC} = \text{Max.}$	$V_{OUT} = \text{GND}$			± 1	
V_{IK}	Clamp Diode Voltage	$V_{CC} = \text{Min.}, I_{IN} = -18\text{ mA}$			-0.7	-1.2	V
I_{ODH}	Output HIGH Current	$V_{CC} = 3.3\text{V}, V_{IN} = V_{IH}$ or $V_{IL}, V_O = 1.5\text{V}$		-36	-60	-110	mA
I_{ODL}	Output LOW Current	$V_{CC} = 3.3\text{V}, V_{IN} = V_{IH}$ or $V_{IL}, V_O = 1.5\text{V}$		50	90	200	
V_{OH}	Output HIGH Voltage	$V_{CC} = \text{Min.}$ $V_{IN} = V_{IH}$ or V_{IL}	$I_{OH} = -0.1\text{ mA}$	$V_{CC} - 0.2$			V
			$I_{OH} = -3\text{ mA}$	2.4	3.0		
		$V_{CC} = 3.0\text{V},$ $V_{IN} = V_{IH}$ or V_{IL}	$I_{OH} = -8\text{ mA}$	2.4 ⁽⁵⁾	3.0		
			$I_{OH} = -24\text{ mA}$	2.0			
V_{OL}	Output LOW Voltage	$V_{CC} = \text{Min.}$ $V_{IN} = V_{IH}$ or V_{IL}	$I_{OL} = 0.1\text{ mA}$			0.2	
			$I_{OL} = 16\text{ mA}$			0.2	0.4
			$I_{OL} = 24\text{ mA}$			0.3	0.5
I_{OS}	Short Circuit Current	$V_{CC} = \text{Max.}, V_{OUT} = \text{GND}$		-60	-85	-240	mA
I_{OFF}	Power Down Disable	$V_{CC} = 0\text{V}, V_{IN}$ or $V_{OUT} \leq 4.5\text{V}$				± 100	μA
V_H	Input Hysteresis				150		mV

Notes:

- For Max. or Min. conditions, use appropriate value specified under Electrical Characteristics for the applicable device type.
- Typical values are at $V_{CC} = 3.3\text{V}$, $+25^{\circ}\text{C}$ ambient and maximum loading.
- Not more than one output should be shorted at one time. Duration of the test should not exceed one second.
- This parameter is guaranteed but not tested.
- $V_{OH} = V_{CC} - 0.6\text{V}$ at rated current.

Capacitance ($T_A = 25^\circ\text{C}$, $f = 1\text{ MHz}$)

Parameters ⁽¹⁾	Description	Test Conditions	Typ	Max.	Units
C_{IN}	Input Capacitance	$V_{IN} = 0V$	4.5	6	pF
C_{OUT}	Output Capacitance	$V_{OUT} = 0V$	5.5	8	

Notes:

1. This parameter is determined by device characterization but is not production tested.

Power Supply Characteristics

Parameters	Description	Test Conditions ⁽¹⁾	Min.	Typ ⁽²⁾	Max.	Units
I_{CC}	Quiescent Power Supply Current	$V_{CC} = \text{Max.}$ $V_{IN} = \text{GND}$ or V_{CC}		0.1	10	μA
ΔI_{CC}	Quiescent Power Supply Current TTL Inputs HIGH	$V_{CC} = \text{Max.}$ $V_{IN} = V_{CC}$ $- 0.6V^{(3)}$			500	μA
I_{CCD}	Dynamic Power Supply ⁽⁴⁾	$V_{CC} = \text{Max.}$, Outputs Open $\overline{OE}_X = \text{GND}$ One Bit Toggling 50% Duty Cycle		50	75	$\mu\text{A}/\text{MHz}$
I_C	Total Power Supply Current ⁽⁶⁾	$V_{CC} = \text{Max.}$, Outputs Open $f_i = 10\text{ MHz}$ 50% Duty Cycle $\overline{OE}_X = \text{GND}$ One Bit Toggling		0.6	2.3	mA
		$V_{CC} = \text{Max.}$, Outputs Open $f_i = 2.5\text{ MHz}$ 50% Duty Cycle $\overline{OE}_X = \text{GND}$ 8 Bits Toggling		2.1	4.7 ⁽⁵⁾	mA

Notes:

1. For Max. or Min. conditions, use appropriate value specified under Electrical Characteristics for the applicable device.
2. Typical values are at $V_{CC} = 3.3V$, $+25^\circ\text{C}$ ambient.
3. Per TTL driven input; all other inputs at V_{CC} or GND .
4. This parameter is not directly testable, but is derived for use in Total Power Supply Calculations.
5. Values for these conditions are examples of the I_{CC} formula. These limits are guaranteed but not tested.
6. $I_C = I_{QUIESCENT} + I_{INPUTS} + I_{DYNAMIC}$
 $I_C = I_{CC} + \Delta I_{CC} D_H N_T + I_{CCD} (f_{CP}/2 + f_i N_i)$
 $I_{CC} = \text{Quiescent Current (} I_{CCL}, I_{CCH} \text{ and } I_{CCZ} \text{)}$
 $\Delta I_{CC} = \text{Power Supply Current for a TTL High Input}$
 $D_H = \text{Duty Cycle for TTL Inputs High}$
 $N_T = \text{Number of TTL Inputs at } D_H$
 $I_{CCD} = \text{Dynamic Current Caused by an Input Transition Pair (HLH or LHL)}$
 $f_{CP} = \text{Clock Frequency for Register Devices (Zero for Non-Register Devices)}$
 $N_{CP} = \text{Number of Clock Inputs at } f_{CP}$
 $f_i = \text{Input Frequency}$
 $N_i = \text{Number of Inputs at } f_i$
 All currents are in milliamps and all frequencies are in megahertz.

Switching Characteristics over Operating Range⁽¹⁾

Parameters	Description	Conditions	LPT244		LPT244A		LPT244C		Units
			Com.		Com.		Com.		
			Min. ⁽²⁾	Max	Min. ⁽²⁾	Max.	Min. ⁽²⁾	Max.	
t _{PLH} t _{PHL}	Propagation Delay D _{xx} to O _{xx}	C _L = 50pF R _L = 500Ω	1.5	6.5	1.5	4.8	1.5	4.1	ns
t _{PZH} t _{PZL}	Output Enable Time O _{Ex} to O _{xx}		1.5	8.0	1.5	6.2	1.5	5.8	
t _{PHZ} t _{PLZ}	Output Disable Time ⁽³⁾ O _{Ex} to O _{xx}		1.5	7.0	1.5	5.6	1.5	5.2	
t _{SK(o)}	Output Skew ⁽⁴⁾			0.5		0.5		0.5	

Notes:

1. Propagation Delays and Enable/Disable times are with V_{cc} = 3.3V ±0.3V, normal range. For V_{cc} = 2.7V, extended range, all Propagation Delays and Enable/Disable times should be degraded by 20%.
2. Minimum limits are guaranteed but not tested on Propagation Delays.
3. This parameter is guaranteed but not production tested.
4. Skew between any two outputs, of the same package, switching in the same direction. This parameter is guaranteed by design.

Packaging Mechanical: 20-pin SSOP (H)

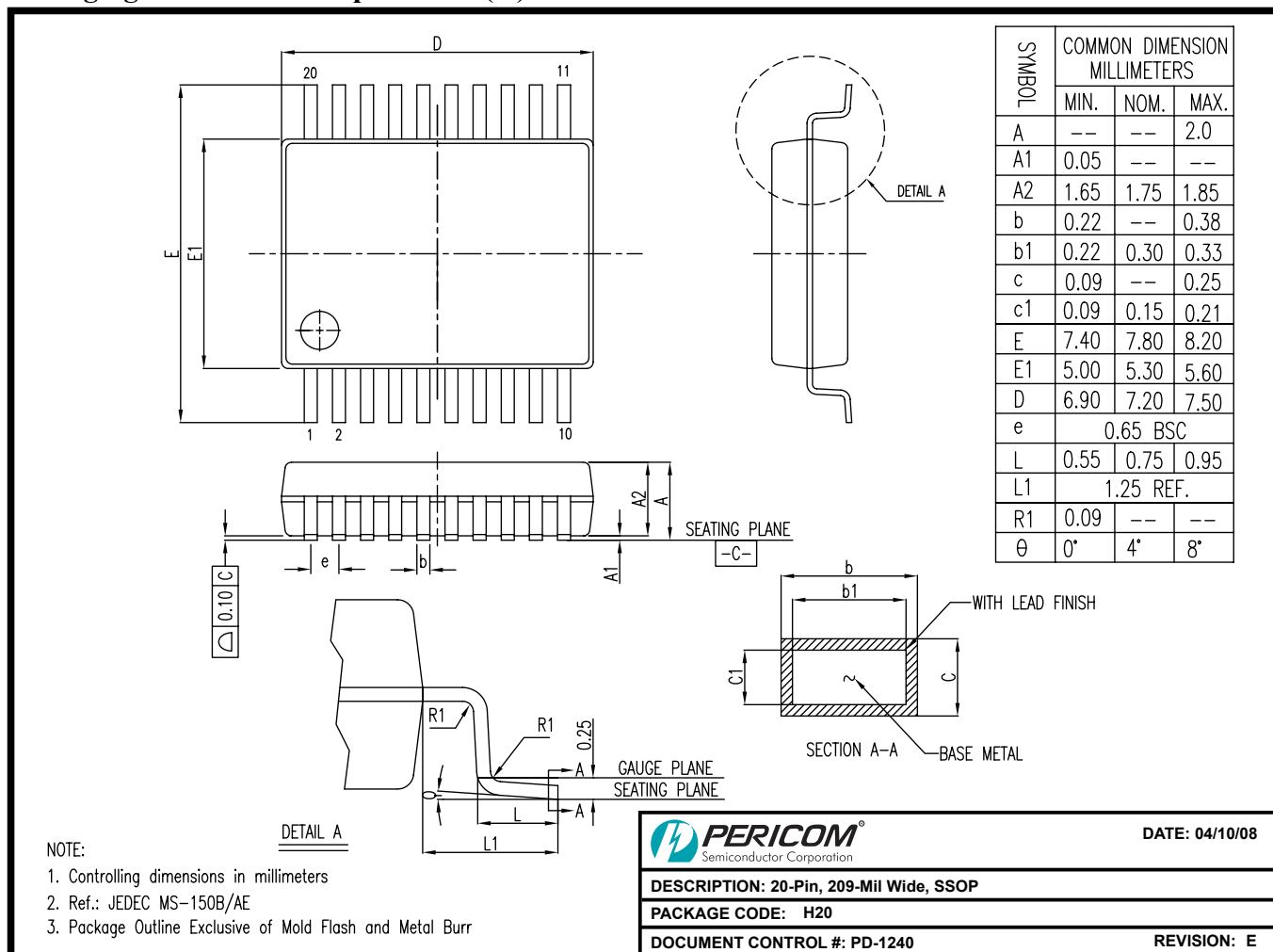

08-0140

Ordering Information

Ordering Code	Package Code	Speed Grade	Description
PI74LPT244AHE	H	A	Pb-free & Green, 20-pin 209-mil wide plastic SSOP

Notes:

- Thermal characteristics can be found on the company web site at www.pericom.com/packaging/
- E = Pb-free and Green
- Adding an X Suffix = Tape/Reel